



## Powerful and Effective Pronunciation Instruction: How Can We Achieve It?

**Pronunciation instruction is still underemphasized in many language programs as well as in teacher-training curricula despite reports of significant improvement from many studies. Three factors may account for this resistance and for the difficulty of making pronunciation an integral part of language teaching: the time obstacle, the methodology obstacle, and the curricular obstacle. I will outline why these obstacles have emerged, and suggest specific solutions to work around them, with the goal of achieving powerful pronunciation practices in the classroom. The approach taken draws on psycholinguistic research about the mechanisms of phonological acquisition in second language (L2) learners (in both in-class and out-of-class learning contexts).**

**S** Spoken language is sound—and sound gives life to grammar and vocabulary. Without the sound (that is, the phonology, or the pronunciation), one cannot bring the rest of language to life.<sup>1</sup> To make the language come alive, then, requires behaviors related to listening, speaking, reading, and writing, and these depend on the three domains of knowledge at the heart of language: phonology, vocabulary (lexis), and structure. These components are part of every language, including sign languages. This description correctly implies that phonology cannot be dissociated from the rest of language and that it is as important a contributor to the four skills as vocabulary and structure.<sup>2</sup> In this article, I will first illustrate more specifically the importance of pronunciation, as well as the contradiction that, despite being widely recognized as important, pronunciation does not receive equal attention in the language curriculum. Today, the reasons for its fringe status in many language curricula are not so much due to the belief that learners will pick it up on their own and that pronunciation

does not need to be taught (although in some circles this belief persists as well); rather, there are multiple reasons leading to this persistent state of affairs. Taking a close look at these reasons, we see that obstacles to pronunciation teaching fall into three main categories:

1. Time (when/why): that is, institutional considerations;
2. Method (how): that is, instructional considerations and methodological uncertainties; and
3. Focus (what): that is, pedagogical priorities.

I will address each of these obstacles and offer specific solutions for how to navigate around them. I will conclude with recommendations and discussion on how to achieve powerful pronunciation instruction.

### **Pronunciation Is Everywhere**

The knowledge system that humans use to process language in their everyday lives is complex. It contains several subdomains, such as knowledge of syntax, vocabulary, phonology, morphology, pragmatics, and sociolinguistics. While these areas are often considered separately for the purpose of linguistic and theoretical investigation, they are all interwoven in the complex task of processing language, including behaviors such as recognizing words, understanding utterances, formulating appropriate answers, talking to a stranger on the phone, finding a way to say something difficult to somebody, or writing a response to an email. It is important to first establish that in this knowledge system, every domain is intertwined, and the influence of phonology goes beyond the behaviors related to speaking or to listening.

Pronunciation and phonology are obviously related to speaking and listening. Pronunciation training improves speaking abilities by helping learners to develop clear speaking skills. Clarity of speaking improves intelligibility and minimizes effort for interlocutors. We know that pronunciation training can also help develop perception abilities, even though experimental evidence is still limited (Linebaugh & Roche, 2015). In turn, clarity of perception also improves listening and understanding of naturally fluent, connected speech—also called running speech (Brown, 2011; Gilbert, 1995). So, owing to its potential to promote clear perception, pronunciation practice can help develop listening comprehension along with word segmentation skills (the ability to recognize separate words in running speech). Speaking and listening are also interconnected. We know that perceptual training can cause second language (L2) learners to improve

both their perception and their production of segmentals and suprasegmentals (Bradlow, Akahane-Yamada, Pisoni, & Tohkura, 1999; Lee & Lyster, 2017; Wang, Jongman, & Sereno, 2003).

Similarly, pronunciation practice is intertwined with both reading and writing, just like orthography is activated while listening to speech (e.g., Ranbom & Connine, 2011; Ziegler, Ferrand, & Montant, 2004). For instance, the pronunciation practices of “chunking” (or segmenting) thought groups by pausing at appropriate places and using reduced speech patterns can (a) facilitate reading aloud and (b) increase reading speed (Van Loon, 2002). Additionally, practicing spelling-sound correspondences develops greater familiarity with orthographic forms, which helps learners in the process of recognizing written words. Pronunciation (and listening) practice also enhances writing. It can reduce spelling mistakes that are due to inaccurate pronunciation (and vice versa, reduce pronunciation errors based on spelling, see Prator, 1971); indirectly, more accurate listening and segmentation skills may also improve writing, for instance, by limiting the omission of function words or reduced forms because they are now better perceived (Brown, 2011; Celce-Murcia, Brinton, & Goodwin, 2010). Growing evidence that training integrating bimodal input (through captioning or subtitling in the target language) directly improves segmentation skills of running speech (Charles & Trenkic, 2015) corroborates these tight links between skill domains and knowledge areas.

To illustrate my point, I offer the following example concerning the important distinction between tense and lax vowels (e.g., *gate* /eɪ/ vs. *get* /ɛ/) in English. As shown in Figure 1, we see that when compiling an English restaurant menu in a non-English-speaking country, the maker of the menu experienced difficulties with this distinction, that is, offering *hot paper* as a pizza topping. While one might think that it would affect the learner only when saying or hearing words containing this distinction, it appears that the confusion also extends to reading and writing.

One explanation for why such confusions affect all skills comes from research on the bilingual mental lexicon (Broersma & Cutler, 2011; Darcy, Daidone, & Kojima, 2013), which suggests that L2 learners often have inaccurate long-term memories (or phonolexical representations) for the words in their L2. While they may clearly know the words in terms of their meaning and usage patterns, the phonological form may be encoded with a lack of precision: That is, learners' phonolexical representations of words may be lacking some detail, or be fuzzy (Cook & Gor, 2015; Darcy, Dekydtspotter, et al., 2012; Trofimovich & John, 2011). An important goal of pronunciation teaching



Figure 1. An example showing that phonology permeates the entire system through speaking, listening, reading, and writing (image courtesy of Ryan Lidster).

should be to help learners develop accurate phonological forms for vocabulary.

To summarize, pronunciation is important and connected with all the skill areas. Ideally it should be taught in connection with all of them. Both teachers and students recognize this, but pronunciation is often not taught for various reasons—a situation that we could call the “pronunciation teaching paradox.”

### The Pronunciation Teaching Paradox

To try to understand the reasons that this paradox occurs, we conducted a survey of teachers’ practices and beliefs about pronunciation in the Intensive English Program at Indiana University (Darcy, Ewert, & Lidster, 2012). Fourteen surveys were completed by instructors. The data revealed a clear pattern concerning what teachers think about pronunciation and the ways to teach it. The teachers as a group believed that pronunciation instruction plays a very important or crucial role in the lives of their students across almost all contexts and situations. This finding is similar to what other studies have reported, in which both teachers and students recognize the importance of pronunciation (Cenoz & Lecumberri, 1999; Levis, 2015; Zielinski & Yates, 2014). However, when asked how much they actually taught pronunciation, and whether or not they were satisfied with how they teach

it, the teachers as a group reported seldom teaching pronunciation, if at all. Only two out of 14 respondents indicated that they were satisfied with their pronunciation teaching. The other teachers indicated a variety of reasons that they were not satisfied. Most of them indicated that pronunciation instruction simply takes far too much time, and that they had problems finding that time. A related issue was that they needed more institutional support to make pronunciation instruction happen. For example, one teacher reported wanting to do it but added that students are not assessed on it anywhere, and so the teacher was unsure whether to spend time on it.

Besides time and the instructional support issues interfering with teaching pronunciation, teachers also felt uncertain about the ways to actually teach pronunciation. The lack of teacher training (Baker, 2014; Foote, Holtby, & Derwing, 2011; Murphy, 2014) compounded by the lack of teaching materials resulted in low confidence. More specifically, teachers' uncertainty was linked to specific pedagogical know-how and methods (what works, why) and to the focus of instruction (the selection and ordering of essential pronunciation features). As evidenced by articles published since the 1970s, this topic has been a recurrent concern (Derwing, Munro, & Wiebe, 1998; Jenner, 1989; Prator, 1971).

An interesting concern voiced by teachers in our survey was the need to be assured that their pronunciation teaching would be effective. For instruction to be perceived as effective implies that it generalizes to daily life outside the classroom. The lack of transfer from classroom to "real life" is an often-cited problem (as far back as Bowen, 1972), and when there is improvement, it is usually quite slow and gradual, not an overnight transformation. Not only might this discourage teachers and learners, but the difficulty of measuring improvement makes it also difficult to assess pronunciation in general (Derwing & Munro, 2015; Trofimovich & Isaacs, 2017).

Concerns about ineffective instruction also appeared in responses when teachers were asked what they thought might be reasons that prevent students from making pronunciation progress. Figure 2 summarizes the answers. More than half of responses (56%) were related to the amount and effectiveness of instruction, practice, and interaction (blue shading). Another 40% of responses (green and yellow shading) "blamed" the learner for having misaligned goals, for not being motivated, for being too old, or for being a native speaker of a particular language. These findings seem to indicate that teachers felt disempowered when it came to pronunciation progress. In sum, pronunciation instruction was quite sporadic, and inconsistent across level, skill, and teacher in the program that we evaluated. So, despite

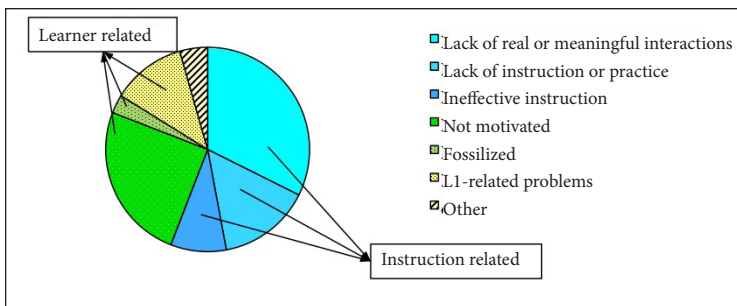

Figure 2. Proportion of responses from each category that teachers gave as possible reasons for preventing improvements in pronunciation.

its small scale, our survey clearly showed that teachers find pronunciation difficult to teach, a situation that might be representative of many similar programs.

The consistent uncertainty voiced by teachers about teaching pronunciation and the overall low satisfaction they feel about how they teach it stands in contrast to their clear perception of its importance—as well as to the actual benefits of explicit pronunciation instruction. Many studies have confirmed global improvement as a result of pronunciation instruction sessions, even when these lasted only a few weeks, and several studies have found that it improved intelligibility and comprehensibility (e.g., Champagne-Muzar, Schneiderman, & Bourdages, 1993; Derwing, Munro, & Wiebe, 1998; Gordon & Darcy, 2016; Ruellot, 2011; Trofimovich, Lightbown, Halter, & Song, 2009; see Lee, Jang, & Plonsky, 2015; Saito, 2012, for meta-analyses; see Thomson & Derwing, 2015, for a narrative review).

### What's Holding Teachers Back?

Numerous potential obstacles to teaching pronunciation exist. While it is of course not the case that every teacher will experience the same difficulties while trying to address pronunciation, it might be useful to examine a variety of concerns to see if patterns can be observed. Once we can identify what is holding teachers back, targeted adjustments can be made that will help bring about changes in teachers' practices or in curriculum development. Some commonly heard concerns or obstacles that prevent teachers from addressing pronunciation in their classes are presented below. When we look at these obstacles, we see that they fall into three big categories.

The first one could be called the “*time* obstacle,” which is about how to find the time to teach pronunciation. The main concerns here include the following:

1. Class time is too short, so there is no time left for pronunciation.
2. Beginning students are too busy learning grammar and vocabulary to concentrate on pronunciation.
3. Students are not assessed in pronunciation, so why should I waste class time on it?

The second obstacle could be called the “*method* obstacle,” which mainly involves instructional and institutional considerations, along with the worry that teaching methods are ineffective or perceived as boring (Baker, 2014). For instance, uncertainties about how exactly to teach pronunciation communicatively, and concerns about providing “authentic” or “standard” input, fall into this category. Concerns include:

4. Intonation is hard to teach.
5. I don’t know how to teach pronunciation.
6. Repeat-after-me and minimal pair drills are boring to teach.
7. I’m not a native speaker of Standard American English.
8. They’re fossilized; they won’t change.
9. It doesn’t work.
10. Students don’t want to work on it.

Finally, the third obstacle could be called the “*focus* obstacle,” which has to do with the problem of finding or deciding what is essential to teach. Concerns, beliefs, and attitudes here include:

11. They’ll pick it up on their own.
12. I don’t know what to do/focus on.
13. My students have so many different L1 backgrounds that I can’t possibly meet their pronunciation needs.

Given these multiple fears and uncertainties regarding pronunciation instruction, the field’s response cannot be simply “Just do it, you’ll be fine.” In what follows, I attempt to suggest solutions to navigate around these three general areas of resistance, including each of the 13 specific concerns about teaching pronunciation.

## General and Specific Obstacles—Suggested Solutions

### *Time*

Time is one of the most common obstacles cited by teachers (see #1 above). Possible reasons for this challenge are lack of training and adequate materials, as well as the fact that pronunciation is often taught separately from other language areas such as grammar or vocabulary. This makes it harder to find extra time among all the other important aspects to cover in language classes, and so “doing pronunciation” often gets short shrift. This challenge of finding time is also crucially related to other concerns falling in this area, such as questioning whether beginning learners should be taught pronunciation (#2), or questioning whether pronunciation is important enough to allot time to (#3), discussed below. One solution to the time problem is to stop looking for extra time and rather address pronunciation together with the other areas of language by giving it regular attention. Teachers can be guided to integrate pronunciation into every lesson (Darcy, Ewert, & Lidster, 2012; Sicola & Darcy, 2015; Zielinski & Yates, 2014). For example, a grammar unit on asking questions with *wh*-words could include specific and explicit microlessons on one or two features, such as the difference in intonation between *wh*-questions and *yes/no* questions. This microlesson can then be reinforced during the rest of the grammar lesson by paying explicit attention to this feature, through explicit feedback and reminders to students to focus on their intonation. An example of integrated exercises for beginners is presented in Appendix A (see also Trofimovich & Gatbonton, 2006, for examples for higher-level students).

Since pronunciation improvement takes time, it is worth seriously considering whether beginners should be taught pronunciation when they are learning grammar and vocabulary (#2). This kind of resistance coincides with the persistent myth that “pronunciation is not for beginning learners” (Zielinski & Yates, 2014), who note that in many programs, pronunciation is an elective class that is reserved for the more advanced levels. Yet pronunciation instruction can be effective and valuable when adapted to learners’ proficiency levels (Darcy, Ewert, & Lidster, 2012), even at the very early stages. In fact, there are very good reasons to start early for both learners and teachers. Starting early will not only get learners further, it will also help teachers become more skilled at teaching pronunciation every day. In this manner, pronunciation instruction becomes a regular routine and an integral, recognized, and necessary part of language learning.

We now turn to another obstacle (#3), which relates to the value of pronunciation in a curriculum. This is a fundamental issue that also connects to time. Aligning priorities and time is one of the solutions

to achieving one's goals and staying on track. When an activity's priority is low, it makes it more difficult to allot time to it. One suggestion is to increase the priority level. When teachers believe that pronunciation is not valued by their program, some might experience this as an obstacle, wondering whether limited class time should be spent on it. Similarly, some students may wonder whether to direct their efforts to pronunciation if they perceive it as a low priority. This perceived lack of value can have different origins. For example, if (a) a program or curriculum does not formulate explicit pronunciation-related student learning outcomes, or (b) there is little formal assessment of pronunciation improvements, or (c) there is a lack of alignment of curriculum goals with assessment measures, the message conveyed to teachers and students is that pronunciation is not a primary concern, and that it does not really matter. If the low priority or misalignment of institutional expectations actually makes it difficult for some teachers to allot time to pronunciation, it might be useful to recall the many reasons that pronunciation should be taught systematically in the classroom:

- Most students want it (Zielinski & Yates, 2014);
- They need it (they do not “pick it up on their own”) (Zielinski, 2012);
- Teaching it works well, especially with careful teaching practices (e.g., Couper, 2006; Derwing, Munro, & Wiebe, 1998); and
- It affects learners' success generally (Derwing, Thomson, & Munro, 2006; Yates, 2011) given the importance of enhanced intelligibility for social and professional interactions, for opportunities on the job market, and for achievement in higher education.

In addition, and perhaps most important of all, the realization that pronunciation practice may have positive effects on other more commonly assessed skills such as reading and writing might ease the time obstacle by changing the view of pronunciation as a low-priority component of language for both students and teachers (see the section “Pronunciation Is Everywhere” and Figure 1).

To sum up, I suggest a three-pronged approach to the time obstacle: Integrate, start early, and increase its priority (e.g., via assessment). The third part of the solution, however, requires collaboration among teachers, learners, and programs. Here, a call to action for teacher-training programs and language institutions is in order. Pronunciation needs to be systematically assessed and evaluated and learners need clear learning objectives related to pronunciation. If both teach-

ers and learners demand it, perhaps institutions will adjust. The message will then be clear to everyone that pronunciation matters.

### ***Method***

The second challenge causing resistance is *how* best to teach pronunciation. What methods work best? Which ways of teaching it lead to the most effective learning and long-lasting improvements?

An important factor in explaining why pronunciation is neglected in many curricula is the widespread insecurity, among native and nonnative teachers alike, about whether methods of pronunciation instruction “work” or not (e.g., concerns #8 or #9 above). This reluctance is understandable; obviously, activities that do not offer any results are not the best possible use of precious class time. However, recent studies suggest that explicit instruction of phonological forms *does* have a significant impact (Thomson & Derwing, 2015). These studies dispel some of the earlier research results (e.g., Purcell & Suter, 1980) that showed more mixed results and cast some doubt on the efficacy of classroom pronunciation instruction. Granted, more research is needed in terms of the realities of the classroom (Gordon, 2014) and the effectiveness of specific methods to enhance intelligibility (Derwing & Munro, 2015). Yet the general consensus of pronunciation research today is that clear and demonstrable results are obtained when teachers have students pay explicit attention to pronunciation features and dedicate class time to meaningful and communicative pronunciation practice.

Insecurity about the effectiveness of teaching pronunciation also depends on the goals of instruction. If the goal is for all learners to achieve a nativelike accent in all situations all of the time, then it is unlikely that even very intensive pronunciation instruction is going to truly work. But if the goal is more attainable,<sup>3</sup> then pronunciation instruction becomes more effective. Ultimately, to dispel teachers’ concerns about effectiveness, we must crack one tough nut: the problem of transfer between classroom practice and spontaneous speech outside of the classroom. As Bowen (1972) notes, very often students who practice a given unit in class do well, but the minute they turn their attention to the message content, the practice effect vanishes. One obvious reason for the lack of transfer can be found in the traditional use of decontextualized pronunciation practice (e.g., rote drills and choral repetition of target words and phrases) that is kept separate from the regular language class and that does not incorporate communicative opportunities using authentic language use relevant to students’ daily lives (Grant, 2014).

A welcome shift in methodology now is directed at the end goal

of promoting transfer, that is, enhancing comfortable intelligibility and comprehensibility of learners' spontaneous speech (Levis, 2005). Current approaches therefore involve communicative and contextualized practice formats (Grant, 2014). Teaching priorities (see the next section, "Focus") also have shifted as a result. And for teachers concerned that instruction involving drills and "repeat-after-me" is boring and ineffective (see concern #6), the good news is that this shift in methods and priorities also brings many different and effective ways to teach pronunciation. And even if change is slow, it is important to mention that pronunciation teaching promotes diversity by recognizing the benefits of a variety of models and standards, both native and nonnative, as speaking models. This offers a welcome chance to provide learners with more varied (and hence, more authentic) input by relying on recordings from both native and nonnative speakers, or from speakers of different English varieties, regardless of the language background of the teacher. Such techniques can lead to more robust phonological learning (Bradlow et al., 1999). Similarly, Murphy (2014) advocates that teachers who are nonnative speakers should not be reluctant to teach pronunciation (see concern #7). They are relevant and attainable models for learners, and they have "insider" expertise from experiencing the process themselves.

So what is the recipe for success in achieving transfer? Integration of pronunciation practice in other skill areas and into every lesson is one component of a possible solution to this problem (Levis & Grant, 2003; Morley, 1991; Scola & Darcy, 2015). The other ingredient is to use a dual-focus approach to teaching pronunciation, which combines a simultaneous focus on form and communicative intent. This dual focus is a necessary component for transfer. Several exemplary frameworks that implement this type of combined approach are proposed in the literature. One is the communicative framework by Celce-Murcia and colleagues (2010), which uses a five-step progression to enable learners to focus on both form and meaning. A second, similar approach is found in the ACCESS framework (Automatization in Communicative Contexts of Essential Speech Segments; see Gatbonton & Segalowitz, 2005; Trofimovich & Gatbonton, 2006). And finally, a third, earlier model is the micro- and macrofocus framework for speech production developed by Morley (1991). What all three frameworks share is the fundamental approach of progressively guiding learners to pay attention first to form, and then progressively to both form and meaning. This is achieved through explicit and targeted practice and by progressively enlarging the focus of attention while using communicative and authentic tasks.

Two additional elements that are important for long-term im-

provement and transfer are working on perception and the use of explicit feedback. In the next section, I explain the psycholinguistic value of such a combined approach. First, I outline what defines effective learning and the psycholinguistic mechanisms of acquisition that make it effective. Then I outline why (and how) working on perception and providing explicit feedback are useful complements to the dual focus on form and meaning.

**What Defines Effective Learning?** Effectiveness of learning relates to how well a treatment/teaching method works in real life, that is, to how what is learned in class actually generalizes to real life. Two aspects characterize effective learning for transfer: Learners need to develop *automaticity* of L2 phonological and phonetic processing, and classroom practice needs to *generalize* to pronunciation behavior in spontaneous speech outside the classroom (Segalowitz & Hulstijn, 2005).

The development of each of these aspects necessary for effective transfer requires different kinds of instruction. To develop automaticity of production, the learner needs opportunities for repetition. Here, activities that are exclusively meaning oriented fail to provide the repetition necessary for automatization, which requires repetition of familiar materials. For generalization of this behavior to spontaneous speech in a variety of contexts, on the other hand, the learner needs meaningful and communicative practice (which should rate high on the scale of authenticity). Here, typical methods that provide the repetition necessary for automaticity to develop (drills, minimal pair repetition, discrimination) fail to promote generalization because of the highly decontextualized nature of the repeated materials (Segalowitz & Hulstijn, 2005). In other words, explicit focus on form in pronunciation instruction is useful (Gordon & Darcy, 2016), but it is not sufficient on its own, as suggested by the three example frameworks mentioned previously. Integration with meaning or with the broader context of the activity also matters. As Park (2000) found, form-focused instruction helped, but learners receiving both form- and meaning-focused instruction demonstrated more improvement than the form-focused group. Pronunciation instruction thus needs to guide learners toward deploying a simultaneous focus on both form (or accuracy) and meaning (or communicative context) at once.

Several strategies suggest themselves in this regard. Privileging activities that are inherently repetitive yet genuinely communicative (Canale & Swain, 1980; Gatbonton & Segalowitz, 1988; Trofimovich & Gatbonton, 2006) has been suggested for promoting the development of comprehensible spontaneous speech. A second strategy to ensure that attention to form is indeed maintained as learners focus more on

meaning is to include activities whose successful completion depends on sufficient control of the skill they target (Loschky & Bley-Vroman, 1993). An example of such an activity, the “Linked Labyrinth,” is presented in Appendix B. This activity is a labyrinth task targeting linking and final consonants, which requires learners to accurately perceive or produce the targeted skill (presence or absence of linking between words) in order to find their way out and receive the secret sentence. This embedded feedback promotes the development of monitoring abilities by training learners to pay attention to accurate pronunciation while focusing on the task at hand. With such practice, ideally, attention to form becomes automatized.

**How to Integrate Perception.** Researchers know that working on perception is important (e.g., Prator & Robinett, 1985; Yule, Hoffman, & Damico, 1987). Early on, textbook authors such as Gilbert (1984) highlighted the close connection between how one hears English and how one speaks English, and consequently she suggested incorporating listening practice into pronunciation instruction. However, working on perception is sometimes perceived as technical and time consuming. Thus, it might help to remember that more accurate perception also might enhance intelligibility and comprehensibility (e.g., Gilbert, 1995; Murphy, 1991; Trofimovich et al., 2009). The major benefit to be expected from perception training and listening practice lies in its potential to develop more targetlike memory representations for the words that are being learned by enabling their phonological form (the sounds that make up a word, its stress pattern, etc.) to be more accurately perceived and memorized. As mentioned previously, research has shown that the way learners memorize the form of L2 words differs from that of native speakers. Fuzzy or imprecise word representations might lead to problems in both word recognition (Broersma & Cutler, 2008; Cutler, 2005) and production (Simonchyk, 2017). Even though research showing specifically *how* pronunciation instruction can enhance phonological representations in memory is not yet available, a few directions for listening practice are nevertheless promising. These include:

1. Contextualized and repeated links to vocabulary items (rather than practicing perception of a difficult contrast using nonsense syllables only, or two unknown words, for instance);
2. Variability (e.g., by presenting a variety of voices, contexts, speech rates, utterance lengths); and
3. Multimodal input (e.g., by using audio and written, or audio and video input modalities).

Specific examples on how to adapt listening practice in these three ways are detailed below. To be effective, practice on perception needs to go beyond isolated “listen and repeat” (Yoshida, 2016), but it does not necessarily require spending hours having students do discrimination tasks. Therefore, perception work should be contextualized by establishing links to the meaning of vocabulary items, and ideally it should provide ample opportunity for repetition and reactivation by presenting items multiple times. Kimppa (2017) presents evidence that repetition is an effective way to enhance the quality of word representations in memory. This kind of work will naturally tie in with teaching listening (Cauldwell, 2013), but it can also be integrated with vocabulary teaching, depending on learners’ proficiency.

The following examples illustrate how this type of perception practice involving repetition might be usefully practiced during a vocabulary lesson (while at the same time enhancing vocabulary retention). In one type of activity, learners practice recognizing the spoken form of targeted words repeatedly, first when the word is spoken in isolation, then in very short sequences, and finally in longer passages. Different tools can be used to implement the activities in these different contexts. For listening in isolation, controlled and self-paced activities such as picture matching or word matching are useful (see Appendix C): In a word-matching task, learners are asked to choose the picture that corresponds to the form they heard. This activity is useful when there are many minimal pairs for a given difficult contrast (such as /r/ and /l/ in English) that are easily pictured. Similarly, a picture-naming task in which the learner is asked to pronounce the name of an object pictured on the screen can be used with relative beginners and can include minimal pairs (such as *rock* and *lock*). When minimal pairs are more difficult to find (e.g., for word stress placement, or when the minimal pairs involve words that are unfamiliar to the learner), the third task, picture matching, asks learners to listen to two items. In this example for practicing the vowel contrast /i/-/ɪ/, one is a real word, for example [stɹɪt] *street*, and the other is a pseudo word, for example \*[stɹɪt]. The learner’s task is to pick which item is the expected pronunciation of the picture (of a street) they see. These activities can be realized with a PowerPoint slide show and audio recordings of words and pseudo words, or short sentences, which the teacher can relatively easily record with a computer.

Listening in longer sentence contexts usually also involves faster speech rates and is well suited for more advanced learners within a listening lesson. Useful activities here include shadowing, for which the learner repeats everything he or she hears like a parrot—while the speech is ongoing, or right after it, if the sentence is short. This activity

is extremely useful because it provides practice in the perception and decoding of running speech, and it can first be practiced for familiar or targeted words and sentences before adding relatively unfamiliar materials. For English, tools such as YouTube or YouGlish (<http://www.YouGlish.com>; see Karatay, 2017, for a review) can be used for this kind of activity.

The second promising direction for implementing perception work is to integrate variability (e.g., speakers of various dialects, genders, ages) into the activities. Again, the site YouGlish provides ample opportunity for repetition of the same word in many different contexts, and it even offers a choice of three different dialects of English. The benefit of integrating variability in the input by using a variety of speaking models and speakers has been verified in phonetic laboratory studies (Bradlow et al., 1999). Similar benefits might be expected to also apply when input is received in a classroom context. A complementary way to integrate variability in perception exercises is to use computer- or web-based programs such as Thomson's (2012) English Accent Coach for practicing discrimination and identification of vowels and consonants of English. This site features recognition and identification games for sounds that are recorded in many different voices.

Finally, multimodal input refers to a combination of written and audio input, as in the provision of captions to accompany a video clip in the target language. Such a combined, rich source of input has the potential to help learners develop their word-recognition skills while listening to speech and to stabilize the form of words in their memory. One of the mechanisms thought to be behind these clear benefits is that providing written input while listening to spoken language makes the input more intelligible to the listener (Levi, Winters, & Pisoni, 2007; Mitterer & McQueen, 2009). Words, which are often quite variable in speech, do not vary (as much) in written form. This ubiquitous variability in spoken language poses well-known challenges to learners attempting to recognize spoken words from spontaneous speech (Connine, Blasko, & Titone, 1993; Floccia, Goslin, Girard, & Konopczynski, 2006; Schmidt, 2009; Tamati, 2014). Because captions reduce the ambiguity about which word is intended, the learner progressively learns to associate the perceived input to the correct word, and little by little, becomes more attuned to how the forms of words change when they are embedded in running speech (Cauldwell, 2013). A relevant recent study by Charles and Trenkic (2015) demonstrated that learners who were exposed to "bimodal input," that is, a video with captions, improved their listening skills (as opposed to a control group). This improvement also generalized to sentences and speakers whom the learners were not familiar with—thus suggesting a long-term ef-

fect on actual word-recognition ability from spontaneous or running speech. Integrating the practice of viewing captioned media, accompanied by shadowing exercises and explicit instruction on how words can change in running speech, appears to be a promising complement for effective pronunciation instruction. However, more research is sorely needed to fully understand the mechanisms involved, and it is still unknown whether all learners are equally able to pay attention to captions and to integrate the two modalities smoothly.

**Feedback.** Finally, the last ingredient for effective pronunciation instruction is the role played by feedback in raising learners' awareness. Studies suggest an important role for corrective feedback, when it is provided together with explicit pronunciation instruction (Kissling, 2013; Saito & Lyster, 2012a, 2012b). Research also suggests that students recognize the importance of oral corrective feedback and seem less anxious about receiving it than their teachers do about providing it (Roothoof & Breeze, 2016; Zhang & Rahimi, 2014).

However, while feedback is more helpful than no feedback, certain *types* of feedback are better suited for pronunciation improvement. It appears that *explicit* feedback is very important. Nonexplicit (or implicit) feedback such as recasts (repeating the learner's message but in targetlike form) can be ambiguous, because—unless specifically informed or forewarned—learners tend to associate such feedback with the *meaning* of their utterance, not its *form* (Lyster, 2004). For example, if a learner produces “on the \*[st.iit]” (attempts *street* with [i]), and the instructor recasts “on the [st.iit], yes,” the learner may interpret this type of feedback as a confirmation check about the meaning or use of the word rather than as a correction about the pronunciation of the vowel. As noted by Lyster (2004), there may be nothing disconfirming in the teacher's recast that causes the learner to notice that her production was incorrect; the learner could even infer from this and other classroom input, assuming the distinction is perceptible to her, that [ɪ] and [i] are interchangeable variants. Much depends on how exactly the feedback is implemented. Nonetheless, as shown in Saito and Lyster (2012a), recasts can be useful for pronunciation targets when the purpose of the feedback is explicit.

Explicit feedback appears especially necessary when pronunciation practice occurs as an integrated component within a broader lesson. Explicitness applies to feedback in much the same way that it applies to instruction (Gordon & Darcy, 2016). For feedback or instruction to be explicit, it has to draw attention to the phonological error, that is, making certain that students recognize that what is being corrected is a form error and not a meaning error. Stating the difficulty or error, delineating precisely the difficulty or the error, and

providing the means of correction are useful ways of making instruction and feedback explicit. For example, the instructor:

1. States the difficulty during instruction: “Look, this is difficult, this is where people make mistakes”;
2. Notes an error when providing feedback: “You’ve made a mistake”;
3. Draws attention to the area of difficulty during instruction: “Look at this specific word and its pronunciation”;
4. Provides specific feedback delineating the error: “You pronounced \_\_\_ like \_\_\_.”; or
5. Provides explicit means of correction as feedback by saying, “This is what you should do.”

One of the reasons providing explicit feedback is effective is that it has the potential to help students develop self-awareness of their pronunciation difficulties, and it helps them recognize when these difficulties occur so that they can learn to self-correct or self-monitor. Higher phonological awareness has been shown to relate to higher comprehensibility ratings (Kennedy & Trofimovich, 2010). The value of explicit feedback and instruction becomes clear when considering evidence that those instructional methods that draw learners’ attention to phonological elements also enhance improvements. Indeed, explicit instruction (Derwing, Munro, & Wiebe, 1998; Gordon & Darcy, 2016), corrective feedback (Hardison, 2004; Saito, 2011; Saito & Lyster, 2012a), and laboratory training studies that provide feedback (Bradlow et al., 1999; Wang et al., 2003) all draw attention to how targeted sounds and other features are pronounced and have been shown to be effective. Therefore, it is likely that explicit feedback works because learners are encouraged to notice how their productions are different from what they should produce. As a result, they can work on targeted adjustments to their speech.

In sum, the ingredients of effective pronunciation instruction entail integrated instruction that contains explicit and communicative activities in which repetition can be incorporated (implementing a dual focus on form and meaning), work on perception, and explicit feedback. Empirical research support for a full understanding of the mechanisms for transfer (automatization and generalization), however, is still missing. Morley’s micro- and macrofocus framework for speech production (1991), the communicative framework by Celce-Murcia et al. (2010), and the ACCESS framework by Gatbonton and Segalowitz (2005) offer options to implement these three aspects (form + meaning, perception, feedback) into teaching.

## ***Focus***

The third challenge that creates resistance is selecting the pronunciation targets that are the most effective. As outlined in the previous section (“Method”), teaching priorities have shifted along with the goal of pronunciation instruction toward achieving comfortable intelligibility (Levis, 2005; Yoshida, 2016). Selecting the appropriate focus for the pronunciation curriculum to achieve this goal can be challenging (see concerns #12 and #13 above).

Research has uncovered a variety of speech dimensions that are known to affect comprehensibility and intelligibility. As outlined in Goodwin (2014), for English these include misplaced or missing prominence, incorrect word stress, inappropriate syllable timing, insufficient differentiation in syllable duration between stressed and unstressed syllables, lack of clearly articulated consonants (both in final position and in stressed syllables), speaking too slowly and/or too fast, too many pauses, and/or pauses that are too long. These speech dimensions fall into three areas: suprasegmentals, segmentals, and fluency. Overall, pronunciation researchers and practitioners argue for a balanced approach that addresses all three areas. It is important to stress that suprasegmental features matter (Anderson-Hsieh, Johnson, & Koehler, 1992), but segmental issues are also important and affect intelligibility (Zielinski, 2006). The best intonation is useless if the foundation it is built on, the segmentals, is unintelligible.

Choosing the right focus for a particular class is not simple. It is useful to have a short list of central features that are recognized as difficult for most learners of a given language and important for intelligibility. This of course implies that the list may vary depending on the target language (e.g., French vs. English). It is also worth noting that the features on this short list are likely to be an issue for most learners of a given target language, regardless of their L1 backgrounds, thus allaying concerns (#13) about how to meet the needs of a class with different first languages. They pertain to the same three areas: suprasegmentals (#1, 2), fluency and rhythm (#3, 4, 5), and segmentals (#6, 7). For English, the following have been recognized as central aspects for a pronunciation curriculum (for instance, see Goodwin, 2014):

1. Word stress, number of syllables;
2. Natural intonation (thought groups) and natural breaks;
3. Connected speech features, linking;
4. Syllable timing and vowel reduction;
5. Pausing and fluency;
6. Final and “important” consonants;
7. Vowel duration.

However, it is also important for the teacher to set priorities and decide which of these features should be targeted. Unfortunately, there is no “gold standard” or “one size fits all,” nor can one really be proposed that will work for all learners everywhere. Thus, the burden of finding out what matters for a specified group of learners falls mainly on the teacher or the program. Note also that phonological proficiency does not typically align with proficiency levels within a program. All learners within a given level might differ in terms of how intelligible their spontaneous speech is, depending on their previous experience in pronunciation but also on a multitude of factors, such as L1 background or the intensity of their interactions in the target language outside of class. Priorities may need to be adjusted, and pronunciation teaching is best if tailored to each learner. Thus, an important aspect of choosing the right focus is to first carefully and systematically evaluate needs by applying an overall diagnosis, based on what the learners can spontaneously produce. For example, if a learner does not produce full sentences yet, working on sentence intonation does not appear useful. Work on perception and listening as part of diagnosis will help complete a full picture of learners’ needs. A fruitful way to help select specific contrasts could be to also consider functional load, which defines how important a particular contrast in the target language is by determining how much weight it carries in distinguishing minimal pairs (Catford, 1987; Derwing & Munro, 2014). For example, the functional load of a contrast such as /n/-/l/ is very high in English (that is, the two sounds have many minimal pairs), as compared to /f/-/θ/ (Munro & Derwing, 2006), and thus would be more likely to warrant emphasis in the curriculum.

### Summary

Lowering or eliminating resistance related to the “when, what, and how” of pronunciation teaching can help us reach our goal of everyday powerful pronunciation instruction. The most important solution that can ease the “time” problem is to integrate pronunciation instruction early in the curriculum. This step will be even more efficient if oral skills are evaluated and assessed regularly. If pronunciation matters on the tests students take, students will also pay attention.

To lower resistance pertaining to “how,” it is critical to make pronunciation instruction fun and real by integrating it into communicative activities. This will help with the transfer problem. There are three major points to keep in mind:

1. Pronunciation elements should be taught explicitly, with explicit feedback to raise learner awareness;

2. Activities should entail repetition of known material while focusing on the aspects of pronunciation and form; they should also incorporate communicative features that help train learners to focus on accuracy while paying attention to the task at hand; and
3. Integrating perception is an effective way to link pronunciation practice to listening skills.

Finally, to reduce the “what” resistance, the most important thing is to help teachers learn how to choose the right focus, which can vary for each new group of learners. This is perhaps the most challenging aspect, logistically and training-wise, because it requires diagnosis and prioritizing. Both are easier to implement if the teacher possesses knowledge about phonology and specific training about pronunciation teaching. Knowing the research about which areas of pronunciation present difficulties for most learners will also help with keeping logistics manageable. As a rule of thumb, it is never wrong to make sure to include elements pertaining to all three areas: segmentals, suprasegmentals, and fluency.

Identifying what is holding teachers back is the first step toward reducing resistance. Learning to reflect and identify the reasons for one’s own individual resistance to teaching pronunciation could be an important step forward in using one’s creativity to move beyond it. This type of self-evaluation, coupled with specific and incremental instructional adjustments, can make a difference between *hoping* to teach pronunciation and *actually* teaching it each and every day.

### **Acknowledgments**

I would like to thank Pilar Prieto, Carmen Perez, Joan C. Mora, as well as audiences at the University of Barcelona and University Pompeu Fabra in Barcelona for feedback on the ideas presented here. In addition, Ryan Lidster, as well as Jae Hyun Ahn, Mamdouh Alhuwaykim, Bihua Chen, Jungyouon Choi, Kenna Daniel, Abadi Eshali, Chi Lung Lee, and Kimberly Wan, from the 2017 English Phonology for Second Language Learning and Teaching course at Indiana University, generously provided ideas and comments about the activities presented in the Appendix.

### **Author**

*Isabelle Darcy is associate professor in the Department of Second Language Studies at Indiana University in Bloomington. She holds a PhD in Linguistics and Cognitive Science from the EHESS in Paris (France) and from the Gutenberg University in Mainz (Germany). She investigates*

*pronunciation instruction, speech perception, and phonological acquisition in the mental lexicon of second language learners.*

## Notes

<sup>1</sup>This article is based on a presentation given as the closing speech of the master's in Theoretical and Applied Linguistics, session 2014-2015, at the Universitat Pompeu Fabra in Barcelona, Spain, on June 5, 2015.

<sup>2</sup><http://languageinstinct.blogspot.com/2006/09/what-is-clt.html>

<sup>3</sup>It is advisable not to set the goals too low:

While it's not practical to set our goal impossibly high, we also can't afford to set it too low. It's not helpful for students to become too complacent and to believe that their pronunciation is fine when, in fact, it may not be easily understood by anyone other than their own teacher and classmates. To be truly intelligible to a wide range of listeners, and not just to willing listeners of their own language background, speakers need to come fairly close to some kind of a recognized standard. (Yoshida, 2016, p. 2)

## References

- Anderson-Hsieh, J., Johnson, R., & Koehler, K. (1992). The relationship between native speaker judgments of nonnative pronunciation and deviance in segmentals, prosody, and syllable structure. *Language Learning*, 42(4), 529-555.
- Baker, A. (2014). Exploring teachers' knowledge of second language pronunciation techniques: Teacher cognitions, observed classroom practices, and student perceptions. *TESOL Quarterly*, 48(1), 136-163. <https://doi:10.1002/tesq.99>
- Bowen, J. D. (1972). Contextualizing pronunciation practice in the ESOL classroom. *TESOL Quarterly*, 6(1), 83-94.
- Bradlow, A., Akahane-Yamada, R., Pisoni, D., & Tohkura, Y. (1999). Training Japanese listeners to identify English /r/ and /l/: Long-term retention of learning in perception and production. *Perception and Psychophysics*, 61, 977-985.
- Broersma, M., & Cutler, A. (2008). Phantom word activation in L2. *System*, 36, 22-34.
- Broersma, M., & Cutler, A. (2011). Competition dynamics of second-language listening. *The Quarterly Journal of Experimental Psychology*, 64, 74-95.
- Brown, S. (2011). *Listening myths: Applying second language research to classroom teaching*. Ann Arbor: University of Michigan Press.
- Canale, M., & Swain, M. (1980). Theoretical bases of communicative approaches to second language teaching and testing. *Applied Linguistics*, 1, 1-47.

- Catford, J. C. (1987). Phonetics and the teaching of pronunciation. A systemic description of English phonology. In J. Morley (Ed.), *Current perspectives on pronunciation: Practices anchored in theory* (pp. 87-100). Alexandria, VA: Teachers of English to Speakers of Other Languages.
- Cauldwell, R. (2013). *Phonology for listening: Teaching the stream of speech*. Birmingham, England: Speech in Action.
- Celce-Murcia, M., Brinton, D. M., Goodwin, J. M. (with Griner, B.). (2010). *Teaching pronunciation: A course book and reference guide* (2nd ed.). New York, NY: Cambridge University Press.
- Cenoz, J., & Lecumberri, M. L. G. (1999). The acquisition of English pronunciation: Learners' views. *International Journal of Applied Linguistics*, 9, 3-15. doi.org/10.1111/j.1473-4192.1999.tb00157.x
- Champagne-Muzar, C., Schneiderman, E., & Bourdages, J. (1993). Second language accent: The role of pedagogical environment. *International Review of Applied Linguistics in Language Teaching*, 31, 143-160.
- Charles, T., & Trenkic, D. (2015). Speech segmentation in a second language: The role of bi-modal input. In Y. Gambier, A. Caimi, & C. Mariotti (Eds.), *Subtitles and language learning* (pp. 173-197). Bern, Switzerland: Peter Lang.
- Connine, C. M., Blasko, D. G., & Titone, D. (1993). Do the beginnings of spoken words have a special status in auditory word recognition? *Journal of Memory and Language*, 32, 193-210. doi.org/10.1006/jmla.1993.1011
- Cook, S. V., & Gor, K. (2015). Lexical access in L2: Representational deficit or processing constraint? *The Mental Lexicon*, 10, 247-270. doi.org/10.1075/ml.10.2.04coo
- Couper, G. (2006). The short and long-term effects of pronunciation instruction. *Prospect*, 21, 46-66.
- Cutler, A. (2005). The lexical statistics of word recognition problems caused by L2 phonetic confusion. In *Proceedings of Interspeech 2005* (pp. 413-416), 9th European Conference on Speech Communication and Technology, Lisbon, Portugal, September 4-8, 2005. Retrieved from ISCA Archive: <http://www.mpi.nl/publications/escidoc-57393>
- Darcy, I., Daidone, D., & Kojima, C. (2013). Asymmetric lexical access and fuzzy lexical representations in second language learners. *The Mental Lexicon*, 8, 372-420.
- Darcy, I., Dekydtspotter, L., Sprouse, R. A., Glover, J., Kaden, C., McGuire, M., & Scott, J. H. (2012). Direct mapping of acoustics to phonology: On the lexical encoding of front rounded vowels in

- L1 English–L2 French acquisition. *Second Language Research*, 28, 5-40.
- Darcy, I., Ewert, D., Chen, X., Wang, L., & Lidster, R. (2011, September). Bringing pronunciation instruction back into the classroom. Paper presented at the 3rd Pronunciation in Second Language Learning and Teaching Conference, Ames, IA.
- Darcy, I., Ewert, D., & Lidster, R. (2012). Bringing pronunciation instruction back into the classroom: An ESL teachers' pronunciation "toolbox." In J. Levis & K. LeVelle (Eds.), *Proceedings of the 3rd Pronunciation in Second Language Learning and Teaching Conference* (pp. 93-108). Ames: Iowa State University.
- Derwing, T., & Munro, M. J. (2014). Once you have been speaking a second language for years, it's too late to change your pronunciation. In L. Grant (Ed.), *Pronunciation myths: Applying second language research to classroom teaching* (pp. 34-55). Ann Arbor: University of Michigan Press.
- Derwing, T. M., & Munro, M. J. (2015). *Pronunciation fundamentals: Evidence-based perspectives for L2 teaching and research*. Amsterdam, The Netherlands: Benjamins.
- Derwing, T. M., Munro, M. J., & Wiebe, G. (1998). Evidence in favor of a broad framework for pronunciation instruction. *Language Learning*, 48, 393-410.
- Derwing, T. M., Thomson, R. I., & Munro, M. J. (2006). English pronunciation and fluency development in Mandarin and Slavic speakers. *System*, 34, 183-193. <http://dx.doi.org/10.1016/j.system.2006.01.005>
- Floccia, C., Goslin, J., Girard, F., & Konopczynski, G. (2006). Does a regional accent perturb speech processing? *Journal of Experimental Psychology: Human Perception and Performance*, 32, 1276-1293.
- Foote, J. A., Holtby, A. K., & Derwing, T. M. (2011). Survey of the teaching of pronunciation in adult ESL programs in Canada, 2010. *TESL Canada Journal*, 20, 1-22.
- Gatbonton, E., & Segalowitz, N. (1988). Creative automatization: Principles for promoting fluency within a communicative framework. *TESOL Quarterly*, 22(3), 473-492.
- Gatbonton, E., & Segalowitz, N. (2005). Rethinking communicative language teaching: A focus on access to fluency. *Canadian Modern Language Review/La revue canadienne des langues vivantes* 61, 325-353. doi:10.3138/cmlr.61.3.325
- Gilbert, J. (1984). *Clear speech*. New York, NY: Cambridge University Press.

- Gilbert, J. (1995). Pronunciation practice as an aid to listening comprehension. In D. Mendelsohn & J. Rubin (Eds.), *A guide to the teaching of second language listening* (pp. 97-112). San Diego, CA: Dominic Press.
- Goodwin, J. (2014). Teaching pronunciation. In M. Celce-Murcia, D. M. Brinton, & M. A. Snow (Eds.), *Teaching English as a second or foreign language* (4th ed., pp. 136-152). Boston, MA: National Geographic Learning/Heinle Cengage Learning.
- Gordon, J. (2014). *Teaching and learning L2 pronunciation: A closer look at classroom and extra-classroom factors in the development of comprehensibility in ESL learners* (Unpublished doctoral dissertation). Indiana University, Bloomington, IN.
- Gordon, J., & Darcy, I. (2016). The development of comprehensible speech in L2 learners: A classroom study on the effects of short-term pronunciation instruction. *Journal of Second Language Pronunciation*, 2, 56-92. <https://doi.org/10.1075/jslp.2.1.03gor>
- Grant, L. (2014). Prologue to the myths: What teachers need to know. In L. Grant (Ed.), *Pronunciation myths: Applying second language research to classroom teaching* (pp. 1-33). Ann Arbor: University of Michigan Press.
- Hardison, D. M. (2004). Generalization of computer-assisted prosody training: Quantitative and qualitative findings. *Language Learning and Technology*, 8, 34-52.
- Jenner, B. (1989). Teaching pronunciation: The common core. *Speak Out!*, 4, 2-4.
- Karatay, Y. (2017). Review of YouGlish.com [website]. In M. O'Brien & J. Levis (Eds.), *Proceedings of the 8th Pronunciation in Second Language Learning and Teaching Conference* (pp. 254-259). Ames: Iowa State University.
- Kennedy, S., & Trofimovich, P. (2010). Language awareness and second language pronunciation: A classroom study. *Language Awareness*, 19, 171-185.
- Kimppa, L. (2017). *Rapid formation and activation of lexical memory traces in human neocortex* (Unpublished doctoral dissertation). University of Helsinki, Helsinki, Finland.
- Kissling, E. M. (2013). Teaching pronunciation: Is explicit phonetics instruction beneficial for FL learners? *The Modern Language Journal*, 97, 720-744.
- Lee, J., Jang, J., & Plonsky, L. (2015). The effectiveness of second language pronunciation instruction: A meta-analysis. *Applied Linguistics*, 36, 345-366.
- Lee, A. H., & Lyster, R. (2017). Can corrective feedback on second

- language speech perception errors affect production accuracy? *Applied Psycholinguistics*, 38, 371-393.
- Levi, S. V., Winters, S. J., & Pisoni, D. B. (2007). Speaker-independent factors affecting the perception of foreign accent in a second language. *The Journal of the Acoustical Society of America*, 121, 2327-2338.
- Levis, J. (2005). Changing contexts and shifting paradigms in pronunciation teaching. *TESOL Quarterly*, 39(3), 367-377. doi.org/10.2307/3588485
- Levis, J. (2015). Learners' views of social issues in pronunciation learning. *Journal of Academic Language and Learning*, 9, A42-A55.
- Levis, J., & Grant, L. (2003). Integrating pronunciation into ESL/EFL classrooms. *TESOL Journal*, 12, 13-19.
- Linebaugh, G., & Roche, T. (2015). Evidence that L2 production training can enhance perception. *Journal of Academic Language and Learning*, 9, A1-A17.
- Loschky, L., & Bley-Vroman, R. (1993). Grammar and task-based methodology. In G. Crookes & S. Gass (Eds.), *Tasks and language learning: Integrating theory and practice* (pp. 123-167). Clevedon, England: Multilingual Matters.
- Lyster, R. (2004). Differential effects of prompts and recasts in form-focused instruction. *Studies in Second Language Acquisition*, 26, 399-432. doi.org/10.1017/S0272263104263021
- Mitterer, H., & McQueen, J. M. (2009). Foreign subtitles help but native-language subtitles harm foreign speech perception. *PLOS ONE*, 4(11), e7785. doi.org/10.1371/journal.pone.0007785
- Morley, J. (1991). The pronunciation component in teaching English to speakers of other languages. *TESOL Quarterly*, 25(3), 114-153.
- Munro, M. J., & Derwing, T. M. (2006). The functional load principle in ESL pronunciation instruction: An exploratory study. *System*, 34, 520-531. http://dx.doi.org/10.1016/j.system.2006.09.004
- Murphy, J. M. (1991). Oral communication in TESOL: Integrating speaking, listening, and pronunciation. *TESOL Quarterly*, 25(1), 51-75
- Murphy, J. M. (2014). Teacher training programs provide adequate preparation in how to teach pronunciation. In L. Grant (Ed.), *Pronunciation myths: Applying second language research to classroom teaching* (pp. 188-224). Ann Arbor: University of Michigan Press.
- Park, J. K. (2000). *The effects of forms and meaning-focused instruction on ESL learners' phonological acquisition* (Doctoral dissertation, University of Pennsylvania). Retrieved from http://repository.upenn.edu/dissertations/AAI9976464

- Prator, C. H. (1971). Phonetics vs. phonemics in the ESL classroom: When is allophonic accuracy important? *TESOL Quarterly*, 5(1), 61-72.
- Prator, C. H., & Robinett, B. W. (1985). *Manual of American English pronunciation* (4th ed.). New York, NY: Holt, Rinehart & Winston.
- Purcell, E. T., & Suter, R. W. (1980). Predictors of pronunciation accuracy: A reexamination. *Language Learning*, 30, 271-287.
- Ranbom, L. J., & Connine, C. M. (2011). Silent letters are activated in spoken word recognition. *Language and Cognitive Processes*, 26, 236-261. doi.org/10.1080/01690965.2010.486578
- Roothoof, H., & Breeze, R. (2016). A comparison of EFL teachers' and students' attitudes to oral corrective feedback. *Language Awareness*, 25, 318-335. doi.org/10.1080/09658416.2016.1235580
- Ruellot, V. (2011). Computer-assisted pronunciation learning of French /u/ and /y/ at the intermediate level. In J. Levis & K. LeVelle (Eds.), *Proceedings of the 2nd Pronunciation in Second Language Learning and Teaching Conference* (pp. 199-213). Ames: Iowa State University.
- Saito, K. (2011). Examining the role of explicit phonetic instruction in native-like and comprehensible pronunciation development: An instructed SLA approach to L2 phonology. *Language Awareness*, 20, 45-59. doi.org/10.1080/09658416.2010.540326
- Saito, K. (2012). Effects of instruction on L2 pronunciation development: A synthesis of 15 quasi-experimental intervention studies. *TESOL Quarterly*, 46(4), 842-854. doi.org/10.1002/tesq.67
- Saito, K., & Lyster, R. (2012a). Effects of form-focused instruction and corrective feedback on L2 pronunciation development of /ɪ/ by Japanese learners of English. *Language Learning*, 62, 595-633.
- Saito, K., & Lyster, R. (2012b). Investigating the pedagogical potential of recasts for L2 vowel acquisition. *TESOL Quarterly*, 46(2), 387-398.
- Schmidt, L. B. (2009). The effect of dialect familiarity via a study abroad experience on L2 comprehension of Spanish. In E. K. Brown, J. Collentine, M. García, B. Lafford, & F. Marcos Marín (Eds.), *Selected proceedings of the 11th Hispanic Linguistics Symposium* (pp. 143-154). Somerville, MA: Cascadilla Proceedings Project.
- Segalowitz, N., & Hulstijn, J. (2005). Automaticity in bilingualism and second language learning. In J. F. Kroll & A. De Groot (Eds.), *Handbook of bilingualism: Psycholinguistic approaches* (pp. 371-388). New York, NY: Oxford University Press.

- Sicola, L., & Darcy, I. (2015). Integrating pronunciation into the language classroom. In M. Reed & J. Levis (Eds.), *Handbook of English pronunciation* (pp. 467-483). Malden, MA: Wiley.
- Simonchyk, A. (2017). *The relationships between perception, production, lexical encoding and orthography in the acquisition of palatalization in L2 Russian* (Unpublished doctoral dissertation). Indiana University, Bloomington, IN.
- Tamati, T. N. (2014). *Individual and group differences in the perception of regional dialect variation in a second language* (Unpublished doctoral dissertation). Indiana University, Bloomington, IN.
- Thomson, R. I. (2012). English Accent Coach (Version 2.3) [Web-based software]. Retrieved from <http://www.englishaccentcoach.com/>
- Thomson, R. I., & Derwing, T. M. (2015). The effectiveness of L2 pronunciation instruction: A narrative review. *Applied Linguistics*, 36, 326-344. doi.org/10.1093/applin/amu076
- Trofimovich, P., & Gatbonton, E. (2006). Repetition and focus on form in processing L2 Spanish words: Implications for pronunciation instruction. *The Modern Language Journal*, 90, 519-535.
- Trofimovich, P., & Isaacs, T. (2017). Second language pronunciation assessment: A look at the present and the future. In T. Isaacs & P. Trofimovich (Eds.), *Second language pronunciation assessment: Interdisciplinary perspectives* (pp. 259-271). Bristol, England: Multilingual Matters.
- Trofimovich, P., & John, P. (2011). Chapter 5. When three equals tree. In P. Trofimovich & K. McDonough (Eds.), *Applying priming methods to L2 learning, teaching and research: Insights from psycholinguistics* (pp. 105-129). Philadelphia, PA: Benjamins.
- Trofimovich, P., Lightbown, P. M., Halter, R. H., & Song, H. (2009). Comprehension-based practice. *Studies in Second Language Acquisition*, 31, 609-639. doi.org/10.1017/S0272263109990040
- Van Loon, J. (2002). Improving pronunciation of adult ESL students. *TESOL Canada Journal*, 20, 83-88.
- Wang, W., Jongman, A., & Sereno, J. A. (2003). Acoustic and perceptual evaluations of Mandarin tone productions before and after perceptual training. *Journal of the Acoustical Society of America*, 113, 1033-1043.
- Yates, L. (2011). Language, interaction and social inclusion in early settlement. *International Journal of Bilingual Education and Bilingualism*, 14, 457-471.
- Yoshida, M. T. (2016). *Beyond repeat after me: Teaching pronunciation to English learners*. Alexandria, VA: Teachers of English to Speakers of Other Languages.

- Yule, G., Hoffman, P., & Damico, J. (1987). Paying attention to pronunciation: The role of self-monitoring in perception. *TESOL Quarterly*, 21(4), 765-768. doi.org/10.2307/3586994
- Zhang, L. J., & Rahimi, M. (2014). EFL learners' anxiety level and their beliefs about corrective feedback in oral communication classes. *System*, 42, 429-439. <http://dx.doi.org/10.1016/j.system.2014.01.012>
- Ziegler, J., Ferrand, L., & Montant, M. (2004). Visual phonology: The effects of orthographic consistency on different auditory word recognition tasks. *Memory and Cognition*, 32, 732-741.
- Zielinski, B. (2006). The intelligibility cocktail: An interaction between speaker and listener ingredients. *Prospect*, 21, 22-45.
- Zielinski, B. (2012). The social impact of pronunciation difficulties: Confidence and willingness to speak. In J. Levis & K. LeVelle (Eds.), *Proceedings of the 3rd Pronunciation in Second Language Learning and Teaching Conference* (pp. 18-26). Ames: Iowa State University.
- Zielinski, B., & Yates, L. (2014). Pronunciation instruction is not appropriate for beginning-level learners. In L. Grant (Ed.), *Pronunciation myths: Applying second language research to classroom teaching* (pp. 56-79). Ann Arbor: University of Michigan Press.

## Appendix A

### Integrated Pronunciation Activity for Segmental Practice

This activity (Darcy, Ewert, Chen, Wang, & Lidster, 2011) is designed for the beginner level (Level 1) and can be integrated within lessons that address learning outcomes such as “learning to spell for clarification” and “asking and getting directions.” Both language groups in this example classroom (Spanish and Arabic) had trouble with the <sh>/<ch> distinction both in terms of the sounds /ʃ/ and /tʃ/ and of their spelling. They were doing a shopping unit to practice numbers and common words as well as plurals. We took this opportunity to integrate three pronunciation components: practice of a difficult sound contrast, perception, and phoneme-grapheme links.

In preparation for the activity, we asked them to choose items they often bought at the store by using a picture dictionary. We organized often-mentioned items containing the critical sounds on a worksheet. We first said the word aloud, and they filled in the missing letters (either <ch> or <sh>) that correspond to the sound they heard, thus making *shoes*, *shorts*, *peaches*, *spinach*, and so forth.

Part 2 – Listening

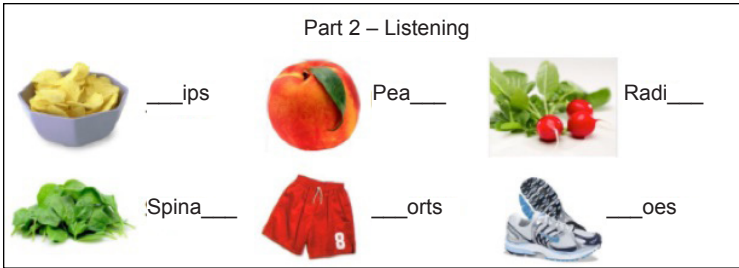

Next, we wrote out sentences that targeted the sounds. The students heard the first half of the sentence, “My teacher is from ...” and had to say, in this case, “Canada.” If they heard, “My T-shirt is from ...,” they would instead say, “China,” or wherever their T-shirts happened to be made. Similarly, “I was chopping ... (vegetables)” or “I was shopping ... (*for* vegetables)” encouraged the students to focus on phonological and grammatical forms at the same time.

A		B	
1. My <u>teach</u> er is from _____.	/	My T- <u>sh</u> irt is from _____.	
2. I was <u>ch</u> opping _____.	/	I was <u>sh</u> opping _____.	
3. I bought some <u>ch</u> erries for _____.	/	I bought some <u>sh</u> erries for _____.	
1. Sh / Ch	2. Sh / Ch	3. Sh / Ch	4. Sh / Ch
5. Sh / Ch	6. Sh / Ch	7. Sh / Ch	8. Sh / Ch

Last, we asked the students for their addresses and other common places they went to in Bloomington (our city) to shop. We then put them in a sentence (e.g., “University East apartments are on ‘*Mitchell Street*’”), and the students decided whether the street address, *Mitchell Street*, was said with an <sh> or <ch> sound. We used other landmarks around Bloomington to connect this sound and spelling distinction to their real lives as much as possible.

## Appendix B

### Linked Labyrinth

**Duration:** Approximately 15 minutes

This activity is appropriate for the beginner or low-intermediate levels and can include independent or pair work. This activity falls under the “guided” step in Celce-Murcia et al.’s (2010) communicative framework. Its skill focus is linking, helping learners figure out and learn whether words in phrases should be linked or not. This activity can include listening but can also be done with written sentences. It can be integrated into lessons about learning the placement of adjectives and nouns, learning about *a, an*, or about prepositions such as *of, in, about*.

A noticeable feature of this activity is that the feedback is “embedded” in the activity, because getting out of the labyrinth presupposes the successful perception and production of linking phenomena. Therefore, the successful completion of the task depends on sufficient control of the skill it targets. The list of sentences can be prepared either to indicate a route already (easier), or it can be left up to the students (at a more advanced level), who can make their own route (harder). Several such lists can be made, using for example different types of linking.





**Worksheet and Instructions:** Read each sentence out loud (or listen to each sentence), determining if each sentence has some linking or not. If it has, follow the ➞ or ⓪ arrows. If it does not, follow the ⋯➞ or ⓪ arrows. Which “secret sentence” do you reach at the end? Is it linked? Practice again if you are not sure.

**Materials:** One worksheet with empty boxes and lists of sentences. An example list of sentences (with correct answers and occurrences of linking underlined) is provided below. [Students get only the sentences, without the markings or the answer.]

- 1 An extra sheet of paper ( ➞ )
  - 2 A red pencil ( ⋯➞ )
  - 3 A beautiful jacket ( ⋯➞ )
  - 4 An amazing evening dress ( ➞ )
  - 5 An ordinary pair of shoes ( ➞ )
  - 6 Three small watches ( ⋯➞ )
- Secret sentence: ✂





Alternative for the secret sentence: The boxes may contain two-word sequences (with or without linking, for example, *Linda and Pete* versus *Linda’s mother*; *bought a* versus *bought some*; *red umbrella* versus *red shoes*); the final sentence can be combined from those bits.

↻ or U if the words are linked     → or ↓ if the words are not linked

Start here	→		↻		↻	
U	↓		↓		↓	U
	↻		→		→	
↓	U		U		U	
	→		↻		→	
U	↓		U		↓	
	↻		→		↻	
↓	U		↓		U	
						

Look below for the “secret sentence.” Read it out loud; is it the correct one? Is it linked or not? If it is, point out where.





Secret Sentence

-  *A beautiful view with tall trees*
-  *The weather is very cold as always*
-  *He told me some secrets*
-  *I called him after dinner*

## Appendix C

### Perception Practice Using Repetition and Vocabulary Links

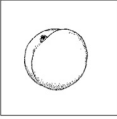
#### 1. Word-Matching Task (Perception/Lexical Access)

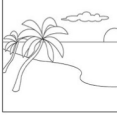
	 [pæn]		/æ/ - /ɛ/
	 [pi:tʃ]		/p/ - /b/
<b>A</b>		<b>B</b>	

Which word did you hear? Choose the picture A or B.





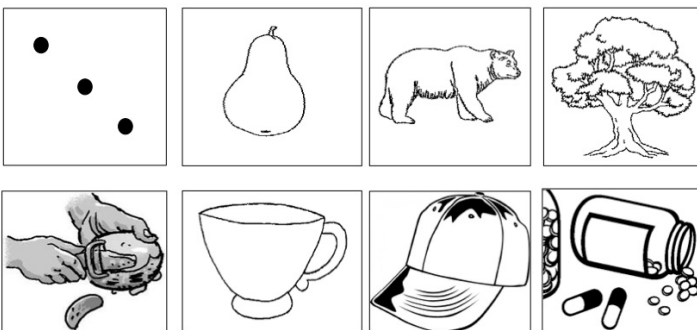



#### 2. Picture-Naming Task (Production/Lexical Retrieval)

Students pronounce the name of objects or activities shown on the pictures and receive feedback. All of these activities do not require spelling knowledge of the targeted words. They could usefully be extended to include more communicative contexts by having students try to create a short story using these words. The selection of pictures may require preliminary verification and adjustments to ensure that the word they elicit is not ambiguous (cf. the picture for “three,” which may be named as “dots” instead).



Picture-naming prompt containing the words *three*; *tree*; *pear*; *bear*; *peel*; *pill*; *cup*; and *cap*, targeting the contrasts /θ/-/t/, /p/-/b/, /i:/-/ɪ/, /ʌ/-/æ/.

### 3. Picture-Matching Task (Perception/Lexical Access)

  [stɪt]  [sti:t] Which pronunciation is correct?	  [ɪf]  [i:f] Which pronunciation is correct?	  [gɪft]  [gi:ft] Which pronunciation is correct?
--	--	--

Students listen and pick which pronunciation is “correct” for the picture. Practice items in this example target the /i:/-/ɪ/ contrast.

