

Assessing the Impact of Cognitive Manipulation Techniques on the Command and Control Process: An Exploration Based on QFD Model

Yazhou Sun (sxfyycsy@163.com)

Academy of Military Science, Military Science Information Research Center, 26 N. Fucheng Street
Beijing, 100142 China

Xiaosong Li (164832732@qq.com)

Academy of Military Science, Military Science Information Research Center, 26 N. Fucheng Street
Beijing, 100142 China

Abstract

Command and control is a key activity in a war that determines whether the war is won or lost. A person's cognition can influence the decisions he makes in command and control. In this paper, we propose a method to assess the impact of cognitive manipulation techniques in command and control. We divide command and control activities into eight segments and use a hierarchical latent Dirichlet allocation model in natural language processing to discover the most important cognitive manipulation techniques at present. We completed the assessment process using the Quality Function Deployment Model. The results of the assessment show that judgement, decision-making, and planning in the command and control perspective are susceptible to cognitive manipulation techniques; the tactical level is more susceptible to cognitive manipulation techniques than the strategic campaign. Life sciences, digital technology, and other fields play a key role in command and control research under cognitive manipulation.

Keywords: Cognitive manipulation; Command and control; Human decision making; Impact assessment

Instructions

At present, the world's unprecedented changes are accelerating, and the competition among the major Powers is becoming more and more intense. The cognitive domain, as the key to seizing comprehensive control, has become a new area of competition among the major Powers. Cognitive domain refers to the domain consisting of perception and reasoning, in which individuals and groups have interconnected beliefs, values and cultures (Yu, Yuanlai & Chen, Xi, 2022). Cognitive confrontation has become one of the recurring and popular themes in military terminology in recent years: the RAND think tank in the United States listed information and perception manipulation technologies as one of the eight emerging technological areas in a research report; NATO regards cognitive space as a more decisive sixth operational domain in addition to the five different operational domains of war: air, land, sea, space and cyber (Men, Honghua & Xu, Boya, 2022). Therefore, studying cognitive confrontation and cognitive manipulation technologies is of great significance in focusing on major issues in emerging fields and exploring breakthroughs and applications of cutting-edge technologies.

Command and control has always been a key element in military systems, and it is important to assess the ability of

cognitive manipulation technologies to influence the command and control process. In this paper, we use Hierarchical Latent Dirichlet Allocation (hLDA), combined with artificial analysis to get the key technologies in the field of cognitive manoeuvre; based on the PREA-OODA cycle model, we obtain the eight links of the command and control process. Based on the "PREA-OODA" loop model, the eight links of the command and control process were obtained. Based on the above, we constructed the evaluation index system and applied the Quality Function Deployment (QFD) method to analyse the influence of cognitive manipulation technology in the command and control process.

Cognitive manipulation refers to the process by which State and non-State forces, using a variety of techniques and instruments, attempt to influence the way individuals or groups think and behave. Currently, research on cognitive manipulation techniques focuses on both development and application. On the one hand, people are concerned about the development of cognitive manipulation techniques. R. M. Alguliev et al. explored the role of multimedia resources in Wikimedia information warfare and proposed a particle swarm algorithm with adaptive parameters that can enhance the influence of multimedia resources used for information warfare in Wikimedia (2014); Marcel Takac et al. investigated the role of multimedia resources in Virtual reality exposure (VRE). reality exposure (VRE) in which a cognitive model of emotion regulation is investigated, which provides a mental framework to inform and guide researchers and therapists, which will help advance the understanding of VRE (2021). On the other hand, the application of cognitive manipulation techniques has also been studied. Luo Jun's study analyses the application of cognitive manipulation based on online media from multiple perspectives based on the current communication reality and complex information ecology of online media, and proposes several countermeasures on this basis (2021); Robert McPhedran et al. proposed the concept of "psychological inoculation", and their experiments showed that Robert McPhedran et al. introduced the concept of "psychological inoculation", and their experiments showed that individuals who were pre-vaccinated with an intervention reduced their identification with misinformation, and this study provided new evidence

for the general effectiveness of inoculation interventions against false labelling (2023).

The QFD approach, also known as Quality Function Deployment, is a systematic decision-making technique. It weighs requirements and technical characteristics and enables prioritisation to make better decisions. QFD is widely adopted in economics, sociology, management and other fields, and related research is dominated by its application. Song Haowen et al. use the quality function deployment method based on grey correlation analysis to establish the quality house of unmanned intelligent safeguarding equipment capability demand analysis containing grey comprehensive correlation matrix, and obtain the importance ranking of unmanned intelligent safeguarding equipment capability indexes (2023). Suo Longlong, et al. constructed the reserve force base training quality evaluation index system and introduced social network analysis, verified the effectiveness of the method with examples, and provided methodological reference for the organisation of reserve force base training quality evaluation (2023). Lei Shuai et al. use the QFD method to construct a task-driven evaluation model of strategic intelligence research capability in national defence science and technology, and conduct case analysis to provide theoretical support for improving the task-based strategic intelligence research capability in national defence science and technology (2022).

In summary, on the one hand, research on the assessment of the ability to influence cognitive manoeuvring techniques in the command and control process is still relatively rare; on the other hand, the application of QFD methods has been more mature, and the effectiveness of the methods has been widely proved. This paper combines a variety of methods, which not only extends the application scope of QFD, but also provides reference for related work, and has certain theoretical innovation and practical exploration value.

Design of the Assessment Model

QFD Basic Theory

QFD was originally developed by Prof. Yoji Akao's team in Japan in 1966 while working for Mitsubishi Shipyard to enable better customisation of products and services to target markets and to accelerate growth. QFD was initially used primarily for quality management, but has since evolved to cover all areas of business operations and is now widely used in systems engineering, metrics evaluation and other research. The distinguishing feature of the QFD method is that all elements are combined in a graph and positioned relative to each other. feature is the combination of all elements in a graph and their positioning relative to each other. The core is the QFD matrix, which is usually presented in the form of a quality house. The quality house expresses the quality of the product that the customer needs in words and diagrams, and consists of six areas, including the roof, ceiling, left wall, right wall, room, and floor, and its structure is shown in Fig. 1.

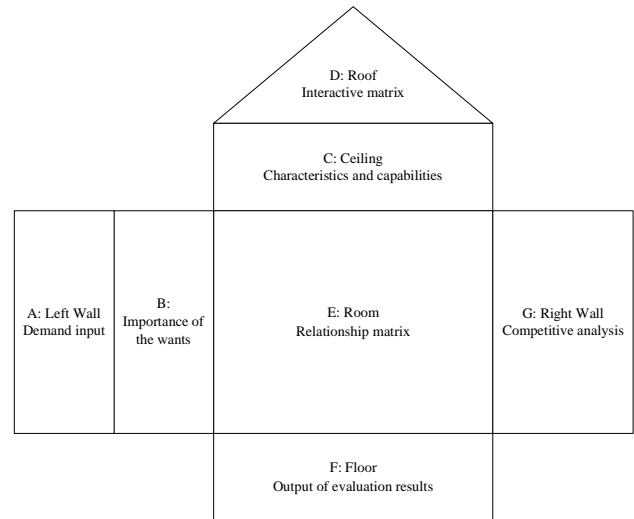

Figure 1: Prototype structure of a quality house.

The research idea of this paper is to assess the influence of cognitive manipulation technology in the command and control process based on the QFD method by taking each link of command and control as a demand and representative technology of cognitive manipulation as a capability. In conjunction with this paper's research, the structure of each component of the quality house is reshaped: the left wall of the quality house, A, represents each segment of the command and control process; the partition between the left wall and the room, B, indicates the importance of each segment of the command and control process; the ceiling of the quality house, C, represents the components of each technology of cognitive manipulation; the roof, D, is the interaction matrix between the capabilities of each technology; and the room in the middle, E, indicates the command and control process segments relationship matrix with the cognitive manipulation techniques, which is the core of the study; the floor F of the quality house represents the evaluated value of each technique; and the right wall G represents the matrix of competing analyses of demand.

Assessment Model

In this paper, the influence assessment model of cognitive manipulation technology in the command and control process is constructed based on the QFD method, and the logical framework is shown in Figure 2. Among them, based on the "PREA-OODA" cycle model of command and control, the key link indicators of the command and control process are obtained. Using the hLDA topic discovery model, combined with expert analysis, the representative key technical indicators in the field of cognitive manipulation are obtained. On this basis, the QFD quality house is constructed, and the influence capability of cognitive manipulation technology based on the command and control process is evaluated according to the interaction matrix and relationship matrix, and the influence capability evaluation results are finally obtained.

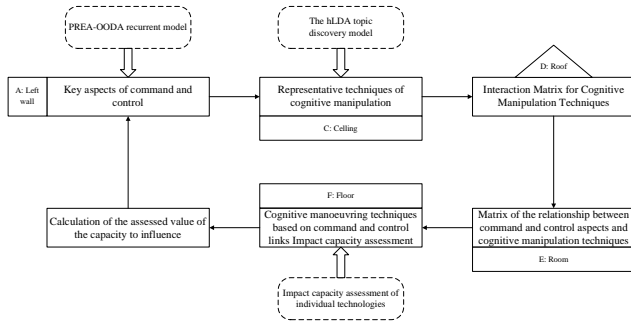

Figure 2: Logical framework of the assessment model.

Construction of the Assessment Indicator System

Key Aspects of Command and Control

Whether it is traditional war, modern war or future war, command and control has always been a key element in the military system, which is directly related to the victory or defeat of military operations. War contains three levels: strategic, operational and tactical, and command and control runs through them, and has its basic paradigm at each level. At the tactical level, command and control is based on the classic "Observation - Judgement - Decision - Action" concept. "The OODA concept is the guide. The victory or defeat of an armed conflict depends on which of the two opposing sides can complete the OODA loop faster and better, and the mechanism of command confrontation is to obtain a comparative advantage in the speed of the OODA loop operation (Shen, B., Wu, W.L., Yang, G. & Zhou, X.S., 2023). At the operational and strategic levels, war is a confrontation between multiple military systems, and the basic process of command and control can be divided into "Planning - Readiness - Execution - Assessment". Assessment" PREA ring model. Therefore, the basic paradigm of command and control can be summarised as the "PREA-OODA" loop model, the process of which is shown schematically in Figure 3.

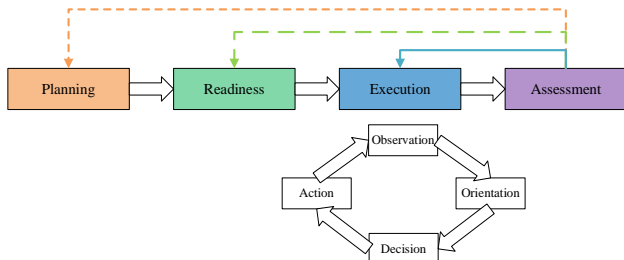

Figure 3: Basic paradigm of command and control.

Main Techniques of Cognitive Manipulation

Cognitive manipulation technology is an umbrella term that encompasses many technological tools and methods in the fields of life sciences, social sciences, engineering and technology. In this study, we consider the hLDA topic

discovery model combined with expert wisdom to get the key technology system of cognitive manipulation. hLDA is a hierarchical topic discovery model, which is capable of topic mining the raw corpus and obtaining hierarchical topic results. hLDA adopts Bayesian approach to generate the corresponding prior through the distributions on the partitions, and the process is schematically illustrated in Fig. 4.

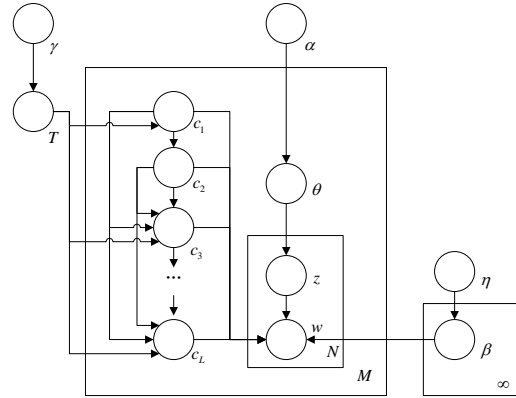

Figure 4: Schematic of the hLDA model.

In this paper, relevant reports and papers from foreign authorities and well-known scholars such as the United States Air Force University, Allied Transformation Command, and the Institute of Foreign Relations of the Council of Europe in recent years are selected as the original corpus of hLDA model, and the size of the whole corpus is more than 86,000 words.

The raw data were processed using the NLTK tool, and the corpus was subjected to clause splitting, removal of punctuation and numbers, stemming extraction, and word form reduction. A deactivation word list is constructed to remove deactivated words to form the hLDA input file. The input corpus is processed based on the hLDA topic discovery model to obtain the hierarchical analysis results of the key techniques of cognitive manipulation, see Table 1.

Table 1: Cognitive manipulation key technology hierarchical mining results.

Level	Topic words (Top 8)
1	Information, technology, use, possible, impact, way, public, emerging
2	Operational, national, military, special, joint, psychological, information, agent
3	Media, social, disinformation, russia, influencers, government, campaign, united
3	Information, military, forces, operations, systems, NATO, decision making, cognition
2	Conspiracy, theory, media, social, data, online, analysis, language
3	Model, conspiracy, position, hybrid, theory, modelling, theme, performance
3	Narrative, greatness, humanity, body, industry, government, revolution, rand
3	Cognition, user, virtual reality, mood, emotion, brain, capability, technology
3	Customer, forum, quality, manipulation, online, rating, cost, opinion
3	Vaccine, group, security, authority, distrust, public, conspirators, fear
3	Deception, quantum, GPS, navigation, email, sabotage, computation, principles
2	Theory, engagement, information, microtargeting, research, media, Facebook, negativity
3	Big Data, Analytics, Agencies, Security, Apps, Defence, Systems, Forces
3	Misinformation, user, social, discovery, content, network, correction, research

According to Table 1, analysing the keywords, it can be seen that the results of hLDA theme discovery basically

reflect the key technologies in the field of cognitive manipulation. For example, the keyword "social, disinformation" reflects the role of social media disinformation in the field of cognitive manipulation; the keyword "virtual reality, emotion" reflects the use of virtual reality technology to manipulate emotions; the keyword "big data, analysis" reflects the application of big data analysis technology in cognitive manipulation; and so on. On the basis of the results in Table 1, combined with literature and expert wisdom, we constructed a key technology system for cognitive manipulation, as shown in Figure 5. We have given these technologies designations ranging from "T1" to "T8".

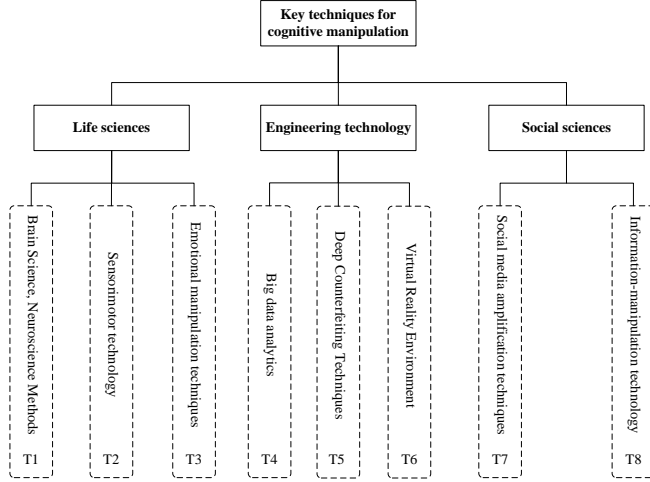

Figure 5: Key techniques for cognitive manipulation.

Process and Results of the Assessment

The weights of the eight key aspects of command and control are determined using the AHP hierarchical analysis method. The AHP is capable of integrating qualitative and quantitative analyses to assess multi-objective complex problems. 1-9 The scale method obtains quantitative relative importance values through two-by-two comparisons between factors, the rules of which are shown in Table 2.

Table 2: 1-9 Scale method.

Scale	Connotation
1	Indicates that two factors are of equal importance compared to each other
3	Indicates that the former is slightly more important than the latter when comparing the two factors
5	Indicates that when two factors are compared, the former is significantly more important than the latter
7	Indicates that the former is more strongly important than the latter when comparing the two factors.
9	Indicates that the former is more important than the latter when comparing the two factors.
2, 4, 6, 8	Indicates the median value of the above neighbouring judgements
reciprocal	If the ratio of the importance of factor i to factor j is d_{ij} , then the ratio of the importance of factor j to factor i is $d_{ji} = 1/d_{ij}$.

Based on the wisdom of the experts, an 8th order judgement matrix for key aspects of command and control was constructed using a 1-9 scale:

$$D = (d_{ij})_{8 \times 8} = \begin{pmatrix} 1 & 2 & 0.14 & 0.25 & 3 & 0.5 & 0.33 & 0.2 \\ 0.5 & 1 & 0.25 & 0.33 & 2 & 0.33 & 0.25 & 0.2 \\ 7 & 4 & 1 & 4 & 5 & 4 & 3 & 2 \\ 4 & 3 & 0.25 & 1 & 3 & 2 & 0.5 & 0.33 \\ 0.33 & 0.5 & 0.2 & 0.33 & 1 & 0.5 & 0.33 & 0.2 \\ 2 & 3 & 0.25 & 0.5 & 2 & 1 & 0.33 & 0.33 \\ 3 & 4 & 0.33 & 2 & 3 & 3 & 1 & 0.33 \\ 5 & 5 & 0.5 & 3 & 5 & 3 & 3 & 1 \end{pmatrix}$$

Calculate the weight of each indicator of command and control to obtain the results of the hierarchical analysis of the key aspects of command and control, see Table 3.

Table 3: AHP hierarchical analysis results.

Aspect	Weight	Sort	Maximum eigenvalue λ
Planning	0.0523	6	8.5286
Readiness	0.0423	7	
Execution	0.3106	1	
Assesment	0.1087	4	
Observation	0.0356	8	
Orientation	0.0744	5	
Decision	0.1402	3	
Action	0.2359	2	

The consistency test of the results is usually performed using the CR value as a test criterion. The consistency test is passed when the CR is less than 0.1 and the results can be used. The formula for CR is as follows:

$$CR = \frac{CI}{RI} = \frac{\lambda - n}{n - 1} / RI$$

Checking the table, we can see that when n is 8, the RI value is 1.41. According to Table 3, we can see that the maximum eigenvalue λ is 8.5286. Substituting the above two values into the equation, we can get the result of CR calculation as 0.0536, which is in line with the requirement of consistency test, so the result is valid. Therefore, the weights of the eight key aspects of command and control are finally obtained:

$$E = (e_1, e_2, \dots, e_8) = (0.0523 \quad 0.0423 \quad 0.3106 \quad 0.1087 \quad 0.0356 \quad 0.0744 \quad 0.1402 \quad 0.2359)$$

The interaction matrix of the key technologies of cognitive manipulation is denoted by $T = (t_{ij})_{8 \times 8}$, where t_{ij} refers to the degree of influence of technology i on technology j . The rules for evaluating the degree of influence are shown in Table 4.

Table 4: Rules for evaluating the level of impact.

Scale	Connotation
-1 ~ 0	Negative correlation, when one technique improves, the other decreases
0	No correlation, when one technique is improved, the other technique is not affected.
0 ~ 1	Positive correlation, when one technology improves, the other also improves

By reviewing professional information and consulting experts, the interaction matrix of the 8 key technologies of cognitive manipulation is constructed as follows:

$$T = (t_{ij})_{8 \times 8} = \begin{pmatrix} t_{11} & \dots & t_{18} \\ \vdots & \ddots & \vdots \\ t_{81} & \dots & t_{88} \end{pmatrix} = \begin{pmatrix} 1 & 0.7 & 0.8 & 0.05 & 0.1 & 0.3 & 0.2 & 0.2 \\ 0 & 1 & 0.2 & 0.02 & 0.1 & 0.5 & 0.25 & 0.2 \\ 0 & 0.1 & 1 & 0.01 & 0.1 & 0.4 & 0.2 & 0.15 \\ 0.4 & 0.4 & 0.4 & 1 & 0.8 & 0.7 & 0.5 & 0.5 \\ 0 & 0.1 & 0.1 & 0 & 1 & 0.2 & 0.5 & 0.6 \\ 0 & 0.35 & 0.5 & 0.1 & 0.3 & 1 & 0.2 & 0.3 \\ 0 & 0 & 0.1 & 0 & 0 & 0 & 1 & 0.2 \\ 0 & 0.3 & 0.3 & 0 & 0.2 & 0.2 & 0.4 & 1 \end{pmatrix}$$

Analysing this matrix, it can be seen that brain science and neuroscience technology have a greater positive impact on perception manipulation and emotion manipulation technology; the development of big data analysis technology has an important positive contribution to the enhancement of deep forgery technology and virtual reality technology. In addition, deep forgery technology also has a greater impact on social media amplification and information manipulation technology.

Relationship Matrix Between Command and Control Aspects and Cognitive Manipulation Techniques The relationship matrix between the command and control key link and the cognitive manipulation key technology is denoted by A, where B represents the degree of correlation between link C and technology D. The construction rules of the relationship matrix are shown in Table 5.

Table 5: Rules for constructing relationship matrices.

symbolic	Scale	Connotation
◎	5	Strongly relevant
○	3	Moderately correlated
△	1	Weakly correlated
×	0	Uncorrelated

Based on the rules, relevant experts were invited to judge the relationship between the key aspects of command and control and the key technology of cognitive manipulation, and the data are shown in Table 6.

Table 6: Relational judgement data.

Aspect	T1	T2	T3	T4	T5	T6	T7	T8
Planning	○	○	△	◎	◎	△	◎	△
Readiness	○	△	△	◎	△	◎	○	◎
Execution	△	△	○	△	×	×	×	△
Assesment	△	△	△	○	△	△	△	△
Observation	○	◎	×	×	○	◎	×	○
Orientation	◎	△	○	○	○	○	×	△
Decision	○	△	◎	△	△	△	△	△
Action	△	△	○	△	△	△	△	×

Based on the relationship judgement in Table 6, the relationship matrix of command and control key aspects and cognitive manipulation key technologies is constructed as follows:

$$R = (r_{ij})_{8 \times 8} = \begin{pmatrix} r_{11} & \dots & r_{18} \\ \vdots & \ddots & \vdots \\ r_{81} & \dots & r_{88} \end{pmatrix} = \begin{pmatrix} 3 & 3 & 1 & 5 & 5 & 1 & 5 & 1 \\ 3 & 1 & 1 & 5 & 1 & 5 & 3 & 5 \\ 1 & 1 & 3 & 1 & 0 & 0 & 0 & 1 \\ 1 & 1 & 1 & 3 & 1 & 1 & 1 & 3 \\ 3 & 5 & 0 & 0 & 3 & 5 & 0 & 3 \\ 5 & 1 & 3 & 3 & 3 & 3 & 0 & 1 \\ 3 & 1 & 5 & 1 & 1 & 1 & 1 & 1 \\ 1 & 1 & 3 & 1 & 1 & 1 & 1 & 0 \end{pmatrix}$$

Analysis Matrix It is known that: brain science and neuroscience technology, big data analysis technology, and information manipulation technology are the three cognitive manipulation technologies that play a relatively large role in the process of command and control; brain science and neuroscience technology, and perceptual manipulation technology can have an impact on each link of command and control; of the eight links of command and control, the execution stage is the link that is relatively less affected by cognitive manipulation technology, while planning, preparation, judgement, decision-making and other links involving more cognition and emotion are relatively more susceptible to the influence of cognitive manipulation technology.

The relationship matrix B is corrected using the cognitive manipulation technique interaction matrix A. The correction matrix formula is given by the following equation:

$$R' = R \times T = (r_{ij})_{m \times n} \times (t_{ij})_{n \times n} = (r'_{ij})_{m \times n}$$

Calculated and normalised:

$$R^* = \begin{pmatrix} 0.75 & 0.76 & 0.53 & 0.92 & 0.99 & 0.65 & 0.99 & 0.77 \\ 0.75 & 0.79 & 0.91 & 0.99 & 0.74 & 0.99 & 0.79 & 0.99 \\ 0.01 & 0.01 & 0.01 & 0.08 & 0.01 & 0.01 & 0.01 & 0.01 \\ 0.17 & 0.23 & 0.03 & 0.49 & 0.36 & 0.26 & 0.31 & 0.43 \\ 0.34 & 0.99 & 0.42 & 0.01 & 0.51 & 0.77 & 0.36 & 0.63 \\ 0.99 & 0.67 & 0.99 & 0.58 & 0.67 & 0.72 & 0.38 & 0.51 \\ 0.42 & 0.28 & 0.74 & 0.12 & 0.20 & 0.31 & 0.25 & 0.21 \\ 0.01 & 0.03 & 0.08 & 0.10 & 0.13 & 0.12 & 0.13 & 0.02 \end{pmatrix}$$

Results of the Evaluation Based on the normalised modified relationship matrix A and the weighting result E for the key aspects of command and control, the result F for the assessment of the impact capacity of cognitive manipulation techniques is given by the following equation:

$$F = (R^*)^T \times E^T$$

Calculating the above equation, the result:

$$F = (0.24, 0.23, 0.28, 0.25, 0.25, 0.26, 0.23, 0.23)^T$$

can be obtained. each value in F is the result of the assessment of the influence ability of each key technology of cognitive manipulation on command and control. On the basis of the above work, the QFD quality house for the assessment of cognitive manoeuvring technology's ability to influence command and control is finally constructed, see Figure 6.

Technology Interaction Matrix												
Aspect	Weight	Life sciences			Engineering technology			Social sciences		Exposure	Weighted exposure	Sort
		T1	T2	T3	T4	T5	T6	T7	T8			
Planning	0.05	0.75	0.76	0.53	0.92	0.99	0.65	0.99	0.77	6.36	0.32	3
Readiness	0.04	0.75	0.79	0.91	0.99	0.74	0.99	0.79	0.99	6.95	0.28	4
Execution	0.31	0.01	0.01	0.01	0.08	0.01	0.01	0.01	0.01	0.15	0.05	8
Assessment	0.11	0.17	0.23	0.03	0.49	0.36	0.26	0.31	0.43	2.28	0.25	5
Observation	0.04	0.34	0.99	0.42	0.01	0.51	0.77	0.36	0.63	4.03	0.16	6
Orientation	0.07	0.99	0.67	0.99	0.58	0.67	0.72	0.38	0.51	5.51	0.36	1
Decision	0.14	0.42	0.28	0.74	0.12	0.20	0.31	0.25	0.21	2.53	0.35	2
Action	0.24	0.01	0.03	0.08	0.10	0.13	0.12	0.13	0.02	0.62	0.15	7
Absolute influence		0.24	0.23	0.28	0.25	0.25	0.26	0.23	0.23			
Relative influence		12.13	11.78	14.37	12.76	12.76	13.16	11.58	11.48			
Sort		5	6	1	4	3	2	7	8			

Figure 6: Impact capacity assessment quality house.

Conclusion

Based on the impact capacity assessment quality house constructed in Figure 6, we analyse the results of the impact capacity assessment of cognitive manipulation techniques in the command and control process.

Cross-sectional analyses of quality houses can yield assessments of the extent to which key aspects of command and control are affected by cognitive manipulation techniques. (1) Analyse the degree of influence of the link itself. According to the relationship matrix of the Quality House room, it can be understood that the top three links that are most likely to be affected by cognitive manipulation techniques are preparation, planning, and judgement, and the execution and action links are less affected. (2) Considering the role of links in the whole command and control process, the affected degree of each link of the command and control process is analysed. According to the relationship matrix between the weights of the left wall of the quality house and the rooms of the quality house, it can be understood that in the command and control perspective, the order in which each link is affected by cognitive manipulation techniques is judgement, decision-making, planning, preparation, assessment, observation, action, and execution in that order. Among them, judgement, decision-making and planning are not only the more critical 3 links in command and control, but also require more human subjective participation, and thus are easily affected by cognitive manipulation techniques, which can be proved by the evaluation results of Quality House. (3) Analysed at the strategic campaign and tactical levels. The tactical level has a shorter cycle, a relatively simpler structure, and a greater proportion of subjective human awareness, and is therefore more susceptible to cognitive manipulation techniques, which is consistent with the results of the Quality House assessment.

Longitudinal analyses of the quality houses yielded an assessment of the ability of cognitive manipulation techniques to influence the command and control process. (1) Emotional manipulation technology (T3), virtual reality technology (T6), and depth forgery technology (T5) are the top three technologies in the order of their ability to influence the command and control process. The above mentioned technologies can be used as the focus direction for developing cognitive manipulation and cognitive confrontation. (2) According to the output results of the quality house, the

ability of each key technology of cognitive manipulation to influence the command and control process does not differ much, and none of the directions can be ignored. (3) Analysed by subject areas, technologies in the fields of life sciences and engineering technology (especially digital technology) have a greater ability to influence the command and control process. Therefore, paying attention to the research progress and technological development in the fields of life sciences and digital technology plays a key role in the study of cognitive manipulation and cognitive confrontation in the command and control process.

Acknowledgments

This work is supported by National Natural Science Foundation of China (72074219) and the National Social Science Fund of China (23ZDA119).

References

- Yu, Yuanlai & Chen, Xi. (2022). Mechanisms of Effectiveness and Strategy Selection in Cognitive Domain Combat. *Frontiers of Thought and Theory*, 4, 128-139.
- Men, Honghua & Xu, Boya. (2022). The strategic layout of the US cognitive domain and the great power game. *Modern International Relations*, 6, 1-11+61.
- R. M. Alguliev, R. M. Aliguliyev & I. Ya. Alekperova. (2014). Cluster approach to the efficient use of multimedia resources in information warfare in wikimedia. *Automatic Control and Computer Sciences*, 2, 97-108.
- Marcel Takac, James Collett, Russell Conduit & Alexander De Foe. (2021). A cognitive model for emotional regulation in virtual reality exposure. *Virtual Reality*, 1, 1-14.
- Luo, Jun. (2021). Core issues of online information dissemination security: cognitive manipulation and coping strategies in the Internet era. *Academic Forum* (02), 25-40.
- McPhedran Robert, Ratajczak Michael, Mawby Max, King Emily, Yang Yuchen & Gold Natalie. (2023). Psychological inoculation protects against the social media infodemic.. *Scientific reports*, 1, 5780-5780.
- Song, Haowen, Hongli Jia, Guangyao Lian, Yu Zhang & Shan Wang. 2011 A new species of the genus *Pseudourostyla* (Hymenoptera, Braconidae) from China. (2023). GQFD-based capability requirement analysis of unmanned intelligent safeguard equipment. *Computer Measurement and Control*, 6, 117-122.
- Solonglong, Jia Hongli & Koo Huining. 2011 A new species of the genus *Pterocarpus* (Coleoptera, Staphylinidae) from China. (2023). Quality evaluation of base-based training for reserve forces based on improved QFD. *Military Operations Research and Evaluation*, 2, 17-22+46.
- Lei, Shuai, Xinran Peng & Xiaosong Li. 2011 A new species of the genus *Pseudourostyla* (Hymenoptera, Staphylinidae) from China. (2022). Evaluation of Strategic Intelligence Research Capability of National Defence Science and Technology Based on QFD. *Intelligence Theory and Practice*, 2, 55-60.

Shen, B., Wu, W.L., Yang, G. & Zhou, X.S.. (2023). Intelligent evaluation model and method for unmanned cluster system based on group OODA. *Journal of Aeronautics*, 14, 263-278.