

# EXPERT VARIANCE: DIFFERENCES IN SOLVING A DYNAMIC ENGINEERING PROBLEM<sup>1</sup>

Michael Prietula  
Computer and Information Science Program

Frank Marchak  
Department of Psychology

Dartmouth College  
Nathan Smith Building  
Hanover, NH 03755

In this research we examine how expert engineers differ in solving a specific engineering problem. This effort arose out of observations and experiences with a project originating at the Center for Advanced Engineering Study at the Massachusetts Institute of Technology. In this previous project, one of us developed a simulation as part of a National Science Foundation effort to study new approaches to continuing education for practicing engineers and scientists in industry.<sup>2</sup> During the development of the simulation, it became apparent that this simulation presented a quite interesting environment to study how people reason about complex, physical systems. As a consequence, we are using a version of this simulation to investigate a variety of phenomena in engineering problem solving. This paper reports on some of our initial findings. Specifically, we examine the concept of "expert variance" with respect to one aspect of problem solving: the strategies evidenced by the sequence of steps used to solve the problem.

## METHOD

**Subjects.** Four engineering professors from the Thayer School of Engineering at Dartmouth College participated in the study. Each held a Ph.D. degree or the equivalent and had a minimum of 15 years experience in teaching and/or industry.

**Materials.** The steam system was reimplemented on an Apple Macintosh<sup>®</sup> computer. The simulated system (see Figure 1) depicted both components (via icons) and flows of steam and condensate (the numeric values). Two boilers burn fuel to heat the feedwater and produce steam to be fed at high pressures into the high-pressure header (HPH) for distribution. Steam output from the HPH feeds into a pump, a turbogenerator (for the production of electricity) and, if too much high-pressure steam is being produced, into a pressure reducing valve (which reduces the pressure and shunts it to the next header). Intermediate-pressure steam is produced by the third boiler and fed into the intermediate-pressure header (IPH). The IPH distributes steam to the process, a crusher, a second turbogenerator, and a second pressure reducing valve. The low pressure header is fed by both turbogenerators, the crusher, the pump, and a pressure reducing valve. The low pressure header (LPH) provides a second input to the process, feeds the deaerator, and a vent (excess steam is shunted to the atmosphere). Steam condensate is fed back to the deaerator from a turbogenerator and the process. Loss of water from the system is handled through a makeup water source. The deaerator prepares the returned condensate and excess steam for reintroduction to the boilers. Subjects used a mouse to manipulate a pointer on the screen, enabling them to

select components. For each component, the options of changing its current operating value or finding its current cost was available. In addition, the current and prior total system costs were continuously displayed as was the balance of the system. When a value was changed by a subject, the input value was first evaluated to insure it met the constraints associated with that component. Next the system was updated, which involved calculating the new cost for both the device and the entire system, updating these values, and searching for and indicating on the screen the exact sources of imbalance (if any). Further, the new value, the device involved and the current time were recorded to provide a trace of the subject's manipulations.

**Procedure.** The subjects were faced with the following problem:

*The system, in its initial configuration, is operating in a very inefficient manner. Attempt to minimize the cost of running the system by redirecting and modifying the flows of steam and condensate subject to the constraints of the system indicated in the written materials supplied.*

Given a description of the system and related equations, the subjects interacted with the simulation, verbally describing their actions and reasoning. The optimal value was not initially presented. After approximately thirty minutes or when the subject indicated that a solution had been reached, the optimal value for the system configuration was presented. Provided this goal had not already been met, the subject was asked what other changes could be made to his configuration to attempt to reach this goal. The subject then made further modifications to the system or described what strategies would be employed to meet this criterion. An entire session lasted approximately one hour.

## SUMMARY OF RESULTS

The analysis of the data consisted of the examination of the modification trace, experimenter observations, and recorded verbal protocol in order to determine (1) the nature of the components of reasoning and (2) how expert reasoning differed based on the identified components.

**Components of Reasoning.** Analysis of the components of reasoning indicated that experts similarly relied on three primary types of knowledge brought to bear in solving this problem: knowledge of **devices**, knowledge of **systems** of devices, and knowledge of **strategies** of energy conservation regarding systems and **devices**.<sup>3</sup>

Knowledge of **devices** (i.e., components) embodied the types of physical objects which may be found in a typical processing plant relying on steam use (e.g., turbogenerators, pressure reducing valves, vents). We found that three types of device "roles" were evidenced in solving the problems. First, there is the *structural* role where the device is simply described in terms of its particular properties. This is similar to Kuiper's<sup>4</sup> interpretation, but in this context applicable to the device level. For example, a "boiler" device may be described as a steam producing object which ingests fuel and feedwater, operates at some level of efficiency, and provides steam at some rate and pressure. A particular boiler device has properties instantiated to specific values (e.g., burns oil, is 80% efficient, produces steam at 110,000 lbs/hr), but also would have a specific purpose and function in the context of the behavior of the entire system. This is similar to Kuiper's *functional* description. However, we found that devices take on different functional descriptions based on their role in a particular strategy. For example, a boiler is a steam producing device -- its purpose is to generate steam to be propogated throughout the

system. Subjects occasionally used boilers "to balance" rather than purely "to produce." This is a subtle difference, but one reflecting a very particular role assigned to a boiler usually reserved for vents or pressure reducing valves. In this case, the additional role taken on by the boiler was determined by constraints inherent in a particular strategy and permitted by the understanding of the functioning of the device.

Knowledge of systems is knowledge of configurations. It refers to knowledge of how collections of devices operate together as a system. There are two characteristics which seem to distinguish knowledge of systems from knowledge of devices: interaction and collective purpose. *Interaction* refers to the propagation of effects, feedback, and interdependencies of several devices. Essentially, this reflects the appreciation of the dynamics and interconnectivity of the problem. *Collective purpose* refers to the attribution of a purpose to a collection of devices in the context of the system. For example, using a high level of abstraction, a simple description of the overall system behavior can be made by defining the plant as a set of interconnected systems which (1) produce steam, (2) distribute steam, (3) consume steam, (4) produce electricity, and (5) consume electricity. This representation reflects the devices, their role in the system, and the topology of the system indicated by connectivity flows.

The subjects also demonstrated knowledge of general strategies of energy conservation to be applied in reducing energy waste and monetary loss. Two dominant strategies were identified: (1) decrease FUEL Cost -- *minimize the cost of purchasing fuel for boilers*, and (2) generate ELECTRICITY -- *generate as much electricity inhouse as possible*. These two strategies correctly address the major sources of cost savings in the simulation. In addition, two additional strategies were identified, but served more of an ancillary or tuning role than the prior two: (3) attend to PRVs -- *pressure reducing valves (PRVs) should be used mainly as an intermediate control method to maintain steam balance* and (4) attend to VENTS -- *venting steam should be avoided and used only as a temporary mechanism to handle steam fluctuations*.

In summary, the experts relied on similar types of knowledge: of devices, systems, and strategies to achieve low cost solutions.

**Source of Expert Variance.** Three basic differences between experts were found. First, they differed in their ability to generate a minimum cost solution in the absence of an explicit goal (recall that the system was presented to the subjects without the minimum goal cost initially available). Second, the experts differed in the dominant strategy selected (of the first two previously mentioned). Third, they differed in the way the particular strategy was implemented.

**Cost Reduction.** Two subjects (S1 and S2) did not reach the minimum and, consequently, were then shown the goal and permitted to make further adjustments. In both cases, the subjects quickly achieved the minimum cost after the goal was presented. On the other hand, the other two subjects (S3 and S4) did successfully achieve the minimum cost without the goal present.

**Overall Strategies.** S1 and S2 differed in their initial attack of the problem. S1 incorporated the FUEL-oriented strategy by attempting to base-load (i.e., increase the output of the boiler to the maximum) the cheaper-fueled boilers and reduce the load on the expensive boiler. When S1 was shown the goal cost (indicating

that additional cost reductions could occur), attention was immediately paid to the turbogenerators and the ELECTRICITY strategy unfolded to permit the proper adjustments. S1 basically approached the task with the idea that lowering the cost of the boilers and redirecting steam were the most important things to do. This caused S1 to achieve a "local" minimum but not a global one. Only after the explicit goal was presented did the explicit "power vs. oil" tradeoff correctly occur. On the other hand, S2 immediately began by invoking the ELECTRICITY strategy and attempted to generate as much electricity as possible while balancing the system via the PRVs and the vent. Again, S2 did not achieve the minimum cost and was shown the goal. Almost in converse fashion from S1, S2 then focused on inhouse electrical production and continued to manipulate the flow parameters of the turbogenerator outputs in order to maximize the amount of power purchased within the constraints of the balanced system and level of steam production.

S3 and S4 both achieved the minimum cost solution without requiring the goal to be presented; however, they accomplished this quite differently. S3 was very methodical and essentially incorporated a strategy which was a combination of the ELECTRICITY and FUEL approaches. S3 attempted to produce as much electricity as possible while at the same time minimizing the use of the expensively-fueled boiler and balancing the adjustment with the vent. S4, however, was unique. With a minimum number of moves, S4 sequentially invoked the FUEL and ELECTRICITY strategies. S4 definitely was the quickest and most efficient of the subjects.

Implementation. An additional observation can now be made concerning how the strategies were implemented. The strategies identified involve adjustments to several devices at a time. For example, to increase the electricity both turbogenerators are involved along with one or more boilers -- thus defining the *device set* of the strategy. We found that the subjects took essentially two approaches to implementing a strategy and adjusting the device set. In one method, a subject would select a strategy, such as ELECTRICITY, and implement it "component- by-component" in a cautious manner where one element of the device set would be changed (e.g., a turbogenerator), the results tested (i.e., is it in balance?), and, if necessary, adjustments made to balance the system (to either members or nonmembers of the device set). The subject would then move on to the next device modification in the strategy (e.g., the other turbogenerator). This reflects a **locally-guided** approach sensitive to imbalances as the strategy unfolds. Subject S3 demonstrated this perfectly by attempting to explicitly balance the system on four separate occasions. On the other hand, the second type of implementation tolerated intermediate imbalances as each component of the device set was addressed. In this **globally-guided** approach, the subjects would first make adjustments to all members of the device set prior to any attempt to balance the results by adjusting nonmember components. The extreme case is illustrated by S4 who essentially was not concerned with balancing the system until the final adjustments were made. In one sense, a locally-guided search represents a cautious tactic by testing the effects of the device set adjustments. The globally-guided tactic seemed to reflect both a more optimistic confidence in the presumed behavior of the system and a commitment to a specific series of modifications.

## CONCLUSION

Expertise is more than a large accumulation of facts; it concerns basic qualitative differences in the representation of knowledge and the control of the reasoning processes. The analysis of expert reasoning, as we have indicated, uncovers a picture of comparisons which is more complicated than simple expert-novice dichotomies often suggest. As expected, experts as a group distinguish themselves (or are distinguished) from the flock via performance. They do what they do more proficiently and efficiently than the others. They have mastered the body of knowledge upon which proficiency is built. Experts, however, do not only know more -- they know differently. Humans are limited in their ability to deal with large amounts of information; consequently, they must incorporate ways to reduce the demands of the task during performance. It is precisely *because* of such cognitive limitations that experts have adapted efficient ways to solve problems in their domains. Expert problem solvers have augmented and modified their knowledge through years of experience. Lack of this experience often makes problem solvers "knowledge rich but strategy poor." More relevant to this discussion, it also provides a source for individual variation among experts. Experts in the same field simply may not demonstrate the same reasoning behaviors.<sup>5</sup> Experience, then, is both a source of expert performance and expert variance.

We have reported some of our initial findings regarding the nature of expert variance in problem solving. There are, of course, many additional avenues to pursue. For example, we are examining expert-novice differences, explicating more detailed information on the nature of the qualitative and causal judgements underlying the selection and execution of the strategies, and have implemented an OPS5 model of the strategies. We shall see...

## FOOTNOTES

<sup>1</sup> This project was supported by a grant from the Control Data Corporation, Education and Training Research Group. We express our appreciation to Frank Roberts of CDC, the Schools of Engineering at Dartmouth and MIT for their cooperation and support as well as Professor Michael Mohr of MIT.

<sup>2</sup> Project PROCEED (Program for Continuing Engineering Education) is a National Science Foundation effort in conjunction with the Center for Advanced Engineering Study at MIT. The purpose of Project PROCEED is to develop and demonstrate a nation-wide system for continuing education in industry by developing educational materials based on detailed case studies of actual engineering problems.

<sup>3</sup> It is also certain that the experts commonly relied on basic thermodynamic concepts such as energy and material balance, enthalpy, heat rate, and power generation; however, this evidence was generally always implicit in their interpretation of system behavior and function and rarely expressed. In fact, it is this knowledge which underlies the nature of causality and explanation on a device level. The next step in the research is to examine this level of reasoning.

<sup>4</sup> Kuipers, B. Commonsense reasoning about causality: Deriving behavior from structure, *Artificial Intelligence*, 24, 1984.

<sup>5</sup> Feltovich, P. *Knowledge-based components of expertise in medical diagnosis*. Ph.D. dissertation, University of Minnesota, 1981 (Published as University of Pittsburgh, LRDC Report PDS-2, September 1981) and Prietula, M. *An investigation of reasoning methods used in physical database design problem solving*, Unpublished Ph.D. dissertation, University of Minnesota, April 1985.

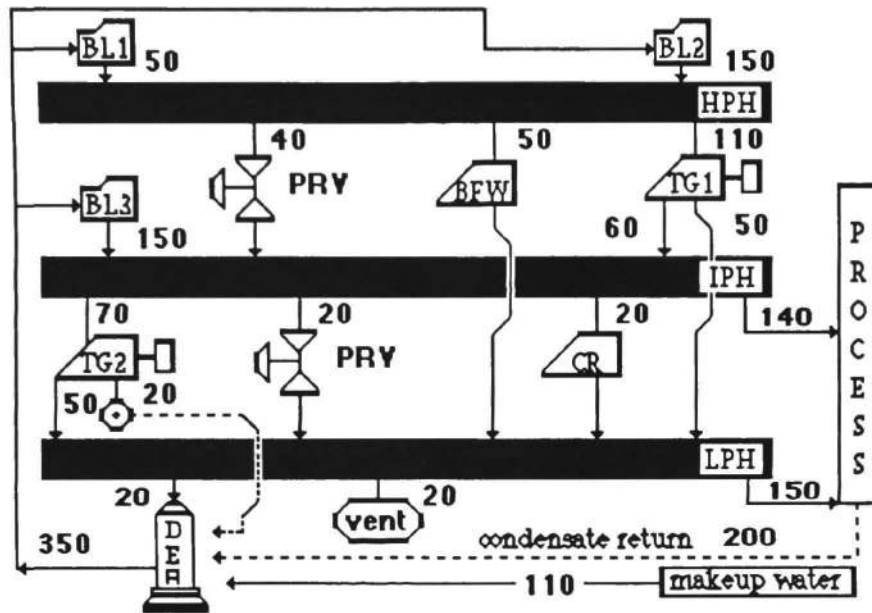

Figure 1