

SEAS: A DUAL MEMORY ARCHITECTURE FOR COMPUTATIONAL COGNITIVE MAPPING

Nestor A. Schmajuk
Center for Adaptive Systems
Department of Mathematics
Boston University

1987

ABSTRACT

We introduce a dual memory architecture that, by way of computing conditioned-conditioned stimulus (CS-CS) associations and conditioned-unconditioned stimulus (CS-US) associations, is capable of **computational cognitive mapping**.

The network is able to describe complex classical conditioning paradigms in which cognitive mapping is presumably involved such as blocking, overshadowing, sensory preconditioning, second-order conditioning, compound conditioning, serial compound conditioning, and sensory preconditioning. By assuming that limbic-cortical regions of the brain are involved in CS-CS associations, the network is able to describe several cognitive impairments that have been reported after limbic-cortical lesions.

INTRODUCTION

Two major approaches characterize the study of the neurobiological basis of memory. One approach considers that memory is a unitary process that involves the whole brain. Another approach regards memory as a multiple process that involves different areas of the brain, each area being involved in a different type of memory (Kesner, 1984). For example, Squire (1982) suggested that hippocampal and amygdalar regions of the brain are participated in the acquisition of new information about the world (declarative memory) but not in the acquisition of new perceptual-motor skills (procedural memory). In the same vein, other authors proposed that the limbic-cortical regions of the brain would be involved in processes such as off-line associations (Hirsh, 1974), stimulus configuration (Mishkin and Petri, 1984), vertical associative memory (Wickelgren, 1979), or representational memory (Thomas and Spafford, 1984). Striatal and cerebellar regions of the brain would be involved in processes such as on-line associations (Hirsh, 1974), habit formation (Mishkin and Petri, 1984), horizontal associative memory (Wickelgren, 1979), or dispositional memory (Thomas and Spafford, 1984).

In line with the approach that regards memory as a multiple process, we have introduced a **dual memory architecture** that, by way of computing conditioned-conditioned stimulus (CS-CS) associations and conditioned-

unconditioned stimulus (CS-US) associations, allows to build **computational cognitive maps** (Schmajuk, 1986a; Schmajuk, 1986b; Schmajuk and Moore, 1986). In the context of the multiple memory process approach, CS-CS associations might be regarded as components of off-line associations, declarative memory, stimulus configuration, vertical associative memory, or representational memory. CS-US associations might be regarded as components of on-line associations, procedural memory, habit formation, horizontal associative memory, or dispositional memory. Limbic-cortical areas would be involved in CS-CS associations, whereas striatal and cerebellar regions would be involved in CS-US associations.

The present paper presents a second-order associative network, designated the SEAS network (as a mnemonic for **SE**cond-order **AS**sociative), and illustrates its behavior in complex classical conditioning paradigms. The SEAS network is able to describe conditioning paradigms such as conditioned inhibition, blocking, overshadowing, sensory preconditioning, second-order conditioning, compound conditioning, serial compound conditioning, and sensory preconditioning. The network is also able to describe some very well known effects of limbic-cortical and striatal-cerebellar lesions.

THE SEAS NETWORK

First-order associations. Consider the case of one CS, CS_i , that predicts event k . Net associative value, V_i^k , represents the first-order prediction of event k by CS_i . When the CS_i is accompanied or followed by event k , the associative value between CS_i and event k , V_i^k , increases by

$$\Delta V_i^k = S_i \beta_i^r \tau_i (\Gamma^k - B^k), [1]$$

where S_i is the salience of CS_i , β_i^r is $\beta_i^r = \theta_i^r$ ($0 < \theta_i^r < 1$) when $\Gamma^k > B^k$, and $\beta_i^r = \theta_i^{r'}$ ($0 < \theta_i^{r'} < \theta_i^r$) when $\Gamma^k < B^k$, τ_i is the trace of CS_i , Γ^k the intensity of event k , and B^k the aggregate prediction of event k .

Second-order associations and cognitive mapping. Consider now the case of two CSs, CS_i and CS_r , that predict event k . It is assumed that CS_i predicts k directly by V_i^k and indirectly by predicting CS_r , by V_i^r . In turn CS_r predicts k by V_r^k . The second-order net prediction of event k by CS_i , is expressed as the product $V_i^r V_r^k$. The product $V_i^r V_r^k$ can express - quantitatively - four logical inferences. For example, if CS_i predicts the absence of CS_r (negative V_i^r), and CS_r predicts the presence of event k (positive V_r^k), CS_i will predict the absence of event k (negative $V_i^r V_r^k$)

B_i^k , the first- and second-order prediction of event k by CS_i , is

$$B_i^k = (V_i^k + \sum_r w_i^r V_i^r V_r^k) \tau_i. [2]$$

V_i^k is the net associative value of CS_i with event k . The sum over the index r involves all CSs with index $r = k$. V_i^r is the net associative value of CS_i with all CSs with index $r = k$. V_i^r is the net associative value of all CS with event k . τ_i is the trace of CS_i . The mathematical expression for τ_i is given below. Coefficient w_i^r serves to adjust the relative weights of first- and second- order predictions in paradigms such as conditioned inhibition. In order to avoid redundant CS_i -US and CS_i - CS_i -US associations, $w_i^r = 0$ when $i = r$, and $w_i^r > 0$ when $i \neq r$. B^k , the aggregate prediction of event k made upon all CSs (including the context) with $\tau > 0$ at a given moment, is

$$B^k = \sum_i B_i^k . \quad [3]$$

Variable B^k participates in the rules governing the computation of V_i^k . In addition, B^k determines the topography of the NM response, as described below.

The integration of different predictions, V_i^r V_r^k , into a larger and new prediction, B_i^k , is similar to the process Tolman (1932) called inference. For Tolman, expectancies can be combined in order to form new expectancies and organized in a "cognitive map". Up to the present, models for classical conditioning did not have any mechanism to account for "inference" processes. The introduction of second-order associations allows to build "computational cognitive maps" in which CS-CS predictions can be combined among them, and with CS-US associations. By the introduction of second-order associations the SEAS model is capable of describing sensory preconditioning and secondary reinforcement.

Figure 1 shows how SEAS explains sensory preconditioning. Sensory preconditioning is predicted by allowing CS_B to be associated to CS_A in a first phase, denoted by the solid circle V_B^A , and CS_A to be associated to the US in a second phase, denoted by the solid circle V_A^{US} . When CS_B is presented alone in a test trial, it activates the A representation through node V_B^A , and this A representation activates the node V_A^{US} , generating a conditioned response (CR).

Trace function. It is assumed that a CS_i generates a trace, τ_i , that increases over time to a maximum, stays at this level for a period of time independent of the CS duration, and then gradually decays back to zero. Formally, trace τ is defined for $t \leq 200$ msec by

$$\tau(t) = CS_{max} (1 - e^{-(k_1 t)}), \quad [4]$$

where CS_{max} is the maximum intensity of the CS and k_1 is a constant, $0 < k_1 < 1$. Parameter k_1 is selected so that the ISI for optimal conditioning is 200 msec.

$\tau(t)$ remains equal to CS_{max} as long as the CS does

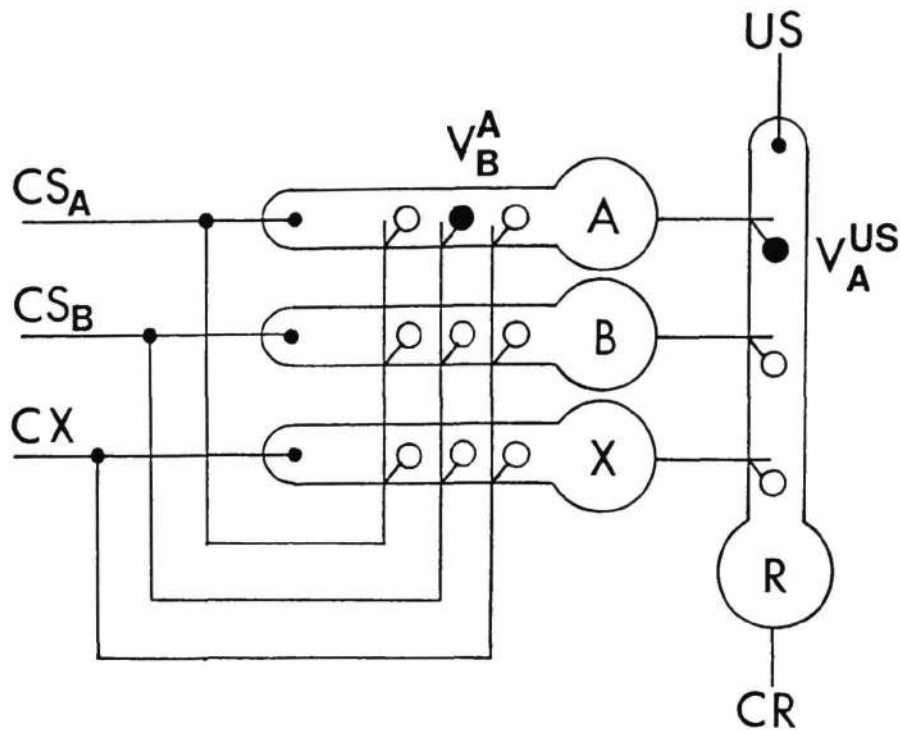

Figure 1. **SEAS neural network.** CSA and CSB : conditioned stimuli . CX: Context. US: unconditioned stimulus. CR: conditioned response. V_A^B : CSA-CSB associative value. V_A^{US} : CSA-US associative value. For explanation see text.

not decay. If the CS = 0 and $t > 200$ msec, $\tau(t)$ decays by

$$\tau(t) = CS_{max} (e^{-(k_1 t)}), \quad [5]$$

If CS_i is not present 200 msec after its onset, the trace decays to zero.

Performance Rules. The SEAS network incorporates performance rules that permit realistic descriptions of rabbit's classically conditioned nictitating membrane (NM) responses in real time (Gormezano, Kehoe, and Marshall,

1983). Performance rules relate variable B_j^{US} to the topography of NM responses.

Time of CR onset is the earliest time t such that

$$\sum_{t'=t_i}^t \sum_j B_j^{US}(t') \geq L1, \quad [6]$$

where t_i denotes the time step at which CS_i onset occurs. The sum over the index j involves B_j^{US} of all CSs with $\tau_j > 0$, excluding the context. Sum over index t involves all time steps for which $\tau_j > 0$, starting at the time step when the amplitude of the NM response as defined by Equation 7 equals zero. $L1$ is a threshold greater than zero. Equation 6 implies that as B_j^{US} increases over trials, CR onset moves progressively to an asymptote determined by $L1$.

During the CS period, for time steps $t > t_i$, the amplitude of the NM response, $NMR(t)$, is changed by

$$\Delta NMR(t) = k2 (B_j^{US}(t) - NMR(t)), \quad [7]$$

where $k2$ is a constant ($0 < k2 < 1$).

During the US period, while $B_j^{US}(t) > \Gamma^{US}(t)$, is given by Equation 7. However, when $B_j^{US}(t) < \Gamma^{US}(t)$, $NMR(t)$ increases by

$$\Delta NMR(t) = k2 (\Gamma^{US}(t) - NMR(t)), \quad [8]$$

When $B_j^{US}(t)$ and $\Gamma^{US}(t)$ equal zero, $NMR(t)$ decays to baseline by

$$\Delta NMR(t) = - k2 NMR(t). \quad [9]$$

Effects of cerebellar lesions. A description of the effect of cerebellar lesions (CL) in agreement with Lincoln, McCormick, and Thompson's (1982) results, is obtained by assuming that lesions of this limbic structure impair CS-US associations but not the computation of CS-CS associations. Mathematically, after CL it is $V_i^{US} = 0$.

Effects of hippocampal lesions. A description of the effect of hippocampal lesions (HL) in agreement with experimental data (see Schmajuk, 1984, for a review) is obtained by assuming that lesions of this limbic structure impair CS-CS associations but not the computation of CS-US associations. Mathematically, after HL it is $V_i^r = 0$.

Impairments in CS-CS associations imply impairment in cognitive mapping. Since $V_i^r = 0$, B_i^k is given by

$$B_i^k = V_i^k \tau_i. \quad [10]$$

Because B_i^k for HL animals computed with Equation 10 is larger than B_i^k for normal animals given by Equation 2, use

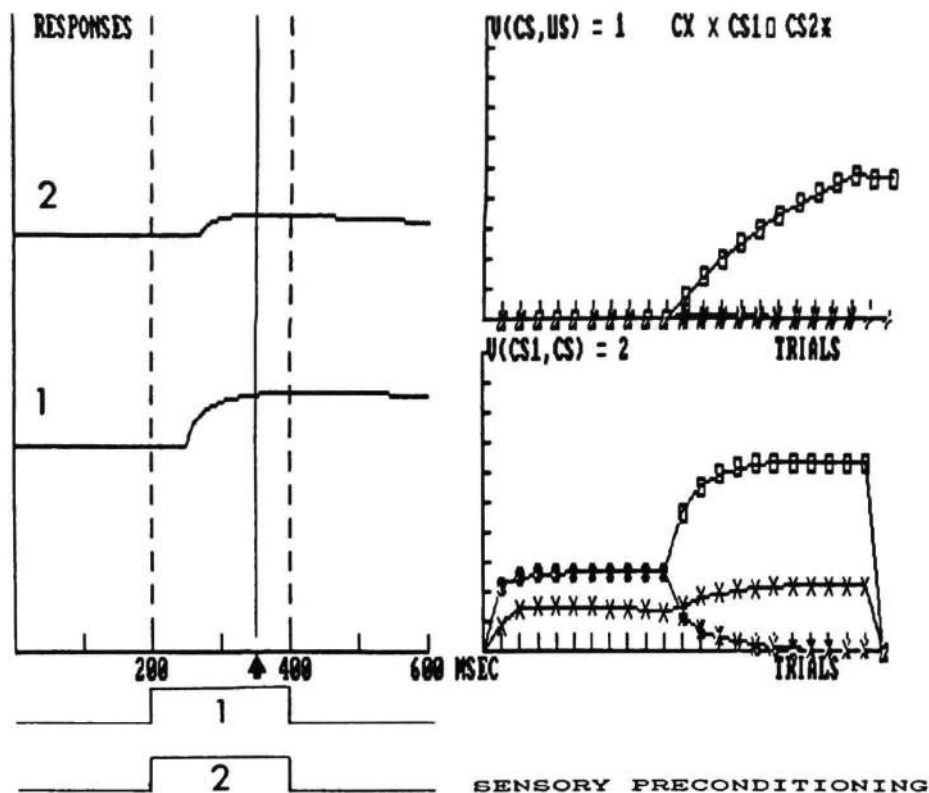

Figure 2. **Sensory preconditioning.** [1] : CS(1). [2] : CS(2). [X] : Context. Left Panels: NM response topography in 1- and 2- trials, after 10 CS(1)-CS(2) nonreinforced trials and 10 CS(1)reinforced trials. Upper-Right Panels: CS-US associative values, $V(CS, US)$, at the end of each trial, as a function of trials. Lower-Right Panels: CS1-CS associative values, $V(CS1, CS)$, at the end of each trial, as a function of trials.

of Equation 10 implies impairments in several classical conditioning paradigms, including blocking and sensory preconditioning.

COMPUTER SIMULATIONS

In the simulations, continuous time was converted to discrete time steps or bins of 10 msec in duration. Each trial consisted of 60 bins. Otherwise specified, the simulations assumed 200 msec CSs, the last 50 msec of which overlaps the US.

Initial values of V_s were zero for all i 's. Parameters values for variations of associative values were : $S_1 = 1$, $S_2 = 1$, $S_x = .1$. $\theta_i^r = 0.3$ and $\theta_i^{r'} = 0.03$ for $r = US$. $\theta_i^r =$

0.015 and $\theta_{ir} = 0.0015$ for $r = US$. For computations of B_i^k : $w_i^k = 2$ when $i \neq r$; and $w_i^k = 0$ when $i = r$. For computations of the NM CR : $L1 = 2$. For computation of the trace: $k1 = 0.1$, and for the NM response topography : $k2 = 0.5$.

Simulation results.

Sensory preconditioning. Figure 2 shows simulations of a sensory preconditioning paradigm. In the first phase, 10 nonreinforced trials with a compound CS(1 and 2). During the second phase, one of the nonreinforced CSs (1) was reinforced for 10 trials. A test trial assessed the CR to CS(2) never paired with the US. Simulations showed that context associability decreases during preconditioning. In the nonreinforced test trial CS(2) acquired inhibitory associative value because it was presented in a context with excitatory associative value. CS(2) generated a CR. Simulation results are in agreement with data reported by Port and Patterson (1984) for normal animals. After HL, CS-CS associations are absent and therefore sensory preconditioning is also absent, a result in agreement with Port and Patterson (1984), who found that fibrial (hippocampal output) lesions in rabbits impaires sensory preconditioning.

Serial Compound Conditioning. Figure 3 shows simulations of a serial compound conditioning paradigm, in which two conditioned stimuli (CS1 and CS2) are followed by the US. The temporal primacy of CS1 over CS2 determines CS1 to become more strongly associated with the US than CS2, in spite of the contiguity of CS2 and the US. As shown in Figure 3, CS1 generates a CR larger than that generated by CS2.

Our results are in agreement with Wickens, et al (1973), who found that, after a CS1-CS2 serial compound had been paired with a US, associations acquired by CS1 and CS2 were functions of the CS1-CS2 interval. With a long CS1-CS2 interval, each CS-US association was inversely proportional the respective CS-US interval, and therefore, the CR generated by CS2 was larger than the CR elicited by CS1. With an intermediate CS1-CS2 interval, as in the case of our simulation, the CR elicited by CS1 was larger than that elicited by CS2. Finally, with a short CS1-CS2 interval, the CR generated by CS2 was larger than that produced by CS1. According to the SEAS model, associations acquired by CS1 and CS2 are functions of the CS1-CS2 interval, because the CS1-CS2 interval establishes the degree of association between CS1 and CS2 (V_i^2 by Equation 1), and this degree of association between CS1 and CS2 controls the associative value of CS1 and CS2 with the US (B_i^k by Equation 2).

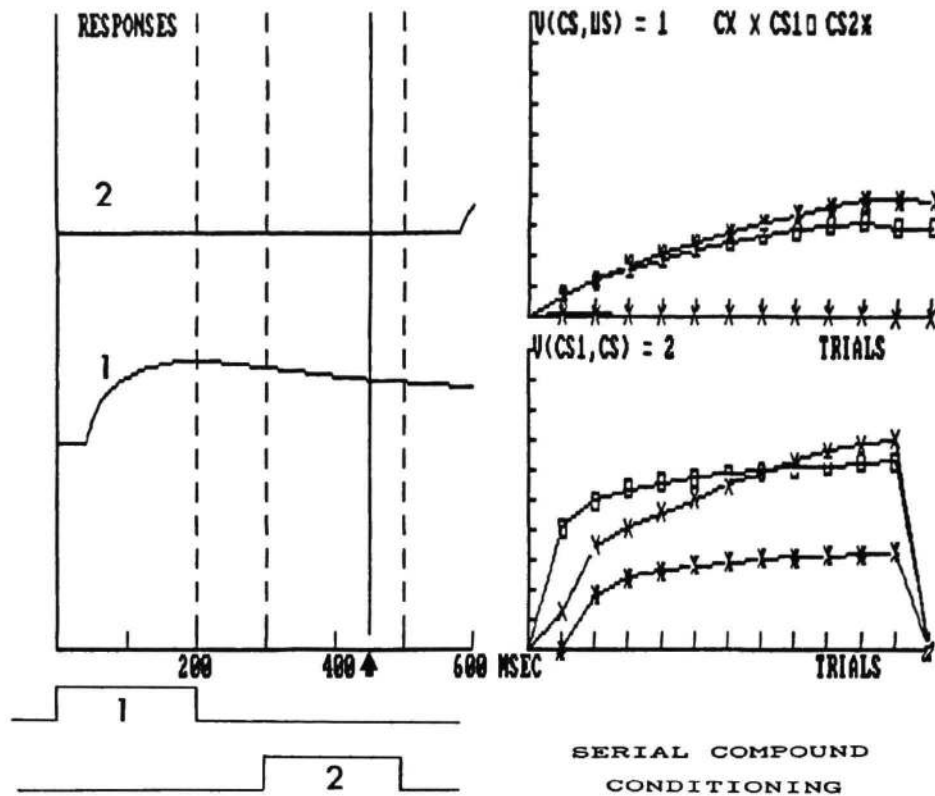

Figure 3. Serial compound conditioning. [1] : CS(1). [2] : CS(2). [X] : Context. Left Panels: NM response topography in 1- and 2- trials, after 10 CS(1)-CS(2) nonreinforced trials and 10 CS(1)reinforced trials. Upper-Right Panels: CS-US associative values, $V(CS,US)$, at the end of each trial, as a function of trials. Lower-Right Panels: CS1-CS associative values, $V(CS1,CS)$, at the end of each trial, as a function of trials.

The SEAS network predicts that serial compound conditioning is impaired after HL, each CS being able to acquire associations inversely proportional to their contiguity with the US. This predictions awaits experimental testing.

Blocking. Figure 4 shows simulations of a blocking paradigm. Experimentals received 10 trials with CS (1) (blocker) paired with the US followed by 10 trials with CS (1) and CS(2) (blocked CS) paired with the US. The network showed simulated blocking in the normal case (N) because the designated blocked CS(2) does not generate a CR. After HL the network predicts that the blocked CS (2) will show a larger CR than it does in the normal case. The results agree with blocking data in the normal rabbit NM response preparation as reported by Marchant and Moore (1973), and in the HL rabbit as reported by Solomon (1977).

DISCUSSION

The present paper introduces SEAS, a dual memory architecture that is capable of generating computational cognitive maps. When applied to classical conditioning, the network describes several complex classical conditioning paradigms in real time.

The SEAS network is able to describe paradigms, such as serial compound conditioning, that had been successfully explained by attentional theories of conditioning (see Kehoe, 1983). This fact points out to a degree of equivalence between attentional approaches and higher-order associative approaches such as that presented here. This equivalence between attentional and higher-order associative approaches might be based on the fact that both are dual memory systems that rely on the existence of a second memory for storing information not immediately connected to open responses, such as CS-US associations.

In addition to the description of normal behavior, the SEAS network can describe some of the effects of cerebellar and hippocampal lesions on the classically conditioned NM response in the rabbit.

This study was supported in part by NSF Grant IST8417756.

REFERENCES

Gormezano, I., Kehoe, E.J., & Marshall, B.S. (1983). Twenty years of classical conditioning research with the rabbit. *Progress in Psychobiology and Physiological Psychology*, 10, 197-275.

Hirsh, R. (1974) The hippocampus and contextual retrieval of information from memory: A theory. *Behavioral Biology*, 12, 421-444.

Kehoe, E.J. (1983). CS-US contiguity and CS intensity in conditioning of the rabbit's nictitating membrane response to serial compound conditioning. *Journal of Experimental Psychology*, 9, 307-319.

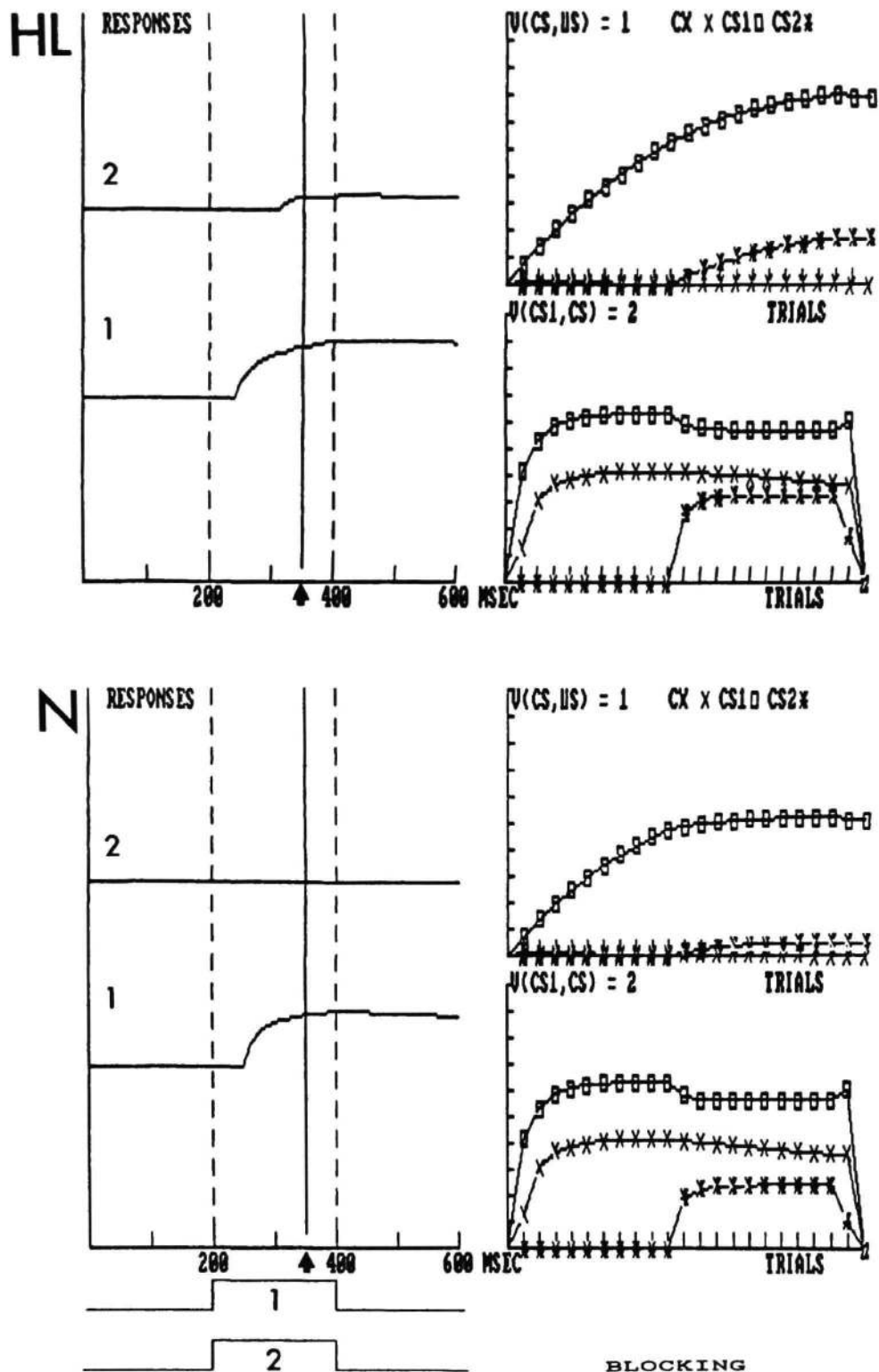

Figure 4. **Blocking.** N: normal case. HL: hippocampal lesioned case. [1] : CS(1). [2] : CS(2). [X] : Context. Left Panels: NM response topography in 1- and 2- test trials after 10 CS(1) reinforced trials and 10 CS(1) and CS(2) reinforced trials. Upper-Right Panels: CS-US associative values, $V(CS,US)$, at the end of each trial, as a function of trials. Lower-Right Panels: CS1-CS associative values, $V(CS1,CS)$, at the end of each trial, as a function of trials.

Kesner, R.P. (1984). The neurobiology of memory: implicit and explicit assumptions. In **"The Neurobiology of Learning and Memory"**, G.Lynch, J.L.McGaugh, and N.M.Weinberger (Eds.), New York: Guilford Press.

Lincoln, J.S., McCormick, D.A., & Thompson, R.F. (1982). Ipsilateral cerebellar lesions prevent learning of the classically conditioned nictitating membrane/eyelid response. **Brain Research**, 242, 190-193.

Marchant, H.G., & Moore, J.W. (1973). Blocking of the rabbit's conditioned nictitating membrane response in Kamin's two-stage paradigm. **Journal of Experimental Psychology**, 101, 155-158.

Mishkin, M., & Petri., H.L. (1984). Memories and habits: Some implications for the analysis of learning and retention. In L.R. Squire and N. Butters (Eds.), **Neuropsychology of Memory**. New York: Guilford Press.

Port, R.L., & Patterson, M.M. (1984). Fimbrial lesions and sensory preconditioning. **Behavioral Neuroscience**, 98, 584-589.

Schmajuk, N.A. (1984). Psychological theories of hippocampal function. **Physiological Psychology**, 12, 13-22.

Schmajuk, N.A. (1986a). Real-time attentional associative models of classical conditioning and the hippocampus. Unpublished Doctoral Dissertation. University of Massachusetts.

Schmajuk, N.A. (1986b). A real-time model for classical conditioning. 19th Annual Meeting of the Society of Mathematical Psychology. Cambridge, Massachusetts.

Schmajuk, N.A., & Moore, J.W. (1985). Real-time attentional models for classical conditioning and the hippocampus. **Physiological Psychology**, 13, 278-290.

Schmajuk, N.A., & Moore, J.W. (1986). A real-time attentional-associative network for classical conditioning of the rabbit's NMR. Proceedings of the 8th Annual Conference of the Cognitive Society, Amherst, Massachusetts.

Solomon, P.R. (1977). Role of the hippocampus in blocking and conditioned inhibition of rabbit's nictitating response. **Journal of Comparative and Physiological Psychology**, 91, 407-417.

Squire, L.R. (1982). The neuropsychology of human memory. **Annual Review of Neuroscience**, 5, 241-273.

Thomas, G.J., & Spafford, P.S. (1984). Deficits for representational memory induced by septal and cortical lesions (Singly and combined) in rats. **Behavioral Neuroscience**, 98, 394-404.

Tolman, E.C. (1932). Cognitive maps in rats and men. **Psychological Review**, 55, 189-208.

Wickelgren, W.A. (1979). Chunking and consolidation: A theoretical synthesis of semantic networks, configuring in conditioning, S-R versus cognitive learning, normal forgetting, the amnesic syndrome, and the hippocampal arousal system. **Psychological Review**, 86, 44-60.

Wickens, D.D., Nield, A.F., Tuber, D.S., & Wickens, C.D. (1973). Stimulus selection as a function of CS1-CS2 interval in compound conditioning of cats. **Journal of Comparative and Physiological Psychology**, 85, 295-303.