

The Context-Sensitive Cognitive Architecture DUAL

Boicho Nikolov Kokinov
Institute of Mathematics
Bulgarian Academy of Sciences
Bl.8, Acad. G. Bonchev Street
Sofia 1113, BULGARIA
kokinov@bgearn.bitnet

Abstract

Context-sensitivity is an important characteristic feature of every cognitive process and therefore should be reflected in every architecture pretending to explain human cognition. In this paper some experimental facts demonstrating context effects on various cognitive processes are reviewed and an attempt at context modeling is described.

A hybrid (symbolic/connectionist) cognitive architecture, DUAL, is proposed. It consists of a multitude of agents having both a symbolic and a connectionist part. The symbolic part represents some knowledge structure, while the connectionist part represents its relevance to the current context. The performance of the cognitive system emerges as result of the work and interaction of the currently active agents, where the set of active agents is not predefined for a specific task but is dynamic and reflects the specific context. So particular symbolic operations and data structures may be supported or suppressed depending on the particular activation pattern of the connectionist parts which represent the context-dependent relevance of the operations and structures. In this way a context-sensitive computation emerges.

An example of context-sensitive deductive reasoning is described.

1. Context-Sensitivity of Human Cognition

There are two phenomena well studied in perception and language understanding: context effects and priming effects.

Context effect is the change in human response caused by changes in the environment (the external context) of the target stimulus, e.g. the change in the success/failure ratio or in the reaction time of recognizing the same letter presented within different words or strings, or without context.

Priming effect is the change in human response to a target task caused by changes in the subjects' preliminary setting (i.e. their internal state), e.g. the change in the success/failure ratio or in the reaction time of recognizing the same target word (e.g. "bread") presented immediately after different "priming" words (e.g. "butter", "knife", or "car").

A common explanation of both effects is proposed in this paper. Both of them are actually due to changes in the context - either in the "external" context or in the "internal" one.

The context-sensitivity of human perception and language processing is a well-known and widely accepted fact and every cognitive model of those processes is trying somehow

to explain it. However, typically researchers tend to regard higher-level cognitive processes, such as memory, decision making, and *especially reasoning*, as encapsulated and context-independent. This is, however, not true. There are a lot of experimental results that provide evidence for the context-sensitive character of human high-level cognition.

1.1. Memory

Quite often we are unable to recall some fact but at some other occasion we spontaneously reproduce it.

An experiment performed by the author (Kokinov, 1989) has demonstrated that the success of retrieving a particular fact depends both on the preliminary setting of the subject, i.e. his or her state of mind (internal context) and on the particular wording of the question (external context).

1.2. Decision Making

People make different decisions and choices depending on the particular context, e.g. it is more likely for someone to buy a quite expensive banana if it is surrounded by even more expensive but worse bananas or if he/she has just decided that pleasure is more important than money.

Tversky and Kahneman (1981) have demonstrated shifts of preferences and choice when the same problem is framed in different ways, and Tversky (1969) has obtained results demonstrating the non-transitivity of human judgments for preference. These results can be explained in terms of differences in the internal or external context.

A series of experiments is currently being performed by the author exploring the role of the context for decision making and similarity judgment.

1.3. Reasoning and Problem Solving

These cognitive processes are most often considered as context-independent. However, our everyday experience shows that it often happens that people succeed in solving a problem but fail at a second attempt at it in another occasion or they find a different solution the next time.

Experiments have also shown that reasoning is context-sensitive. The sensitivity of human reasoning to the subjects' preliminary setting (i.e. their internal state of mind) has been explored by experiments demonstrating priming effects on reasoning (Kokinov, 1990). The same effects have been demonstrated in deductive, inductive and

analogical reasoning as well as the decrease of the priming effect with the course of time.

An experiment exploring the influence of the external context (the subjects' environment) on the reasoning process is currently being performed.

I believe that context-sensitivity is an important characteristic feature of every cognitive process and therefore should be reflected in every architecture pretending to explain human cognition. In this paper an attempt at context modeling is presented the DUAL cognitive architecture is described as well as its ability to explain context and priming effects.

2. Context Modeling

So, what is context? *Context* is considered in this paper as *the particular state of the mind of the cognitive system at an instant of time*. In this way context is regarded as the internal state of the cognitive system rather than as the external state of the world. The context includes the active concepts, facts, rules, procedures and goals of the cognitive system which can be used in the processing of information. There are two sources of activation: *the "external" context* - all the entities in human memory which are activated by currently perceived elements of the environment, and *the "internal" context* - all the entities in human memory which had been active within the preceding state of the mind of the subject. So, for example, in a classroom problem solving task the representation of the teacher, of the problem description and of the other notes on the blackboard as well as of the notes in the notebook could be part of the "external" context, whereas the preceding students' thoughts about the nice weather outside, or about previous solved problems could be part of the "internal" context. Another very important aspect of context (according to our definition) is its *dynamic* nature: context is continuously evolving with the course of time due to changes in the environment or in the internal state of mind of the reasoner. Moreover, most of these changes are not voluntary and are even unconscious (see e.g. the priming effects described in Kokinov, 1989, 1990).

There are two main approaches to context modeling till now: explicit context representation and implicit context representation:

Explicit representation means representation of context by particular formal entities - by partitions in semantic networks (Hendrix, 1979), by objects in logics (McCarthy, 1991), or by logical theories (Giunchiglia, 1993). These treatments of context require an explicit decision to be made about the necessity of changing the context which does not reflect the dynamic nature of context as described above.

Implicit representation means representation of context by graded activation of different facts, concepts and procedures. This is an approach followed by Anderson in ACT* (Anderson, 1983), by Hofstadter in Copycat (Hofstadter & Mitchell, in press) as well as in DUAL. This second approach allows to model the dynamic nature of

context both on the conscious level (when some action rises the activation of a specific entity) and on the unconscious level (when the automatic spreading activation process changes the activations of the memory elements). This approach does not require predefined or constructed context descriptions - context is represented by the pattern of activity distribution over the memory elements.

3. Context Modeling in the DUAL Cognitive Architecture

The general idea is the following. A cognitive system built on the DUAL cognitive architecture consists of a large number of simple and highly interconnected agents, each of which can perform a specific task and/or represents some specific knowledge. For example, an agent may "know" a specific fact or rule, may "know" a specific concept, event or situation (i.e. a set of facts, rules and procedures), or may have the ability to perform a specific action (or a set of specific actions). The agents are connected with each other (some of the links are permanent, others are dynamically created and removed) and every agent exchanges information only with its neighbors. All the DUAL agents act in parallel and produce an emergent behavior (computation) of the whole system. However, at a particular moment only some of the agents are active and only they can contribute to the computation. Moreover, every agent acts at its own rate (in an asynchronous manner) depending on its activation level.

In this way even faced (at the macro level) with the same problem, the cognitive system will behave differently in different contexts as the activity distribution will be different due to the differences in the environment and in the preceding memory state. That is, at different occasions different groups of agents with different activity distribution will act together to perform the computation (Figure 1) and consequently different behavior will emerge.

Both the external and internal contexts are represented in the same way by the distribution of activation over the network of agents. That is why the same mechanisms are used for explaining the context and priming effects.

The effects of the different levels of activation of the agents are both on the availability of the corresponding knowledge structures represented by the agents and on the rate of performing of the actions which the agents are capable of (low activation level will even block their actions). A simple example is the marker-passing process. Although all the agents are capable of local marker-passing (i.e. to pass the received markers to their immediate neighbors over specific links), the actual performance will depend on their activation level, i.e. the rate of marker-passing will be proportional to the activation level, and in particular the agent will stop the markers when its activation level is below certain threshold. Therefore in different contexts (i.e. different activation distribution) the markers started from the same nodes and wandering through the same network will pass along different ways, i.e. different results will be produced.

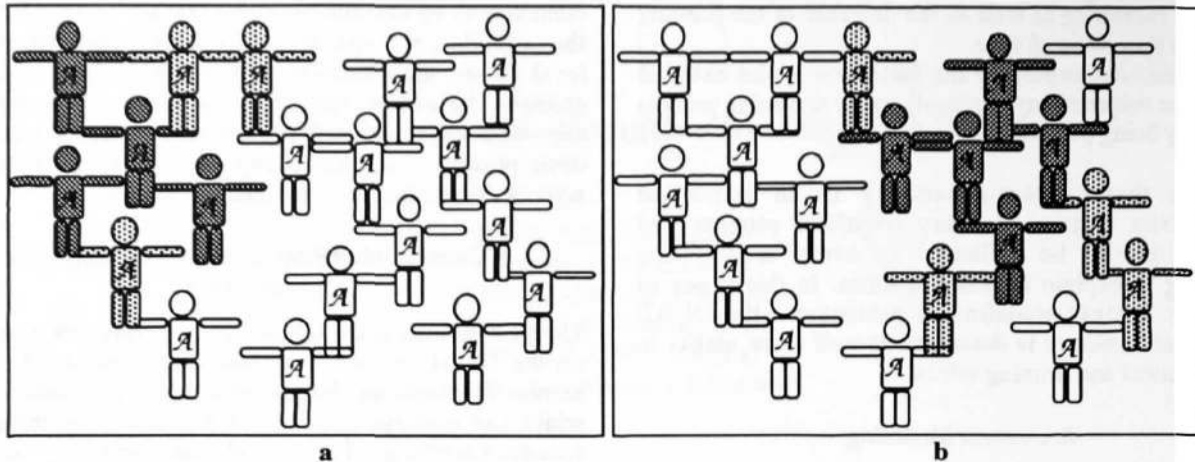

Figure 1.

Different sets of agents are active and perform the computation in different contexts. The filling pattern corresponds to the level of activation of the agent.

4. The architecture of DUAL Agents

The DUAL agents are hybrid: they consist of two parts: L-Brain and R-Brain¹, designed according to the symbolic and connectionist paradigm, respectively. The L-Brain of an agent represents a specific piece of knowledge, while the R-Brain represents the relevance of that knowledge to the particular context. We might think of the R-Brains as energy supplies for the corresponding L-Brains. All the R-Brains work in parallel, but although potentially all the L-Brains can also work in parallel, in each particular moment only a small fraction of them have the necessary energy supplied by the corresponding R-Brains for actual working.

The agents are linked together in a network. Both the agents and the links between them are interpreted differently by the symbolic and connectionist aspects of the architecture.

4.1. Agents as Representational Elements

From the symbolic perspective the agents represent various concepts, objects, events, situations, facts, rules, plans, actions, etc. They might represent static facts as well as built-in procedural knowledge. A frame-like representation scheme is used for several reasons: 1) the integration of declarative and procedural knowledge in common structures, and 2) the possibility to have several different agents (frames) for a single object or concept reflecting different points of view. Details about the representation scheme can be found in (Kokinov, 1989). The slot fillers are simply pointers to other frames or their slots and no special language is used for their description. This leads to a highly distributed representation of the knowledge - even a simple fact is represented by a number of interconnected agents. The links between the agents correspond to these pointers and represent various semantic links.

The connectionist aspect of DUAL is used for representing context. Context is represented in a distributed way by the relevance factors of each agent to the current

¹ this is used as a metaphor and no claims are made about any correspondence to brain structures in humans

situation. The degree of connectivity of each element with all other elements of the current situation is chosen as a particular measure of relevance. This is called associative relevance and is represented by the activation level of the corresponding agent. Thus the activation level of the agent within the connectionist aspect represents the relevance of the knowledge represented by the agent within the symbolic aspect. The links between the agents within the connectionist aspect have no labels and reflect only the strength of the associative relations between them, i.e. how often the two agents appear in the same context. All the semantic links (within the symbolic aspect) are used for spreading activation (within the connectionist aspect), but in addition pure associative links are used by the connectionist aspect which are not used by the symbolic aspect.

The agents corresponding to entities being perceived at the moment as well as agents corresponding to the current goals of the cognitive system are called *source nodes* and they continuously emit activity, i.e. they have a constant level of activation for the period of time they are on the input or goal list. There is a relatively slow decay process so that all currently active nodes can be considered as sources of activation for a period of time. In this way the agents with a high level of activation correspond to descriptions tightly connected both with the external and internal contexts.

4.2. Agents as Processing Units

The R-Brains are simple connectionist processors calculating the activation values and outputs of the nodes on the basis of their input values and current activity. They run in parallel in a discrete synchronous manner in order to simulate the continuous process of spreading activation. They have memory for their previous activation value as well as for all outgoing links (pointers and weights) and a simple numeric processor. It is important that the activation of a node is a function both of the currently received activation from the net and the environment, and of the previous activation level of that node. This makes the influence of the previous memory state (and therefore of the preliminary setting) possible.

The L-Brains are specialized symbolic processors. They have memory for all outgoing links (pointers and labels) as well as for temporary markers (structures containing pointers to other, possibly non-neighboring nodes). All L-Brains have the ability to receive and send markers and to distinguish between links with different labels (e.g. to pass the markers only along links with specific label). In addition, the L-Brains of some agents are able to perform specific hard-wired programs corresponding to some possible actions of the cognitive system. Some examples of such specialized agents are the agents able to initiate a marker-passing process, the agents able to construct new agents (node constructors), the agents able to initiate a mapping between two descriptions, the agents able to establish local correspondence between two structures, etc.

5. An Example of Context-Sensitive Computation Performed by DUAL

The particular example to be considered is from the domain of algebraic transformations. We are not specially interested in that area, but it has been chosen because of two reasons - first, it presents a typical deductive reasoning process, and second, there are some experimental results obtained on the same example (Kokinov, 1990). So, this will be a demonstration of context-sensitive deductive reasoning modeled by the DUAL architecture.

Let's have the following rules represented in the memory of the system, each rule represented by a DUAL agent:

- R1: If the equation contains radicals then square both sides.
- R2: If the expression contains a subexpression of the type $(a - b)^2$ then substitute $a^2 + b^2 - 2ab$ for it.
- R3: If the expression contains a subexpression of the type $(a + b)^2$ then substitute $a^2 + b^2 + 2ab$ for it.
- R4: If the expression contains a subexpression of the type $(a + b) \cdot (a - b)$ then substitute $a^2 - b^2$ for it.
- R5: If an expression contains radicals then try to represent the subradical expressions as exact squares.
- R6: If an expression contains a subexpression of the type $\sqrt{x^2 y}$ and $x > 0$ then substitute $x\sqrt{y}$ for it.
- R7: If you want to represent an expression of type $2ab + t$ as an exact square then try to represent $t = a^2 + b^2$.
- R8: If the expression contains a subexpression of the type $\sqrt{x^2}$ and $x > 0$ then substitute x for it.
- R9: If possible then calculate and reduce the expression.

In addition, there are DUAL agents capable of mapping two descriptions, transferring elements from one description to the other, etc.

Let's consider the representation of the following simple equation $\sqrt{x} - \sqrt{y} = 2$ by DUAL agents (Figure 2). Each agent corresponds to a frame representing a domain relation (e.g. =) or domain operation applied on one or two arguments (e.g. +, -, $\sqrt{\quad}$), or to a symbolic operation on frames (e.g. \leftrightarrow - mapping one frame over another). Agents who touch each other in Figure 2 are connected by semantic links. The associative links (used only for spreading

activation) between agents are represented by arrows in the figure. The symbols depicted at the head of each agent give an idea of the relation, rule, or procedure represented by this agent (e.g. the agent marked by "-" represents the arithmetic operation subtraction applied on two arguments, the agent marked by " $\sqrt{\quad}$ " - the square root operation applied on a single argument, the agent marked by "R1" represents the rule R1, and the agent marked by " \leftrightarrow " - the symbolic operation mapping between frame structures). Agents with numbers on their body represent particular instances of the corresponding concept, whereas agents without numbers the generic concepts themselves. The filling patterns in the agents' legs correspond to their level of activation.

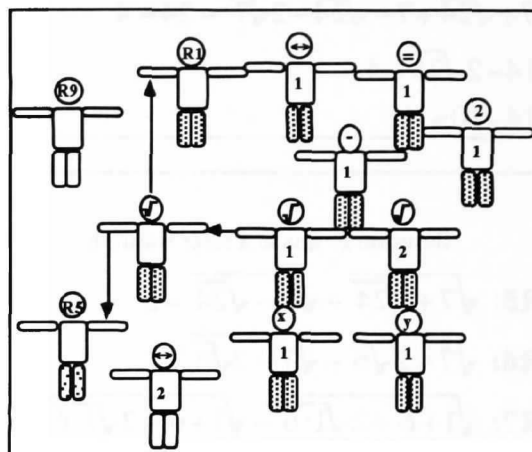

Figure 2. A simplified representation of the equation $\sqrt{x} - \sqrt{y} = 2$ and some of the knowledge structures and processes taking part in its solution.

Let's now consider the following problem: Prove the identity:

$$\sqrt{7 + \sqrt{24}} - \sqrt{7 - \sqrt{24}} = 2$$

Starting with a problem description analogous to the one in the figure the problem solving process runs as follows. Activation spreads over the network of agents with the agents in the problem description being sources of activation. (Possibly some externally activated agents corresponding to perceived objects like notes on the blackboard might also be sources of activation). Some generic concepts (like $\sqrt{\quad}$ "radicals") become activated as well as some of the rules (e.g. R1 and R5). However, since different links have different weights some rules become more active than others (in this example R1 is more active because it is the most typical rule used with radicals). A mapping agent is activated and it establishes a correspondence between the frame representing the most active rule and the frame representing the problem description, and eventually a transfer agent is activated which applies the rule and a new problem description is being established.

Depending on which agents are active when the problem is given to the system (i.e. depending on its preliminary setting) different computations will be performed and

different solutions will be found. Two particular solutions are given below.

Solution 1: this is the more typical solution

$$\sqrt{7 + \sqrt{24}} - \sqrt{7 - \sqrt{24}} = 2$$

R1: $(\sqrt{7 + \sqrt{24}} - \sqrt{7 - \sqrt{24}})^2 = 2^2$

R2: $7 + \sqrt{24} + 7 - \sqrt{24} - 2\sqrt{(7 + \sqrt{24}) \cdot (7 - \sqrt{24})} = 4$

R4: $7 + \sqrt{24} + 7 - \sqrt{24} - 2\sqrt{7^2 - 24} = 4$

R9: $14 - 2\sqrt{25} = 4$

R9: $14 - 10 = 4$

Solution 2: this is a rarer solution

R5: $\sqrt{7 + \sqrt{24}} - \sqrt{7 - \sqrt{24}} = 2$

R6: $\sqrt{7 + 2\sqrt{6}} - \sqrt{7 - 2\sqrt{6}} = 2$

R7: $\sqrt{1 + 6 + 2\sqrt{1 \cdot 6}} - \sqrt{1 + 6 - 2\sqrt{1 \cdot 6}} = 2$

R3 + R4: $\sqrt{(1 + \sqrt{6})^2} - \sqrt{(1 - \sqrt{6})^2} = 2$

R8: $1 + \sqrt{6} - (\sqrt{6} - 1) = 2$

This corresponds to the data obtained in a psychological experiment (Kokinov, 1990) where depending on the different preliminary setting of the subjects these two different solutions of the problem have been produced. The first one is dominating (78%), but the second one appears also at some occasions (7%). The situation changes radically when the rule R5 has been primed the first solution has been produced in considerable less cases (29%), while the second one has been produced by the majority of the subjects (61%). In both cases there are about 10-15% of the subjects who have not been able to solve the problem at all. This corresponds to the case when the appropriate rules have not been activated and attempts are made to apply active but inappropriate rules.

6. Conclusions

There are a number of hybrid systems developed so far (e.g. Hendler, 1989; 1991; Lange & Dyer, 1989; Lange, 1992; Sun & Bookman, 1992), however, they typically consist of two or more modules each of which is developed according to one of the two paradigms - connectionism and symbolism - and the work of each module is more or less independent of the other - only the results are being exchanged between the modules. DUAL is a hybrid system at the micro level

rather than at the macro level - it consists of hybrid micro-agents and so both aspects of the architecture take part in every stage of every cognitive process. The behavior of each agent and its contribution to a particular computation depends both its connectionist and symbolic processing. In this way both aspects are highly integrated.

This architecture provides a platform for building context-sensitive models of cognitive process. A model of context-sensitive similarity judgement is described in (Kokinov, 1992), and a model of context-sensitive analogical reasoning is described in (Kokinov, in press). Work is being done on modeling plan-recognition and decision-making.

In contrast with (McCarthy, 1991) and (Giunchiglia, 1993) DUAL models dynamically the context reflecting its continuous changes. The approach is more similar to the ones of Anderson (1983), French (1991), and Hofstadter and Mitchell (in press). They, however, separate the declarative knowledge (Semantic net & Slipnet) from the procedural knowledge (Rules & Codelets) using different mechanisms for controlling them (in particular these architectures cannot explain the priming effects on rule usage demonstrated in Kokinov, 1990). Using hybrid agents and frame-like representation DUAL allows an uniform treatment of both types of knowledge explaining contextual effects in both cases by the same mechanisms. Both Anderson and Hofstadter & Mitchell consider only static environments reduced to the problem elements ignoring the dynamic changes in the real-world environment. Hofstadter & Mitchell consider in addition some stochastic factors which compensate for the lack of resting internal state of the system when starting a new problem solving task, but they cannot explain the priming effects on problem solving in this way. However, these models have a lot of other features making them superior to DUAL like the learning mechanisms of ACT* and the perceptual mechanisms of Copycat.

Acknowledgements

This research has been partially supported by the Bulgarian National Science Fund.

References

- Anderson, J. (1983). *The Architecture of Cognition*, Cambridge, MA: Harvard Univ. Press.
- French, B. (1991). *Tabletop*. PhD Thesis. Univ. of Michigan.
- Giunchiglia, F. (1993). Contextual Reasoning. In: *Epistemologia - Special Issue on I Linguaggi e le Machine*, 16, 345-364.
- Hendler, J. (1989). Marker-passing over Microfeatures: Towards a Hybrid Symbolic/Connectionist Model. *Cognitive Science*, 13, 79-106.
- Hendler, J. (1991). Developing Hybrid Symbolic/Connectionist Models. In: Barnden, J. & Pollack, J. *High-Level Connectionist Models, Advances in Connectionist and Neural Computation Theory*, vol. 2, Norwood, NJ: Ablex Publ. Corp.

- Hendrix (1979). Encoding Knowledge in Partitioned Networks. In: Findler (ed.) *Associative Networks*. New York: Academic Press.
- Hofstadter, D. & Mitchell, M. (in press). The Copycat Project: A Model of Mental Fluidity and Analogy-Making. In: Holyoak, K. & Barnden, J. (eds.) *Analogical Connections, Advances in Connectionist and Neural Computation Theory*, vol. 2, Norwood, NJ: Ablex Publ. Corp.
- Kokinov, B. (1989). About Modeling Some Aspects of Human Memory. In: Klix, Streitz, Waern, Wandke (eds.) *MACINTER II*, Amsterdam: North-Holland.
- Kokinov, B. (1990). Associative Memory-Based Reasoning: Some Experimental Results. In: *Proceedings of the 12th Annual Conference of the Cognitive Science Society*, Hillsdale, NJ: Lawrence Erlbaum Associates.
- Kokinov, B. (1992). Similarity in Analogical Reasoning. In: B. du Boulay & V. Sgurev (eds.) *Artificial Intelligence V*. Amsterdam: Elsevier.
- Kokinov, B. (in press). A Hybrid Model of Reasoning by Analogy. In: Holyoak, K. & Barnden, J. (eds.) *Analogical Connections, Advances in Connectionist and Neural Computation Theory*, vol. 2, Norwood, NJ: Ablex Publ. Corp.
- Lange, T. (1992). Hybrid Connectionist Models: Temporary Bridges Over the Gap between the Symbolic and the Subsymbolic. In: Dinsmore, J. (ed.) *The Symbolic and Connectionist Paradigms: Closing the Gap*. Hillsdale, NJ: Lawrence Erlbaum Associates.
- Lange, T., & Dyer, M. (1989) High-Level Inferencing in a Connectionist Network. *Connection Science*, 1, 181-217.
- McCarthy, J. (1991). Notes on Formalizing Context. unpublished, 1991.
- Sun, R. & Bookman, L. (1992). *Integrating Neural and Symbolic Processes: The Cognitive Dimension*. AAAI Press.
- Tversky, A., & Kahneman, D. (1981). The Framing of Decisions and the Psychology of Choice. *Science*, vol. 211, pp. 453-458.
- Tversky, A. (1969). Intransitivity of Preferences. *Psych. Review*, vol 76, pp. 31-48.