

Working Memory Retention Span in the Invisible Displacement Task in Horses

Ida Ilmer

Doctoral School in the Social Sciences,
Rynek Główny, 34, 2 p., 31-010 Kraków, Poland
ida.ilmer@doctoral.uj.edu.pl

Tomasz Smoleń

Centre for Cognitive Science, Jagiellonian University,
ul. Ingardena 3, 30-060 Kraków, Poland
tomasz.smolen@uj.edu.pl

Abstract

Working memory is vital for complex tasks but is under-explored in non-human species, such as horses. This study evaluates horse working memory through an invisible displacement task involving delayed choices. Twenty-six horses were tasked with selecting between two buckets containing a treat, with delay intervals of 10, 30, or 45 seconds between presentation and decision-making. The accuracy of correct choices was influenced by delay duration, presence of distracting stimuli, and performance in basic condition. Results showed that horses could retain information for up to 30 seconds and process information about object displacement. These findings enhance our understanding of horse cognition, revealing their capacity for simple reasoning and a longer working memory span than previously acknowledged.

Keywords: horses; working memory; displacement task; transposition test

Introduction

Working memory (WM) plays a crucial role in virtually all complex cognitive activities. Its importance has been widely established in numerous studies on humans, including its key connections with executive functions (Nee et al., 2013), attention control (Engle, 2002), language comprehension (Daneman & Merikle, 1996), and fluid intelligence (Chuderski et al., 2012). However, little is known about the functioning of WM in species other than humans and other primates. Sparse research in this area includes studies on species such as pigeons (Diekamp et al., 2002) and mice (Light et al., 2010) or broad theoretical analyses (Earl, 2023). Nevertheless, it has been shown that both in humans and animals, the functioning of selective attention, as well as the capacity and retention of working memory, are crucial for overall cognitive abilities (Matzel & Kolata, 2010).

Recent studies reveal that horses are able to perform complex cognitive tasks (Evans et al., 2024). These include using symbols to interact with humans (Mejdell et al., 2016), solving problems through conceptual understanding (Hanggi, 2003) and cross-modal recognition (Lampe & Andre, 2012; Proops et al., 2009; Proops & McComb, 2012). Horses have demonstrated the ability to adjust their decision-making strategies after failure (Lovrovich et al., 2015), may possess elementary numerical competencies related to spontaneous

quantity assessment (Uller & Lewis, 2009) and are capable of utilizing local cues from humans, facilitated through joint attention (Rørvang et al., 2018; Wathan & McComb, 2014).

Working Memory

The existence of these skills raises questions about the most fundamental cognitive abilities in horses that underlie them. Although it is virtually impossible to identify a definitive set of capacities that determine an animal's general cognitive ability, working memory and executive control efficiency appear to be a good starting point (Constantinidis & Klingberg, 2016; Gruszka & Nęcka, 2017; Unsworth et al., 2015).

There are significant differences in WM retention span and capacity across different animal species: dogs are capable of maintaining object representation for up to 240 seconds (Fiset et al., 2003); in cats, the ability to locate a hidden object within 30 seconds of its presentation is minimal, but their performance significantly improves with 60-second delays (Fiset & Doré, 2006). Rats typically succeed in tasks with a 60-second delay (though, as in humans, retention declines with age; Bizon et al., 2012; Means & Kennard, 1991; Beatty & Shavalia, 1980). Capuchin monkeys, on the other hand, were able to successfully perform a matching task after both 120-second and 10-minute delays (Tavares & Tomaz, 2002, although it is argued that the retention span was overestimated in this study because the monkeys could rely on the familiarity of the stimuli rather than necessarily engage the working memory, Basile & Hampton, 2013). Drawing firm conclusions about systematic differences in working memory span across species is challenging due to varied methodologies among tasks. However, it is clear that there are significant differences in working memory capacity among the species that have been studied. The considerable interspecies differences may arise from the specific characteristics of the species being studied, whose perceptual and cognitive abilities are adapted to their functioning style and environment (Doré et al., 1996; Lind et al., 2015; Earl, 2023).

The results regarding WM capacity and retention span in horses are not only limited but also contradictory. Some studies suggest that horses can maintain information in WM for

up to 20 seconds (Valençon et al., 2013) or even 30 seconds (Baragli et al., 2011), while others indicate that horses are unable to store information in WM for even 10 seconds (McLean, 2004). These discrepancies may be attributed to several factors, including differences in experimental design (Hanggi, 2010). This situation is somewhat analogous to findings in humans, where working memory can depend on both momentary and lasting factors, such as stress level (Valençon et al., 2013) or age (Cellai et al., 2024). Additionally, there may be other determinants of WM that are specific to this species or, at least, difficult to generalize to other animals. Rochais et al. (2022) found that the type of work performed by horses influenced their memory function, while age, sex, and breed did not. They reported that riding school horses performed better in attention and memory tests than other horses, including sport horses. These findings are supported by observations that the type of training influences horses' attentional engagement (Hausberger et al., 2019).

Displacement Reasoning

The study of WM in humans has consistently demonstrated that it can only be effectively assessed through tasks that demand both the storage and processing of information. This requirement stems from the understanding that working memory relies on a shared attentional capacity to manage these dual functions simultaneously. In contrast, tasks that involve only storage, without engaging processing demands, risk overlooking the multifaceted nature of working memory (see, Rhodes et al., 2018).

So our goal was to present horses with a task which engage an elementary cognitive skill which requires maintaining some informations in the WM and simultaneously using the information for simple reasoning. A task that meets the above criteria and at the same time is relatively uncomplicated, which has been confirmed by its successful use in examining children at an early stage of cognitive development, is the test of the object permanence (Sophian, 1985). Object permanence, as one of the fundamental features of physical cognition, is the ability to reason about hidden objects and to mentally reconstruct their invisible displacement (Jaakkola et al., 2014). Displacement reasoning in simple object permanence tasks is an instance of an activity which in certain circumstances may require active processing of information stored in WM.

One of the research paradigms employed in this area is the transposition task, in which the subject observes an object being placed into one container, which is then swapped with an empty container or displaced (Doré et al., 1996; Barth and Call, 2006; Hoffmann et al., 2011; Auersperg et al., 2014; Nawroth et al., 2015). Solving that type of task is considered to involve basic reasoning, as it requires mentally reconstructing the unseen displacement of the object, thereby involving secondary representations (Jaakkola, 2014). Object permanence was first studied in children by Piaget (1954), who outlined six developmental stages. Initially, children do

not search for hidden objects. By the third stage, they seek partially hidden ones, progressing to retrieving fully hidden items but sometimes erring by looking at old hiding spots in the stage 4. In the fifth stage, they consistently find objects at the correct location, and by the final stage, they can mentally track objects even when hidden (Dore & Dumas, 1987). Stages 1-5 involve understanding visible displacements, while only the stage 6 involves grasping invisible displacements.

Previous studies have demonstrated that certain animal species are capable of maintaining an object representation in the context of invisible displacement, including primates (Barth & Call, 2006), pigeons (Zentall & Raley, 2019), corvids (Hoffmann et al., 2011), goats (Nawroth et al., 2015), and psittacids (Auersperg et al., 2014). However, despite theoretical evidence and prior success in visible displacement tasks even with delayed choice, horses have not yet been able to achieve success in invisible displacement task (Trösch et al., 2020, Rørvang et al., 2021).

Conclusions and Hypotheses

Working memory is essential for many cognitive processes and has been widely studied in humans, but much less is known about its function in non-human species, including horses. While horses have demonstrated advanced cognitive skills like problem-solving, symbol use, and numerical assessment, research on their WM capacity has yielded inconsistent results, with retention estimates ranging from 10 to 30 seconds. These discrepancies may stem from differences in experimental design, task-specific factors, and individual variations influenced by training or environment.

To explore WM in horses further, we aim to use object permanence tests, that require both the storage and processing of information. We hypothesize that horses will be able to store information in working memory (WM) and use it to solve a basic reasoning task. Additionally, we expect that task accuracy will decrease as the duration for holding information in memory increases.

Method

The university ethics committee approved the experimental plan (221.0042.23_2024). Additionally, all horse owners provided written consent for their horses to participate in the study.

Subjects

Twenty six healthy horses from the same stable were included in the study (15 geldings and 11 mares, mean age = 11.5, range = [4, 26]). Twenty of the horses were stabled, while six were free-ranged. Fourteen horses were primarily owned or used by a single person, while twelve were used in a riding school.

Apparatus

The test horses were housed in 3×3-meter stalls, where stabled horses typically stayed overnight, and free-ranged horses frequently spent time during the day for grooming and veterinary care. To facilitate quick and easy repositioning of the buckets during the experiment, a custom apparatus was designed (Figure 1). This device consisted of a two-wheeled wheelbarrow filled with hay, on top of which an adjustable wooden platform was mounted, allowing the bucket height to be tailored to the individual test horse. Two black feeding buckets, familiar to the test horses, were placed on the platform and secured to the wheelbarrow with ropes to minimize movement.

Carrots were selected as treats due to their relatively low odor, minimal risk of provoking allergic reactions, low likelihood of causing digestive issues even with higher intake, and, last but not least, the general preference of horses for this type of reward. Considering the high olfactory sensitivity of horses, specific measures were taken to reduce potential olfactory cues. These included leaving traces of barley dust in the buckets, placing good-quality hay in the wheelbarrow, and positioning additional carrot pieces between the buckets and the experimenter to serve as distractions.

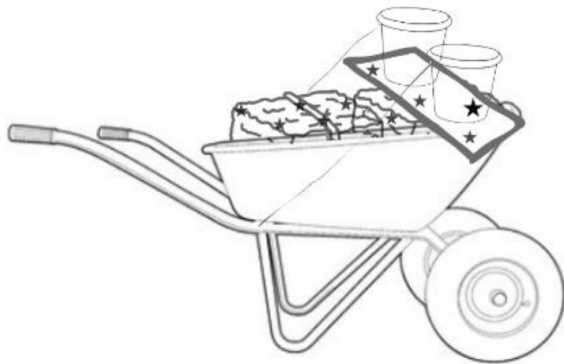

Figure 1: The device used to provide the experimental setup to the horses. The large star (black) represents one of two possible locations of the treat. The small stars (gray) represent the locations of olfactory background distraction carrots.

Procedure

The objective of the experiment was to determine whether the horse could identify which of two buckets contained the treat. This study sought to evaluate horses' working memory retention under varying time intervals and their ability to perform reasoning related to invisible displacement of the treat and maintain a mental representation of the reasoning's outcome.

The general procedural scheme began with placing the apparatus approximately 1.5 meters from the stall door. The experiment commenced by presenting a treat to the horse and subsequently placing it in one of two identical, black buckets (in the test trials, the buckets were then immediately swapped). The chosen bucket was randomized to prevent procedural learning and potential bias in the horse's decision-making process (Gabor & Gerken, 2010). To control for side bias, the final position of the reward (left vs. right bucket) was counterbalanced across trials. Each side was chosen equally often in a pseudo-randomised order, avoiding predictable alternation patterns. Additionally, rigorous precautions were taken to ensure that the experimenter provided no non-verbal cues about the treat's location throughout the experiment (Lovrovich et al., 2015). Following a delay corresponding to the assigned time condition (or immediately in the training phase), the apparatus was moved close to the stall door, enabling the horse to select the bucket it believed contained the treat and consume it. For data reliability, only the horse's initial response was recorded and analysed. This meant that when the apparatus was moved toward the horse's head, the animal could explore only one bucket. Exploration began when the horse oriented its head toward the selected bucket. Regardless of whether the choice was correct or incorrect, the apparatus was withdrawn after the exploration of the chosen bucket was completed. If the horse changed its mind—initially directing its head toward one bucket and then attempting to explore the other—only the first decision was recorded as the trial outcome. All behavioural coding was conducted by a single trained observer using a detailed coding manual developed during pilot testing. While inter-observer reliability was not assessed in this study, the coding protocol was designed to minimise subjectivity.

Training Phase Before the experimental phase, each horse underwent training phase where it made immediate decisions regarding the treat's location.

At the beginning, it was confirmed that the horse's species-specific needs were met, it had not participated in other training activities that day, and it exhibited no signs of physical or mental discomfort.

Initially, the treat was placed twice in each of the buckets. After the animal understood the association between experimenter's action and localization of the treat, the method of bucket selection was changed so that the treat was alternately placed in the buckets. In the third training phase, the treats were placed twice in one bucket and then once in the other bucket. Once each horse achieved 100% accuracy in all three phases of training, the experimental phase began.

Experimental Phase Each horse participated in three experimental conditions, where the variable was the delay (10, 30, or 45 seconds) between the experimenter's action and the horse's chance to choose a bucket. To ensure balanced proportion of each possible conditions order, the sample was ran

domly divided into six approximately equal subgroups, each representing a distinct combination of experimental conditions. Each experimental condition was recorded for further analyses and consisted of three control trials and one test trial. In total, each horse took part in 12 trials (not including the number of trials in the training phase).

In the control trials, no additional manipulations were introduced, and success depended on the horse's ability to recall the treat's location after a set time interval. In the test trials, the empty bucket and the one containing the treat were immediately swapped after placing the treat. Success required the horse to perform and recall the outcome of displacement reasoning after a specified time interval. Failure in the control trials was not interpreted as a lack of understanding of the procedure, given the prior requirement of 100% success during training. Instead, the result was interpreted as the horse's inability to retain the consequences of the displacement due to the time delay.

Although the study was conducted during specific times of the day when the horses typically rested and no additional people were present in the stable area, the animals were sometimes distracted by external stimuli. The most common distractions were auditory, such as passing vehicles, neighing horses, low-flying airplanes, and other unexpected sounds. Some visual stimuli also contributed to distractions, including the sudden appearance of another animal (horse, cat, or dog) within the horse's field of view or the presence of a person.

Statistical analysis

The generalized mixed model was fitted to the data. The response variable was success in finding the treat. The independent variables included time delay, farming type (free-range or stable), type of work (privately owned or used in a riding school), and the presence of auditory distractions during the trial. We also included covariates such as the order of conditions and performance in the control/training condition (number of successes). The model incorporated random effects to account for the within-subject experimental design, with random intercepts specified for individual horses. The selection of random effects was guided by an analysis of the variance components. We compared the variance attributable to potential random effects with the residual variance.

In the second step we fitted similar generalized mixed model but instead of making the performance in control condition a covariate, we used the condition (control vs experimental) a predictor and included the number of successes in any of these condition as a dependent variable.

Statistical significance was set at $\alpha = .05$. all analyses were conducted in R (version 4.4.1; R Core Team, 2024) and lme4 package (Bates et al., 2015).

Results

The horses managed to choose the bucket containing treats in .77 of the trials. The influence of time delay and several other

predictor variables on success in finding the treats appeared to be statistically significant. Table 1 presents analysis of deviance based on the generalized mixed model.

Table 1: Analysis of Deviance Table (Type II Wald χ^2 tests).

Predictor	χ^2	df	p
Time delay	8.898	1	.003 **
Farming type	0.002	1	.960
Work type	0.26	1	.610
Distractions	12.17	1	< .001 ***
Order	3.273	1	.070
Training performance	7.509	1	.006 **

** $p < .01$, *** $p < .001$

We observed that the larger the time delay the lower the probability of success (see below for more detailed analysis), that the auditory distractions presence significantly reduced the horses' performance (from .99 to .54, the distractions appeared in 35% of the trials), and that horses who performed better in training also performed better in the main task.

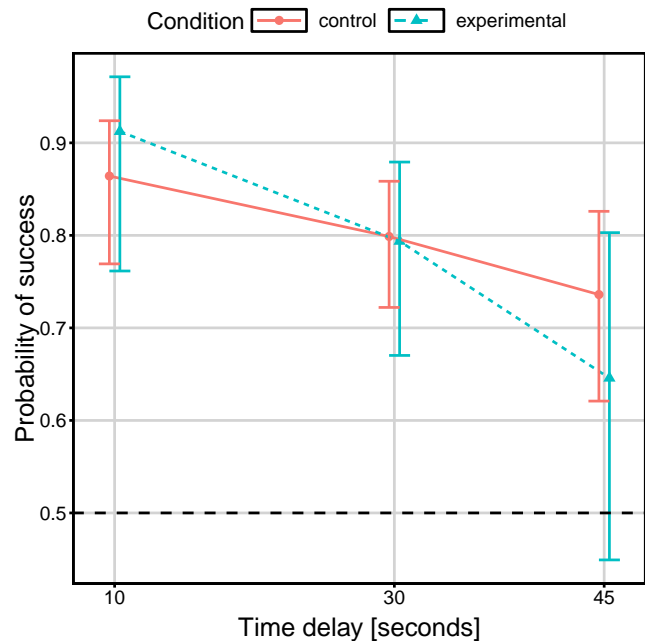

Figure 2: The marginal probability of finding the treats depending on the time delay of the finding stage of the task. The Vertical lines represent 95% confidence intervals. The dashed line represents the random guessing level.

The analysis including the condition and time delay revealed that the longer the time interval the lower the horses' accuracy in finding the treats ($\chi^2[1] = 7.9, p = .005$). There was no main effect of the condition ($\chi^2[1] = 0.086, p = .77$) and the interaction between time delay and condition ap-

peared not to be a significant predictor of the accuracy ($\chi^2[1] = 1.1, p = .29$). However the time delay was not entirely independent from the condition in the influence on the accuracy: In the longest time delay trials (45 seconds) the accuracy was not significantly different from random guessing level (.5) in the experimental condition (mean = .64, 95% CI = [.45, .8]) but it was significantly above guessing level in the control condition (mean = .74, 95% CI = [.62, .82]). Accuracy was above random guessing level in all remaining trials (see Figure 2).

Discussion

The obtained results partially support previous findings suggesting that the WM retention span in horses can reach up to 30 seconds (Baragli et al., 2011). However, when performing simple reasoning concerning displacement was not required, horses were able to retain information for up to 45 seconds, indicating a longer WM retention span under certain conditions. Furthermore, the findings broaden our understanding of equine cognitive abilities by demonstrating that horses are not only capable of simple reasoning in the context of invisible displacement but can also maintain a representation of the outcome of this reasoning for up to 30 seconds.

Achieving this level of cognitive development, allowing for object permanence in invisible displacement tasks, represents a novel finding, contrary to previous research (Trösch et al., 2020). By adding a delay before allowing decision-making, the transposition task was significantly more challenging, yet most horses successfully located the treat under the 10- and 30-second conditions. This discovery raises the hypothesis that domestic horses may possess a form of prospective memory, potentially enabling at least rudimentary planning of future actions. Given that horses frequently undergo training within the context of human interaction, this knowledge could enhance training methods and improve the safety of individuals working with these animals.

The use of positive reinforcement in the experimental procedure raises potential concerns about whether horses could have been influenced by the scent of the treats when making decisions. However, distraction methods applied during the procedure resulted in 23% of experimental trials and 22% of control trials ending in failure. If horses were solely relying on olfactory cues, the failure rate in the experiment would likely have been much lower, and the horses would not have required prior training to comprehend the task.

The comparison between control and experimental trials yields mixed results. Although no statistically significant difference was found regarding the effect of time delay on accuracy between the two conditions, horses in the control condition performed better across all time delays, including the longest 45-second delay. In contrast, within the experimental condition, horses exceeded random guessing accuracy only at the 10-second and 30-second time delays,

while their mean accuracy at the 45-second was not statistically different from guessing level. So, with some caution, it can be assumed that in simple tasks requiring only the recall of treat locations, horses' WM retention may extend to 45 seconds. The reduced success rate in test trials under this time condition may not only reflect the increased difficulty of the task but also the significant impact of distracting factors, which appear to impair WM functioning in horses. Exogenous auditory stimuli, causing a reorientation of attention, negatively impacted the likelihood of success in experimental trials. Meanwhile, no evidence of endogenous distraction affecting performance was observed, suggesting that horses can maintain the representation of reasoning outcomes despite internal attention shifts. Endogenous distraction was defined as a situation in which the horse appeared to lost interest in the experimental setup and, for instance, chose to explore the box instead, without being triggered by any specific external stimulus.

It is important to note that not all auditory stimuli visibly distracted the horses, indicating that the sensitivity of equine orienting attention may vary individually and warrants further investigation. Currently, little is known about the functioning of the equine attentional system and its influence on cognitive task performance. These results suggest that exogenous distracting stimuli can significantly affect cognitive research outcomes in horses. The observed discrepancies in other studies might not only stem from variations in experimental protocols but also from the failure to account for potential exogenous stimuli, which, for flight animals like domestic horses, may act as stress-inducing factors.

References

- Auersperg, A. M. I., Szabo, B., von Bayern, A. M. P., and Bugnyar, T. (2014). Object permanence in the goffin cockatoo (*Cacatua goffini*). *Journal of Comparative Psychology*, 128, 88–98. doi: 10.1037/a0033272
- Baragli, P., Vitale, V., Paoletti, E., Mengoli, M., & Sighieri, C. (2011). Encoding the object position for assessment of short term spatial memory in horses (*Equus caballus*). *International Journal of Comparative Psychology*, 24(3), 284–291. doi:10.46867/ijcp.2011.24.03.02
- Barth, J., and Call, J. (2006). Tracking the displacement of objects: a series of tasks with great apes (*Pan troglodytes*, *Pan paniscus*, *Gorilla gorilla*, and *Pongo pygmaeus*) and young children (*Homo sapiens*). *Journal of Experimental Psychology*, 32, 239–252. doi: 10.1037/0097-7403.32.3.239
- Basile, B. M. & Hampton, R. R. (2013). Dissociation of active working memory and passive recognition in rhesus monkeys. *Cognition*, 126(3), 391-396, doi:10.1016/j.cognition.2012.10.012
- Beatty, W., & Shavalia, D. (1980). Spatial memory in rats: time course of working memory and effect of anesthetics.

- Behavioral and neural biology*, 28 4, 454-62. doi:10.1016/S0163-1047(80)91806-3
- Bizon, J., Foster, T., Alexander, G., & Glisky, E. (2012). Characterizing cognitive aging of working memory and executive function in animal models. *Frontiers in Aging Neuroscience*, 4. doi:10.3389/fnagi.2012.00019
- Cellai, S., Gazzano, A., Casini, L., Gazzano, V., Cecchi, F., Macchioni, F., Cozzi, A., Pageat, L., Arroub, S., Fratini, S., Felici, M., Curadi, M., & Baragli, P. (2024). The Memory Abilities of the Elderly Horse. *Animals*, 14(21):3073. doi:10.3390/ani14213073
- Chuderski, A., Taraday, M., Nęcka, E., & Smoleń, T. (2012). Storage capacity explains fluid intelligence but executive control does not. *Intelligence*, 40(3), 278–295. doi:10.1016/j.intell.2012.02.010
- Constantinidis, C., & Klingberg, T. (2016). The neuroscience of working memory capacity and training. *Nature Reviews Neuroscience*, 17, 438-449. doi:10.1038/nrn.2016.43
- Daneman, M., & Merikle, P. (1996). Working memory and language comprehension: A meta-analysis. *Psychonomic Bulletin & Review*, 3, 422-433. doi:10.3758/BF03214546
- Diekamp, B., Kalt, T., & Güntürkün, O. (2002). Working Memory Neurons in Pigeons. *The Journal of Neuroscience*, 22, RC210. doi:10.1523/JNEUROSCI.22-04-j0002.2002
- Dore, F. Y. & Dumas, C. (1987). Psychology of Animal Cognition: Piagetian Studies. *Psychological Bulletin*, 102, 219-233. Doi:10.1037/0033-2909.102.2.219
- Doré, F. Y., Fiset, S., Goulet, S., Dumas, M. C., and Gagnon, S. (1996). Search behavior in cats and dogs: interspecific differences in working memory and spatial cognition. *Animal Learning Behaviour*, 24, 142–149. doi: 10.3758/BF03198962
- Engle, R. (2002). Working Memory Capacity as Executive Attention. *Current Directions in Psychological Science*, 11, 19-23. doi:10.1111/1467-8721.00160
- Earl, B. (2023). Humans, fish, spiders and bees inherited working memory and attention from their last common ancestor. *Frontiers in Psychology*, 13:937712. doi:10.3389/fpsyg.2022.937712
- Evans, L., Cameron-Whytock, H., & Ijichi, C. (2024). Whoa, No-Go: Evidence consistent with model-based strategy use in horses during an inhibitory task. *Applied Animal Behaviour Science*, 277:106339, doi:10.1016/j.applanim.2024.106339
- Fiset, S., Beaulieu, C., & Landry, F. (2003). Duration of dogs' (*Canis familiaris*) working memory in search for disappearing objects. *Animal Cognition*, 6, 1-10. doi:10.1007/s10071-002-0157-4
- Fiset, S., & Doré, F. (2006). Duration of cats' (*Felis catus*) working memory for disappearing objects. *Animal Cognition*, 9, 62-70. doi:10.1007/s10071-005-0005-4
- Gabor, V., & Gerken, M. (2010). Horses use procedural learning rather than conceptual learning to solve matching to sample. *Applied Animal Behaviour Science*, 126, 119-124. doi:10.1016/J.APPLANIM.2010.06.006
- Gruszka, A., & Nęcka, E. (2017). Limitations of working memory capacity: The cognitive and social consequences. *European Management Journal*, 35, 776-784. doi:10.1016/J.EMJ.2017.07.001
- Hanggi, E. B. (2003). Discrimination learning based on relative size concepts in horses (*Equus caballus*). *Applied Animal Behaviour Science*, 83(3), 201-213. doi:10.1016/S0168-1591(03)00136-9
- Hanggi, E. B. (2010). Short-term Memory Testing in Domestic Horses: Experimental Design Plays a Role. *Journal of Equine Veterinary Science*, 30(11), 617–623. doi:10.1016/j.jvevs.2010.10.004
- Hausberger, M., Stomp, M., Sankey, C., Brajon, S., Lunel, C., & Henry, S. (2019). Mutual interactions between cognition and welfare: The horse as an animal model. *Neuroscience & Biobehavioral Reviews*, 107, 540-559. doi:10.1016/j.neubiorev.2019.08.022
- Hoffmann, A., Rüttler, V., and Nieder, A. (2011). Ontogeny of object permanence and object tracking in the carrion crow, *Corvus corone*. *Animal Behaviour*, 82, 359–367. doi: 10.1016/j.anbehav.2011.05.012
- Jaakkola, K. (2014). Do animals understand invisible displacement? A critical review. *Journal of comparative psychology*, 128 3, 225-39. doi:10.1037/a0035675
- Lampe, J., & Andre, J. (2012). Cross-modal recognition of human individuals in domestic horses (*Equus caballus*). *Animal Cognition*, 15, 623 – 630. doi:10.1007/s10071-012-0490-1
- Light, K., Kolata, S., Wass, C., Denman-Brice, A., Zagalsky, R., & Matzel, L. (2010). Working Memory Training Promotes General Cognitive Abilities in Genetically Heterogeneous Mice. *Current Biology*, 20, 777-782. doi:10.1016/j.cub.2010.02.034
- Lind, J., Enquist, M., & Ghirlanda, S. (2015). Animal memory: A review of delayed matching-to-sample data. *Behavioural Processes*, 117, 52-58. doi:10.1016/j.beproc.2014.11.019
- Lovrovich, P., Sighieri, C., & Baragli, P. (2015). Following human-given cues or not? Horses (*Equus caballus*) get smarter and change strategy in a delayed three choice task. *Applied Animal Behaviour Science*, 166, 80–88. doi:10.1016/j.applanim.2015.02
- Matzel, L., & Kolata, S. (2010). Selective attention, working memory, and animal intelligence. *Neuroscience & Biobehavioral Reviews*, 34, 23-30. doi:10.1016/j.neubiorev.2009.07.002
- McLean, A. (2004). Short-term spatial memory in the domestic horse. *Applied Animal Behaviour Science*, 85(1-2), 93-105. doi:10.1016/j.applanim.2003.09.009
- Mejdell, C. M., Buvik, T., Jørgensen, G. H., & Bøe, K. E. (2016). Horses can learn to use symbols to communicate their preferences. *Applied Animal Behaviour Science*, 184, 66-73. doi:10.1016/J.APPLANIM.2016.07.014

- Means, L., & Kennard, K. (1991). Working memory and the aged rat: Deficient two-choice win-stay water-escape acquisition and retention. *Physiology & Behavior*, 49, 301-307. doi:10.1016/0031-9384(91)90047-R
- Nawroth, C., von Borell, E., and Langbein, J. (2015). Object permanence in the dwarf goat (*Capra aegagrus hircus*): perseveration errors and the tracking of complex movements of hidden objects. *Applied Animal Behaviour Science*, 167, 20–26. doi: 10.1016/j.applanim.2015.03.010
- Nee, D., Brown, J., Askren, M., Berman, M., Demiralp, E., Krawitz, A., & Jonides, J. (2013). A meta-analysis of executive components of working memory. *Cerebral cortex*, 23(2), 264-82 . doi:10.1093/cercor/bhs007
- Piaget, J. (1954). *The Construction of Reality in the Child*. New York: International University Press.
- Proops, L., & McComb, K. (2012). Cross-modal individual recognition in domestic horses (*Equus caballus*) extends to familiar humans. *Proceedings of the Royal Society B: Biological Sciences*, 279, 3131 – 3138. doi:10.1098/rspb.2012.0626
- Proops, L., McComb, K., & Reby, D. (2009). Cross-modal individual recognition in domestic horses (*Equus caballus*). *Proceedings of the National Academy of Sciences*, 106, 947 – 951. doi:10.1073/pnas.0809127105
- Rhodes, S., Jaroslawska, A., Doherty, J., Belletier, C., Naveh-Benjamin, M., Cowan, N., Camos, V., Barrouillet, P., & Logie, R. (2018). Storage and processing in working memory: Assessing dual-task performance and task prioritization across the adult lifespan.. *Journal of experimental psychology. General*, 148(7), 1204-1227. doi:10.1037/xge0000539
- Rochais, C., Stomp, M., Sébilleau, M., Houdebine, M., Henry, S., & Hausberger, M. (2022). Horses' attentional characteristics differ according to the type of work. *PLoS ONE*, 17. doi:10.1371/journal.pone.0269974
- Rørvang, M., Christensen, J., Ladewig, J., & McLean, A. (2018). Social Learning in Horses—Fact or Fiction *Frontiers in Veterinary Science*, 5. doi:10.3389/fvets.2018.00212
- Rørvang, M. V., Ničová, K., Sassner, H., & Nawroth, C. (2021). Horses' (*Equus caballus*) Ability to Solve Visible But Not Invisible Displacement Tasks Is Associated with Frustration Behavior and Heart Rate. *Frontiers in Behavioral Neuroscience*, 15, 792035. Doi:10.3389/fnbeh.2021.79203
- Sophian, C. (1985). Understanding the movements of objects: Early developments in spatial cognition. *British Journal of Developmental Psychology*, 3(4), 321-333. doi: 10.1111/j.2044-835X.1985.tb00984.x
- Tavares, M., & Tomaz, C. (2002). Working memory in capuchin monkeys (*Cebus apella*). *Behavioural Brain Research*, 131, 131-137. doi:10.1016/S0166-4328(01)00368-0
- Trösch, M., Bertin, E., Calandreau, L., Nowak, R., Lansade, L. (2020). Unwilling or willing but unable: can horses interpret human actions as goal directed?. *Animal Cognition*, 23, 1035–1040. doi:10.1007/s10071-020-01396-x.
- Uller, C., & Lewis, J. (2009). Horses (*Equus caballus*) select the greater of two quantities in small numerical contrasts. *Animal Cognition*, 12, 733-738. doi:10.1007/s10071-009-0225-0
- Unsworth, N., Fukuda, K., Awh, E., & Vogel, E. (2015). Working Memory Delay Activity Predicts Individual Differences in Cognitive Abilities. *Journal of Cognitive Neuroscience*, 27, 853-865. doi:10.1162/jocn_a_00765
- Valenchon, M., Lévy, F., Fortin, M., Leterrier, C., & lansade, L. (2013). Stress and temperament affect working memory performance for disappearing food in horses, *Equus caballus*. *Animal Behaviour*, 86, 1233-1240. doi:10.1016/j.anbehav.2013.09.026
- Wathan, J., & McComb, K. (2014). The eyes and ears are visual indicators of attention in domestic horses. *Current Biology*, 24(15). doi:10.1016/j.cub.2014.06.023
- Zentall, T. R., and Raley, O. L. (2019). Object permanence in the pigeon (*Columba livia*): insertion of a delay prior to choice facilitates visible-and invisibledisplacement accuracy. *Journal of Comparative Psychology*, 133, 132–139. doi:10.1037/com0000134