

LAZY TOURNAMENTS AND MULTIDEGREES OF A PROJECTIVE EMBEDDING OF $\overline{M}_{0,n}$

Maria Gillespie^{*1}, Sean T. Griffin^{†2}, and Jake Levinson^{‡3}

¹*Department of Mathematics, Colorado State University, Fort Collins, CO, U.S.A.*
maria.gillespie@colostate.edu

²*Department of Mathematics, University of California Davis, Davis, CA, U.S.A.*
stgriffin@ucdavis.edu

³*Department of Mathematics, Simon Fraser University, Burnaby, BC, Canada*
jake.levinson@sfu.ca

Submitted: Jul 31, 2021; Accepted: Oct 10, 2022; Published: Mar 15, 2023

© The authors. Released under the CC BY license (International 4.0).

Abstract. We consider the (iterated) Kapranov embedding $\Omega_n : \overline{M}_{0,n+3} \hookrightarrow \mathbb{P}^1 \times \cdots \times \mathbb{P}^n$, where $\overline{M}_{0,n+3}$ is the moduli space of stable genus 0 curves with $n + 3$ marked points. In 2020, Gillespie, Cavalieri, and Monin gave a recursion satisfied by the multidegrees of Ω_n and showed, using two combinatorial insertion algorithms on certain parking functions, that the *total degree* of Ω_n is $(2n - 1)!! = (2n - 1) \cdot (2n - 3) \cdots 5 \cdot 3 \cdot 1$.

In this paper, we give a new proof of this fact by enumerating each multidegree by a set of boundary points of $\overline{M}_{0,n+3}$, via an algorithm on trivalent trees that we call a *lazy tournament*. The advantages of this new interpretation are twofold: first, these sets project to one another under the forgetting maps used to derive the multidegree recursion. Second, these sets naturally partition the complete set of boundary points on $\overline{M}_{0,n+2}$, of which there are $(2n - 1)!!$, giving an immediate proof of the total degree formula.

Keywords. Moduli spaces of curves, projective embeddings, multidegrees, trivalent trees

Mathematics Subject Classifications. 05E14, 14N10, 05C05, 14H10, 05A19, 05C85

1. Introduction

In this paper, we give a new interpretation of the multidegrees of the Deligne–Mumford moduli space $\overline{M}_{0,n+3}$ [DM69] of genus-0 stable curves with n marked points, under the projective embedding

$$\Omega_n : \overline{M}_{0,n+3} \hookrightarrow \mathbb{P}^1 \times \cdots \times \mathbb{P}^n$$

^{*}Partially supported by NSF DMS award number 2054391.

[†]Partially supported by NSF Grant DMS-1439786 while in residence at the Institute for Computational and Experimental Research in Mathematics in Providence, RI, during the Spring 2021 semester.

[‡]Partially supported by an AMS Simons Travel Grant and by NSERC Discovery Grant RGPIN-2021-04169.

called the *iterated Kapranov map*. This map, first studied by Keel and Tevelev [KT09], is one of the simplest ways to realize $\overline{M}_{0,n+3}$ as a projective variety. The divisor classes associated to Ω_n are the *omega classes*, modifications of the better-known *psi classes*. The composition of Ω_n with the Segre map yields the *log canonical embedding* $\overline{M}_{0,n+3} \hookrightarrow \mathbb{P}^{(n+1)!-1}$, essentially the most natural projective embedding of $\overline{M}_{0,n+3}$.

For a composition $\mathbf{k} = (k_1, \dots, k_n) \in \mathbb{Z}_{\geq 0}^n$, we write $\deg_{\mathbf{k}}(\Omega_n)$ for the \mathbf{k} -th *multidegree*, which counts the intersection points of $\overline{M}_{0,n+3}$ with k_i general hyperplanes pulled back from each \mathbb{P}^i factor, for $i = 1, \dots, n$. That is, $\deg_{\mathbf{k}}(\Omega_n)$ corresponds to (the degree of) an intersection product of omega classes in the cohomology ring of $\overline{M}_{0,n+3}$. The *total degree* $\deg(\Omega_n)$ is the sum of all the multidegrees; equivalently, it is the ordinary degree of the projectivization of the affine cone over $\Omega_n(\overline{M}_{0,n+3}) \subseteq \mathbb{P}^1 \times \dots \times \mathbb{P}^n$ in the affine space $\mathbb{A}^2 \times \mathbb{A}^3 \times \dots \times \mathbb{A}^{n+1} = \mathbb{A}^{n(n+3)/2}$ (see Van der Waerden [Wae78]).

Prior work [CGM21] showed that the multidegrees can be enumerated by certain parking functions, called *column-restricted parking functions* or *CPFs*. It was shown that CPFs satisfy a recursion for the multidegrees called the *asymmetric string equation* [CGM21], which states that for each \mathbf{k} ,

$$\deg_{\mathbf{k}}(\Omega_n) = \sum_{j>i} \deg_{\tilde{\mathbf{k}}_j}(\Omega_n), \quad (1.1)$$

where i is the index of the rightmost 0 in \mathbf{k} , and the $\tilde{\mathbf{k}}_j$ are certain compositions of $n-1$ (see Section 2.4 for details). This recursion arises geometrically from the forgetting map $\pi_i : \overline{M}_{0,n+3} \rightarrow \overline{M}_{0,n+2}$ along with certain relabeling maps $\text{relabel}_{\mathbf{k},j} : \overline{M}_{0,n+2} \xrightarrow{\sim} \overline{M}_{0,n+2}$. Using CPFs, the authors then find the following remarkable fact:

Theorem 1.1 ([CGM21, Theorem 1]). *The total degree of Ω_n is the odd double factorial $(2n-1)!!$.*

Theorem 1.1 is shown in [CGM21] via a second and more complicated combinatorial insertion algorithm on CPFs, different from the asymmetric string recurrence. The quantity $(2n-1)!!$, however, suggests a geometric reason for this result: $(2n-1)!!$ is also the total number of trivalent trees on $n+2$ (not $n+3$) leaves, i.e., the total number of boundary points on $\overline{M}_{0,n+2}$. In particular, it is natural to ask if there exist sets $T(\mathbf{k}) \subseteq \overline{M}_{0,n+3}$ for each $\mathbf{k} = (k_1, \dots, k_n)$ with $\sum k_i = n$, such that:

1. $|T(\emptyset)| = 1$,
2. For each \mathbf{k} , letting $i = i(\mathbf{k})$ and with relabeling maps defined as in the asymmetric string equation (see Section 2.4), we have $\pi_i(T(\mathbf{k})) = \bigcup_{j>i} \text{relabel}_{\mathbf{k},j}^{-1}(T(\tilde{\mathbf{k}}_j))$, counted with multiplicity,
3. The sets $T(\mathbf{k})$ are disjoint for distinct \mathbf{k} , and $\bigsqcup_{\mathbf{k} \models n} T(\mathbf{k})$ is the complete set of boundary points on a boundary divisor $D \subseteq \overline{M}_{0,n+3}$ that is isomorphic to $\overline{M}_{0,n+2}$.

Indeed, a collection of sets satisfying (1)–(2) has cardinalities $|T(\mathbf{k})| = \deg_{\mathbf{k}}(\Omega_n)$ for all \mathbf{k} by Equation (1.1), while visibly totaling $(2n - 1)!!$ by condition (3).

In this paper, we give an algorithm on trivalent trees we call a *lazy tournament* that associates to each \mathbf{k} a set $\text{Tour}(\mathbf{k}) \subseteq \overline{M}_{0,n+3}$; see Definition 1.2. We show that these points satisfy properties (1)–(3) above; see Proposition 3.13. Lazy tournament points then give an immediate proof of Theorem 1.1 on the total degree of Ω_n ; see Theorem 1.6 and Corollary 1.7. For completeness, we also give a bijection between the column-restricted parking functions of [CGM21] and our lazy tournament points (our proofs of Theorems 1.1 and 1.6 do not rely on this bijection).

These results add to a growing body of literature relating algebraic combinatorics and the geometry of moduli spaces of curves. The basic connection to trees via the boundary stratification (see Section 2) is long established. Enumerative questions have been of particular interest recently, including examining (as in this paper) many intersection products and structure constants on $\overline{M}_{g,n}$ [CL21, Sil22], tautological relations [CJ18, PP21, Pix13], and Schubert calculus involving limit linear series [CP21, EH86]. Other topics of interest include the S_n action on $H^*(\overline{M}_{0,n})$ over \mathbb{C} [BM13, Get95, RS22] and \mathbb{R} [Rai06], Chern classes of vector bundles on $\overline{M}_{0,n}$ associated to \mathfrak{sl}_r [DGT22, GKM02], explicit projective equations for $\overline{M}_{0,n}$ [MR17], and similar questions pertaining to a number of closely-related moduli spaces [CDH⁺22, CLQ22, Fry19, LLV20, Sha19].

Studying projective varieties by their projective embeddings is a common theme in combinatorial algebraic geometry. In particular, the Plücker embedding has been used to extract combinatorial and geometric data about the Grassmannian and more generally partial flag varieties [MS05, Ch. 14].

This is one of a collection of several papers [GGL22a, GGL22b] by the authors on the combinatorics of the embedding Ω_n and its associated geometric properties. Our work also adds to a growing list of work connecting multidegrees of projective varieties and combinatorics [CCRL⁺20, CGM21, KM05].

1.1. Lazy tournaments and main results

A boundary point of $\overline{M}_{0,n+3}$ may be represented as a leaf-labeled **trivalent tree**, that is, a tree with $n + 3$ labeled leaves for which every vertex has degree 1 or 3. We use the labels $a, b, c, 1, 2, 3, \dots, n$, as in Figure 1.1, and we order the labels $a < b < c < 1 < 2 < \dots < n$.

Definition 1.2. Let T be a leaf-labeled trivalent tree. The **lazy tournament** of T is a labeling of the edges of T computed as follows. Start by labeling each leaf edge (that is, an edge adjacent to a leaf vertex) by the value on the corresponding leaf, as in the second picture of Figure 1.1. Then iterate the following process:

1. **Identify which pair ‘face off’.** Among all pairs of labeled edges (i, j) (ordered so that $i < j$) that share a vertex and have a third unlabeled edge E attached to that vertex, choose the pair with the largest value of i .
2. **Determine the winner.** The larger number j is the *winner*, and the smaller number i is the *loser* of the match.

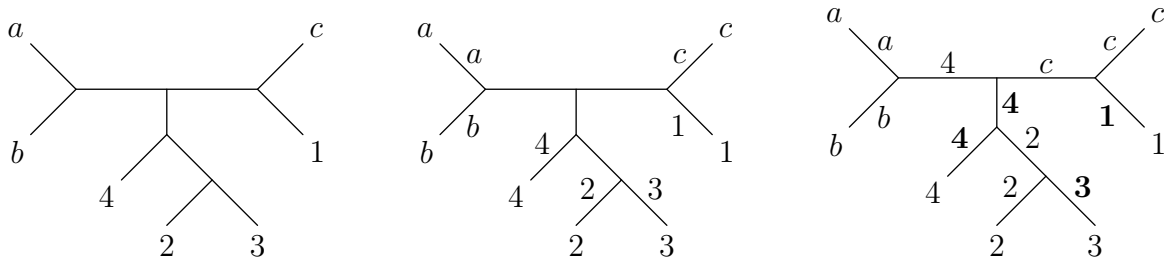

Figure 1.1: From left to right: A leaf-labeled trivalent tree T , its initial labeling of the leaf edges, and its full lazy tournament edge labeling. Winners of each round of the tournament are shown in boldface at right, indicating $T \in \text{Tour}(1, 0, 1, 2)$.

3. **Determine which of i or j advances to the next round.** Label E by either i or j as follows:

- (a) If E is adjacent to a labeled edge $u \neq j$ with $u > i$, then label E by i . (We say i advances.)
- (b) Otherwise, label E by j . (We say j advances.)

We then repeat steps 1-3 until all edges of the tree are labeled.

We refer to Step 3(a) above as the **laziness rule**, since j drops out of the tournament despite winning its match. This happens when j can see that its opponent i will be defeated, again, in its next round against u .

Definition 1.3. The **winners' composition** of a tree T is the composition $\mathbf{k} = (k_1, k_2, \dots, k_n)$ where k_i is the number of times the numbered label i wins in the lazy tournament of T .

We will primarily be concerned with tournaments on trees T in which leaf edges a and b share a vertex, in which c loses every round in which it competes and a and b never compete. Therefore the winners' composition will in general record the complete data of how many times each player wins.

An example of the result of the lazy tournament process is shown in Figure 1.1. For a more detailed example, see Example 3.1 below.

Remark 1.4. The lazy tournament algorithm is motivated by the morphisms π_i and $\text{relabel}_{\mathbf{k},j}$ in the asymmetric string equation (see Section 2.4). Specifically, we will show that Step (3) of Definition 1.2 agrees with applying $\text{relabel}_{\mathbf{k},j} \circ \pi_i$ to the corresponding stable curve (Lemma 3.12) and that this leads to an appropriate bijection (Lemma 3.13).

We can now state the main result, which says that the multidegrees may be enumerated by keeping track of the winners in all possible tournaments.

Definition 1.5. For any weak composition $\mathbf{k} = (k_1, \dots, k_n)$ of n , let $\text{Tour}(\mathbf{k})$ be the set of trivalent trees T whose leaves are labeled by $\{a, b, c, 1, \dots, n\}$, in which the leaf edges a and b share a vertex, and the winners' composition of T is \mathbf{k} .

For $n = 0$, we write $\mathbf{k} = \emptyset$ for the empty composition and we have $\text{Tour}(\emptyset) = \{T_0\}$, the unique such trivalent tree. In Figure 1.1, the tree T is in $\text{Tour}(1, 0, 1, 2)$.

Our first main result is the following:

Theorem 1.6. *We have $\deg_{\mathbf{k}}(\Omega_n) = |\text{Tour}(\mathbf{k})|$.*

As \mathbf{k} varies over all compositions, the sets $\text{Tour}(\mathbf{k})$ partition the complete set of boundary points on the divisor $\delta_{a,b} \cong \overline{M}_{0,\{b,c,1,\dots,n\}}$, consisting of curves in which a, b are alone on the same component. The boundary points on this divisor correspond to trivalent trees on $n + 2$ vertices, of which there are $(2n - 1)!!$. This completes the proof that the total degree of Ω_n is the odd double factorial.

Corollary 1.7. *The total degree of the embedding $\Omega_n : \overline{M}_{0,n+3} \rightarrow \mathbb{P}^1 \times \mathbb{P}^2 \times \dots \times \mathbb{P}^n$ is*

$$\deg(\Omega_n) = \sum_{k_1+\dots+k_n=n} \deg_{(k_1,\dots,k_n)}(\Omega_n) = \sum_{k_1+\dots+k_n=n} |\text{Tour}(k_1, \dots, k_n)| = (2n - 1)!!$$

for all n .

Given the equality $\deg_{\mathbf{k}}(\Omega_n) = |\text{Tour}(\mathbf{k})|$, it is also natural to ask if there is a set of hyperplanes (k_i taken from \mathbb{P}^i for each i) whose intersection with $\Omega_n(\overline{M}_{0,n+3})$ is $\text{Tour}(\mathbf{k})$. In general there are not, as the example below shows.

Example 1.8. The two trees in $\text{Tour}(1, 1)$, shown in Figure 1.2, represent boundary points whose coordinates (with the conventions of Section 2.2) under the map Ω_2 in $\mathbb{P}^1 \times \mathbb{P}^2$ are $[0 : 1] \times [0 : 1 : 0]$ and $[0 : 1] \times [0 : 1 : 1]$. In any choice of hyperplanes H_1 from \mathbb{P}^1 and H_2 from \mathbb{P}^2 intersecting the embedding in these two points, we must have that H_1 is the single point $[0 : 1]$ in \mathbb{P}^1 , and H_2 must be the line $[0 : 1 : t]$ in \mathbb{P}^2 . However, the intersection $[0 : 1] \times [0 : 1 : t]$ actually lies entirely on $\Omega_2(\overline{M}_{0,5})$, so the intersection is not transverse. See Example 2.4 in Section 2.3 for more details.

In investigating this question, we gave a different construction [GGL22a] to calculate products of both psi classes and omega classes, by taking certain explicitly-constructed *limits* of intersections of hyperplanes. A special case of that construction gives a (different) set of boundary points enumerating the multidegrees $\deg_{\mathbf{k}}(\Omega_n)$; however, the inductive structure is entirely different from that of the asymmetric string equation (the properties (1)–(3) stated above do not hold), and we do not know of a proof of the double factorial phenomenon using that approach.

In a handful of cases, the construction can be modified to produce the points $\text{Tour}(\mathbf{k})$ (see [GGL22a, Theorem 1.14]), but we do not know if this can be done in general. Towards this end, we include in this paper the weaker result that there is always a set of hyperplanes, k_i of them from \mathbb{P}^i for each i , whose intersection with $\Omega_n(\overline{M}_{0,n+3})$ contains $\text{Tour}(\mathbf{k})$.

Theorem 1.9. *Let $[z_b : z_c : z_1 : z_2 : \dots : z_{r-1}]$ be the projective coordinates of the \mathbb{P}^r factor in $\mathbb{P}^1 \times \dots \times \mathbb{P}^n$ (with the conventions of Section 2.2). Then the coordinates of the points of $\text{Tour}(k_1, \dots, k_n)$ in the \mathbb{P}^r component all lie on the k_r hyperplanes*

$$z_b = 0, z_c = 0, z_1 = 0, \dots, z_{k_r-2} = 0,$$

where if $k_r = 1$ then our collection only contains the hyperplane $z_b = 0$, and if $k_r = 2$ then we only have the two hyperplanes $z_b = 0$ and $z_c = 0$. (If $k_r = 0$ it is the empty collection.)



Figure 1.2: The two trees in $\text{Tour}(1, 1)$. In both, the c advances by the laziness rule on the first round, and is defeated once by each of 1 and 2.

The remainder of the paper is organized as follows. In Section 2, we provide some necessary background and definitions on the geometry of $\overline{M}_{0,n}$. In Section 3, we examine lazy tournaments and prove Theorem 1.6. In Section 4, we give a direct bijection between the lazy tournaments and the column restricted parking functions defined in [CGM21]. Finally, in Section 5, we prove Theorem 1.9.

2. Background

2.1. Structure of $\overline{M}_{0,X}$ and trivalent trees

Let $X = \{a, b, c, 1, \dots, n\}$. A point of $\overline{M}_{0,X}$ consists of an (isomorphism class of a) connected genus-0 curve C with at most nodal singularities and distinct, smooth marked points $p_i \in C$ labeled by the elements $i \in X$, such that each irreducible component has at least three **special points**, defined as marked points or nodes. The **dual tree** of a point of $\overline{M}_{0,X}$ is the graph consisting of an unlabeled vertex for each irreducible component $C' \subseteq C$, a vertex labeled i for each $i \in X$, and edges connecting i and the vertex corresponding to C' when $p_i \in C'$, and connecting C' and C'' when C' and C'' meet at a node. The resulting graph is always a tree since the curve has genus 0. (See Figure 2.1).

A tree is **trivalent** if every vertex has degree 1 or 3 and at least one vertex has degree 3. A tree is **at least trivalent** if it has no vertices of degree 2 and at least one vertex of degree ≥ 3 . Notice that the dual tree of any stable curve is at least trivalent.

Let Γ be an at-least-trivalent tree whose leaves are labeled by X . Then the **boundary stratum** D_Γ corresponding to Γ is the set of all stable curves whose dual tree is Γ . The boundary strata D_Γ form a quasi-affine stratification (as defined in [EH16]) of $\overline{M}_{0,X}$, and the zero-dimensional boundary strata, or **boundary points**, correspond bijectively to the trivalent trees on leaf set X . Indeed, since the points are isomorphism classes of stable curves and an automorphism of \mathbb{P}^1 is determined by where it sends three points, a stable curve whose dual tree is trivalent represents the only element of its isomorphism class.

When Γ has exactly two vertices of v, w of degree ≥ 3 , the closure \overline{D}_Γ is of codimension one, called a **boundary divisor**. For $i, j \in X$, we write $\delta_{i,j}$ for the boundary divisor with i, j on v and all other leaves adjacent to w .

2.2. The Kapranov morphism $\overline{M}_{0,n+3} \rightarrow \mathbb{P}^n$

For all facts stated throughout the next two subsections (2.2 and 2.3), we refer the reader to Kapranov's paper [Kap93], in which the Kapranov morphism below was originally defined.

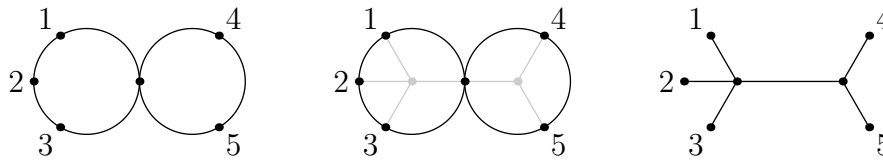

Figure 2.1: At left, a stable curve in $\overline{M}_{0,5}$, in which each circle represents a copy of \mathbb{P}^1 . At center, we form the dual tree Γ of the curve, by drawing a vertex in the center of each circle and then connecting it to each marked point and adjacent circle. At right, we show Γ . The set D_Γ is the dimension-1 boundary stratum consisting of all stable curves in which 1, 2, 3 are on one component and 4, 5 are on another.

The n th cotangent line bundle \mathbb{L}_n on $\overline{M}_{0,X}$ is the line bundle whose fiber over a curve $C \in \overline{M}_{0,X}$ is the cotangent space of C at the marked point n . The n -th ψ class is the first Chern class of this line bundle, written $\psi_n = c_1(\mathbb{L}_n)$. The corresponding map to projective space

$$|\psi_n| : \overline{M}_{0,X} \rightarrow \mathbb{P}^n,$$

is called the Kapranov morphism.

We coordinatize this map as follows. The map $|\psi_n|$ contracts each of the $n + 2$ divisors $\delta_{n,i}$, for $i \neq n$, to a point $\beta_i := |\psi_n|(\delta_{n,i}) \in \mathbb{P}^n$. These points are, moreover, in general linear position. We choose coordinates so that $\beta_b, \beta_c, \beta_1, \dots, \beta_{n-1} \in \mathbb{P}^n$ are the standard coordinate points $[1 : \dots : 0], \dots, [0 : \dots : 1]$ and β_a is the barycenter $[1 : 1 : \dots : 1]$. We name the projective coordinates $[z_b : z_c : z_1 : \dots : z_{n-1}]$.

Given a curve C in the interior $M_{0,X}$, by abuse of notation we also write $p_a, p_b, p_c, p_1, \dots, p_n$ for the coordinates of the $n + 3$ marked points on the unique component of C , after choosing an isomorphism $C \cong \mathbb{P}^1$. With these coordinates, the restriction of $|\psi_n|$ to the interior $M_{0,X}$ is given by

$$|\psi_n|(C) = \left[\frac{p_a - p_b}{p_n - p_b} : \frac{p_a - p_c}{p_n - p_c} : \frac{p_a - p_1}{p_n - p_1} : \dots : \frac{p_a - p_{n-1}}{p_n - p_{n-1}} \right]. \tag{2.1}$$

It is often convenient to choose coordinates on C in which $p_a = 0$ and $p_n = \infty$, in which case the map simplifies to

$$|\psi_n|(C) = [p_b : p_c : p_1 : \dots : p_{n-1}].$$

With this coordinatization, we can take limits from the interior to obtain coordinates of $|\psi_n|(C)$ for C on the boundary of $\overline{M}_{0,X}$. In particular, consider the boundary stratum given by the dual graph:

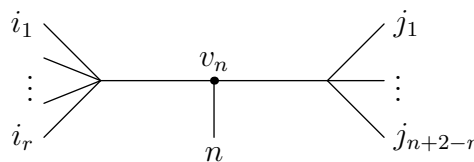

Here $\{a, b, c, 1, 2, \dots, n - 1\} = I \sqcup J$ where $I = \{i_1, \dots, i_r\}$ and $J = \{j_1, \dots, j_{n+2-r}\}$. Without loss of generality suppose $i_1 = a$. The points in this stratum may be obtained by

taking a limit having the property that the points p_i for $i \in I \setminus \{a\}$ approach $p_a = 0$ and the points p_j for $j \in J$ all approach 1 (and $p_n = \infty$). Thus, any point in this stratum has coordinates $[p_b : p_c : p_1 : \cdots : p_{n-1}]$ where $p_i = 0$ if $i \in I$ and $p_j = 1$ if $j \in J$. Now, since any trivalent tree is in the closure of a unique such stratum (by considering the two branches connected to the leaf edge n), we obtain the following.

Lemma 2.1. *Let C be a boundary point of $\overline{M}_{0,X}$ corresponding to the trivalent tree T . Let v_n be the internal vertex of T adjacent to the leaf edge whose leaf is labeled n , and consider the two remaining branches of T connected to v_n . Then $|\psi_n|(C) = [z_b : z_c : z_1 : z_2 : \cdots : z_n]$ where $z_i = 0$ if the leaf i is on the same branch as the leaf a , and $z_i = 1$ otherwise.*

Example 2.2. Consider the tree below.

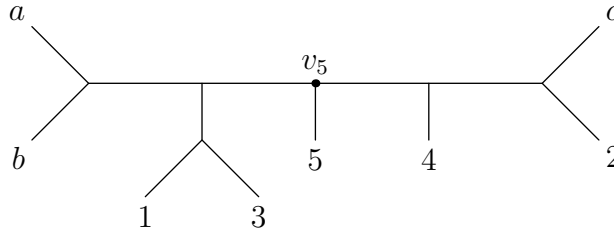

The 5 is the largest leaf, and it is connected to a vertex v_5 that is in turn connected to two other branches, one to the left of v_5 , and one to the right of v_5 . The branch on the left contains a , so we have $z_b = z_1 = z_3 = 0$ and, from the other branch, $z_c = z_2 = z_4 = 1$. Hence the tree maps under the Kapranov map to the point

$$[z_b : z_c : z_1 : z_2 : z_3 : z_4] = [0 : 1 : 0 : 1 : 0 : 1] \in \mathbb{P}^5.$$

2.3. The iterated Kapranov embedding Ω_n

Let $\pi_n : \overline{M}_{0,X} \rightarrow \overline{M}_{0,X \setminus n}$ be the n th forgetting map, which sends a stable curve C to the stable curve $\pi_n(C)$ obtained by forgetting the point marked by n , and then collapsing any components with only two special points. If the dual tree of C is T , then the dual tree of $\pi_n(C)$ is obtained from T by deleting the label n and its leaf, and then contracting any edges with degree 2.

The Kapranov morphism, combined with π_n , gives a closed embedding

$$\begin{aligned} \overline{M}_{0,X} &\hookrightarrow \mathbb{P}^n \times \overline{M}_{0,X \setminus n}. \\ C &\mapsto (|\psi_n|(C), \pi_n(C)). \end{aligned}$$

We may repeat this construction using the map $|\psi_{n-1}|$ on $\overline{M}_{0,X \setminus n}$, and so on, obtaining a sequence of embeddings. This gives the **iterated Kapranov morphism**

$$\Omega_n : \overline{M}_{0,X} \hookrightarrow \mathbb{P}^1 \times \mathbb{P}^2 \times \cdots \times \mathbb{P}^n.$$

The i -th factor of this embedding is given by forgetting the points p_{i+1}, \dots, p_n , then applying the Kapranov morphism $|\psi_i|$ on the smaller moduli space. We can also combine the forgetting maps with Lemma 2.1 to obtain the coordinates of any boundary point of $\overline{M}_{0,X}$ under the embedding.

Corollary 2.3. *Let C be a boundary point of $\overline{M}_{0,X}$ corresponding to the trivalent tree T . Given an integer $1 \leq r \leq n$, let T' be the tree corresponding to $\pi_{r+1} \circ \pi_{r+2} \circ \dots \circ \pi_n(C)$, let v_r be the internal vertex of T' adjacent to leaf edge r , and consider the three branches at v_r . Then the coordinates of $\Omega_n(C)$ in the \mathbb{P}^r factor are $[z_b : z_c : z_1 : \dots : z_r]$ where $z_i = 0$ if leaf i is on the same branch as a in T' , and $z_i = 1$ otherwise.*

Example 2.4. Consider the two points in $\text{Tour}(1, 1)$, shown below.



In the first, the 2 separates $a, b, 1$ from c , so it maps to $[0 : 1 : 0]$ in the \mathbb{P}^2 factor. In the second, the 2 separates a, b from $1, c$, so it maps to $[0 : 1 : 1]$ in the \mathbb{P}^2 factor.

In both, forgetting the point 2 yields the tree:

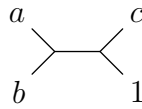

Here, the 1 separates a, b from c , so both points map to $[0 : 1]$ in the \mathbb{P}^1 factor. We therefore obtain, as claimed in Example 1.8, that the two points in $\text{Tour}(1, 1)$ map to $[0 : 1] \times [0 : 1 : 0]$ and $[0 : 1] \times [0 : 1 : 1]$.

Moreover, the only pair of hyperplanes from \mathbb{P}^1 and \mathbb{P}^2 that contains both defines the closure of the locus $[0 : 1] \times [0 : 1 : t]$, which are the coordinates of the points on the stratum:

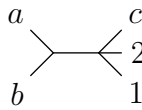

since we may think of the point 1 as varying on its component of the curve while c and 2 are fixed.

2.4. Omega classes and a recursion for the multidegrees

Definition 2.5. The i -th **omega class** is the pullback $\omega_i = \Omega_n^* H_i$, where H_i is the class of a hyperplane in the \mathbb{P}^i factor, lifted to $\mathbb{P}^1 \times \dots \times \mathbb{P}^n$. Equivalently, $\omega_i = f_i^* \psi_i$, where f_i is the composite forgetting map

$$f_i = \pi_{i+1} \circ \pi_{i+2} \circ \dots \circ \pi_n : \overline{M}_{0,n+3} \rightarrow \overline{M}_{0,i+3}.$$

Let $\mathbf{k} = (k_1, \dots, k_n)$ be a **weak composition** of n , that is, a sequence of nonnegative integers whose sum is n . We can express multidegrees as intersection products of omega classes: writing $\omega^{\mathbf{k}}$ for $\omega_1^{k_1} \dots \omega_n^{k_n}$,

$$\text{deg}_{(k_1, \dots, k_n)}(\Omega_n) = \int_{\overline{M}_{0,n+3}} \omega_1^{k_1} \omega_2^{k_2} \dots \omega_n^{k_n} = \int_{\overline{M}_{0,n+3}} \omega^{\mathbf{k}}.$$

The multidegrees of Ω_n satisfy a recursion, first shown in [CGM21], stated as Proposition 2.10 below.

Definition 2.6. For any weak composition $\mathbf{k} = (k_1, \dots, k_n)$ of n , define

$$i(\mathbf{k}) = \max\{\ell : k_\ell = 0\}$$

be the rightmost index i such that $k_i = 0$, or $i(\mathbf{k}) = c$ if $\mathbf{k} = (1, 1, 1, \dots, 1)$ is the unique composition of length n with no 0 entries. (Recall that we order the indices $a < b < c < 1 < 2 < \dots < n$.)

Definition 2.7 (Tilde Construction). Let $\mathbf{k} = (k_1, \dots, k_n)$ be a weak composition of n , and let j with $i(\mathbf{k}) < j \leq n$ be arbitrary. Then we define $\tilde{\mathbf{k}}_j$ to be the weak composition of size and length $n - 1$ formed by (a) decreasing k_j by 1 and then (b) removing the rightmost 0 in the resulting sequence (which is either the $i(\mathbf{k})$ -th or j -th entry).

Example 2.8. If $\mathbf{k} = (0, 1, 0, 0, 2, 1, 3)$, then $\tilde{\mathbf{k}}_5 = (0, 1, 0, 1, 1, 3)$ since it is formed by subtracting one from the fifth entry, 2, and removing the rightmost 0. On the other hand, $\tilde{\mathbf{k}}_6 = (0, 1, 0, 0, 2, 3)$ since it is formed by subtracting one from the sixth entry, 1, and then removing the new 0.

Definition 2.9 (Relabeling maps). Let \mathbf{k} be a composition, let $i = i(\mathbf{k})$ and let $i < j \leq n$. We define the isomorphism

$$\text{relabel}_{\mathbf{k},j} : \overline{M}_{0,abc1\dots\hat{i}\dots n} \rightarrow \overline{M}_{0,abc1\dots n-1}$$

by relabeling the marked points as follows. We have $k_j \neq 0$ by definition of $i(\mathbf{k})$. If $k_j > 1$, we decrement each of the labels $i + 1, \dots, n$ by 1. If $k_j = 1$, we instead send $j \mapsto i$ and decrement each of the labels $j + 1, \dots, n$ by 1.

Proposition 2.10 (Asymmetric string equation [CGM21, Prop 4.10]). *Let $i = i(\mathbf{k})$, and let $\pi_i : \overline{M}_{0,abc1\dots n} \rightarrow \overline{M}_{0,abc1\dots\hat{i}\dots n}$ be the forgetting map. Then we have*

$$\int_{\overline{M}_{0,abc1\dots n}} \omega^{\mathbf{k}} = \int_{\overline{M}_{0,abc1\dots\hat{i}\dots n}} (\pi_i)_*(\omega^{\mathbf{k}}) \tag{2.2}$$

$$= \int_{\overline{M}_{0,abc1\dots\hat{i}\dots n}} \sum_{j>i} (\text{relabel}_{\mathbf{k},j})^*(\omega^{\tilde{\mathbf{k}}_j}), \tag{2.3}$$

$$= \int_{\overline{M}_{0,abc1\dots n-1}} \sum_{j>i} \omega^{\tilde{\mathbf{k}}_j}. \tag{2.4}$$

In particular, the multidegrees satisfy the recursion

$$\text{deg}_{\mathbf{k}}(\Omega_n) = \sum_{j>i} \text{deg}_{\tilde{\mathbf{k}}_j}(\Omega_{n-1}). \tag{2.5}$$

Example 2.11 (See [CGM21, Ex. 4.6]). For $\mathbf{k} = (1, 0, 0, 0, 2, 1, 3)$, the asymmetric string equation gives

$$\int_{\overline{M}_{0,abc1234567}} \omega_1 \omega_5^2 \omega_6 \omega_7^3 \tag{2.6}$$

$$= \int_{\overline{M}_{0,abc123567}} (\pi_4)_*(\omega_1 \omega_5^2 \omega_6 \omega_7^3) \tag{2.7}$$

$$= \int_{\overline{M}_{0,abc123567}} (\text{relabel}_{\mathbf{k},5})^*(\omega_1 \omega_4 \omega_5 \omega_6^3) + (\text{relabel}_{\mathbf{k},6})^*(\omega_1 \omega_5^2 \omega_6^3) + (\text{relabel}_{\mathbf{k},7})^*(\omega_1 \omega_4^2 \omega_5 \omega_6^2) \tag{2.8}$$

$$= \int_{\overline{M}_{0,abc123456}} \omega_1 \omega_4 \omega_5 \omega_6^3 + \omega_1 \omega_5^2 \omega_6^3 + \omega_1 \omega_4^2 \omega_5 \omega_6^2. \tag{2.9}$$

Below, Proposition 3.13 shows that (in this example) the same operation π_4 and relabelings lead to a corresponding bijection

$$\text{Tour}(1, 0, 0, 0, 2, 1, 3) \xrightarrow{\sim} \text{Tour}(1, 0, 0, 1, 1, 3) \sqcup \text{Tour}(1, 0, 0, 0, 2, 3) \sqcup \text{Tour}(1, 0, 0, 2, 1, 2).$$

See also Example 3.11.

Note that the recursion (2.5) in Proposition 2.10 is similar to the recursion for the multinomial coefficients $\binom{n}{k_1, \dots, k_m} = \frac{n!}{k_1! k_2! \dots k_m!}$. Recall that for any composition (k_1, \dots, k_m) of n with all parts nonzero, we have

$$\binom{n}{k_1, \dots, k_m} = \sum_{j=1}^m \binom{n-1}{k_1, k_2, \dots, k_{j-1}, k_j-1, k_{j+1}, \dots, k_m}.$$

Defining the **asymmetric multinomial coefficient** to be the corresponding multidegree, that is,

$$\left\langle \binom{n}{k_1, \dots, k_n} \right\rangle = \text{deg}_{(k_1, \dots, k_n)}(\Omega_n),$$

we can restate Proposition 2.10 as

$$\left\langle \binom{n}{\mathbf{k}} \right\rangle = \sum_{j>i} \left\langle \binom{n-1}{\tilde{\mathbf{k}}_j} \right\rangle$$

for any weak composition \mathbf{k} of n into n parts.

3. Tournaments and the proof of Theorem 1.6

The main goal of this section is to prove Theorem 1.6, which we restate for convenience below. We say an edge of a tree is a **leaf edge** if it is adjacent to a leaf vertex. Also recall from Definition 1.5 that $\text{Tour}(k_1, \dots, k_n)$ is the set of trivalent trees T whose leaves are labeled by $\{a, b, c, 1, \dots, n\}$ in which the leaf edges a and b share a vertex, and the **winners' composition** (Definition 1.3) is (k_1, \dots, k_n) . That is, each label $i \geq 1$ wins exactly k_i times in the tournament of T .

Theorem 1.6. For any weak composition $\mathbf{k} = (k_1, \dots, k_n)$ of n , we have

$$\deg_{\mathbf{k}}(\Omega_n) = |\text{Tour}(\mathbf{k})|.$$

Recall the definition of a lazy tournament from Definition 1.2. We begin this section with an illustrative example of the tournament process.

Example 3.1. Start with the following tree, in which we have labeled each leaf edge by the label of the corresponding leaf:

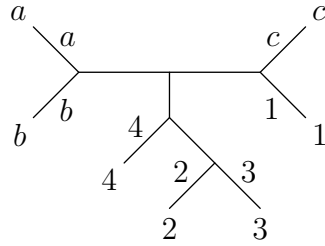

To start the tournament, we first compare all three pairs of leaves whose leaf edges share a vertex: (a, b) , $(2, 3)$, and $(c, 1)$. The one with the largest smaller entry is $(2, 3)$ (since the chosen ordering is $a < b < c < 1 < 2 < 3 < 4$) and so they face off first. The number 3 *wins*, and by the laziness rule with $u = 4$, the number 2 *advances*. We highlight the winner in boldface and draw the new label:

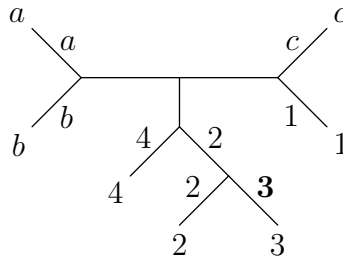

For the next round, our possible pairs are (a, b) , $(c, 1)$, and $(2, 4)$, so 2 and 4 face off next. The entry 4 wins (shown in boldface) and advances since the laziness rule does not apply:

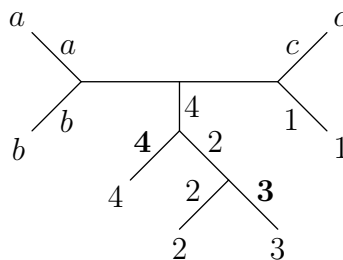

For the next round, our possible pairs are just (a, b) and $(c, 1)$, and the one with the larger smaller entry is $(c, 1)$. So 1 and c face off, with 1 winning and c advancing by the laziness rule with $u = 4$:

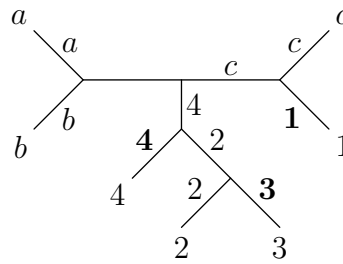

In the final round, c faces off against 4 , and 4 wins and advances:

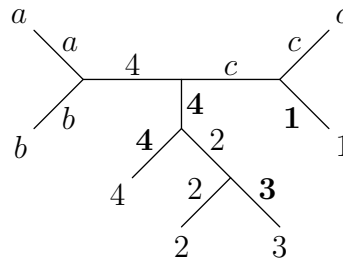

Since 1 won one round, 3 won one round, and 4 won two rounds, the winners' composition is $(1, 0, 1, 2)$. Therefore, this tree is an element of $\text{Tour}(1, 0, 1, 2)$.

Remark 3.2. A trivalent tree with $n+3$ labeled leaves has exactly n rounds in its lazy tournament. Notice also that player c can never win a round because it is the smallest player (besides a and b , who do not compete), and so the winners' composition contains the complete data of how many times each label wins. Therefore, the set of *all* trivalent trees with leaves labeled $a, b, c, 1, \dots, n$, such that the leaf edges of a and b share a vertex, is the disjoint union of $\text{Tour}(\mathbf{k})$ over all weak compositions $\mathbf{k} = (k_1, \dots, k_n)$ of n .

Before embarking on the proof of Theorem 1.6, we illustrate it in the case $n = 2$.

Example 3.3. The three leaf-labeled trivalent trees on $\{a, b, c, 1, 2\}$ in which the leaf edges of a and b share a vertex are shown below:

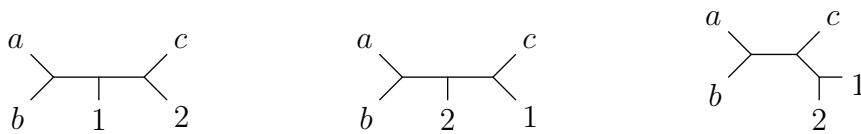

In the tournament of the first two, the labels 1 and 2 each win one round, and in the tournament of the third, the label 2 wins both rounds. Thus $|\text{Tour}(1, 1)| = 2$ and $|\text{Tour}(0, 2)| = 1$, and so by Theorem 1.6 we have $\deg_{(1,1)}(\Omega_2) = 2$, $\deg_{(0,2)}(\Omega_2) = 1$, and $\deg_{(2,0)}(\Omega_2) = 0$.

3.1. Combinatorial results about tournaments

We now prove a number of technical lemmas about tournaments that will be helpful in the proof of Theorem 1.6. The first is that the losing elements of each round weakly decrease as the tournament is run.

Lemma 3.4. *Let T be a trivalent tree on $n+3$ leaves, and let i_1, i_2, \dots, i_n be the smaller elements of the pairs that face off in its lazy tournament in each round, listed in order from start to finish. Then we have $i_1 \geq i_2 \geq \dots \geq i_n$.*

Proof. We show that $i_1 \geq i_2$; the remaining inequalities follow by induction on n .

The first pair of leaves to face off in the tournament is (i_1, j) for some $j > i_1$, and by the definition of the tournament, all other pairs of leaves (i', j') have $i' < i_1$. Let E be the third edge adjacent to leaf edges i_1 and j , as defined in Definition 1.2.

Case 1: Suppose E is not adjacent to any other labeled edge besides i_1 and j . Then after the first round, the new possible pairs to consider for determining who faces off next are all of the form (i', j') with $i' < i_1$. Since i_2 is among the values i' , we have $i_2 < i_1$.

Case 2: Suppose E is adjacent to two other labeled edges besides i_1 and j . Then we are at the last round of the tournament, and the statement of the lemma holds trivially.

Case 3: Suppose E is adjacent to exactly one other labeled edge u . If $u < i_1$, then j advances in the tournament and (u, j) becomes one of the new pairs to consider along with the other (i', j') pairs. So in the next round, i_2 is either u or one of the i' values, so since $u < i_1$ and each $i' < i_1$, we again have $i_2 < i_1$.

Otherwise, if $u > i_1$, then by the laziness rule i_1 advances, and it becomes a new pair (i_1, u) to consider for the next round; since i_1 is still largest among the smaller elements of each leaf pair (i', j') , we have $i_2 = i_1$ in this case.

Thus in all cases $i_1 \geq i_2$, and similarly $i_1 \geq i_2 \geq \dots \geq i_n$. \square

Definition 3.5. Given a label i of a leaf-labeled trivalent tree, we say i is a **winner** if it wins any round of the tournament, and it is a **loser** if it loses any round of the tournament.

The next two lemmas show that every label that participates in at least one match is either a winner or a loser but cannot be both. That is, “winners always win” and “losers always lose”.

Lemma 3.6 (Winners Lemma). *Suppose j is a label of a leaf-labeled trivalent tree. If j wins the first round in which it competes during the lazy tournament, then j wins all subsequent rounds in which it competes.*

Proof. Suppose j wins a round against $i < j$ and advances. Since the sequence of losers in the tournament decreases by Lemma 3.4, then j cannot appear after i in the list of losers. Therefore, j must win all of the subsequent rounds in which it competes. \square

Lemma 3.7 (Losers Lemma). *Suppose i is a label of a leaf-labeled trivalent tree. If i loses the first round in which it competes during the lazy tournament, then i loses all subsequent rounds in which it competes.*

Proof. If i loses but also advances to a future round, it must have done so via the laziness rule, and so it is already adjacent to another edge that is larger than it. Thus it also loses its next round, and so on. \square

We now restrict our attention to trivalent trees having a, b adjacent. Recall that $\text{Tour}(\mathbf{k})$ is the set of trivalent trees whose leaves are labeled by $\{a, b, c, 1, \dots, n\}$ with winners' composition \mathbf{k} in which the leaf edges a and b share a vertex. Note that i is a winner in such a tournament if and only if $k_i > 0$. We mention the following observation:

Lemma 3.8 (Participation Lemma). *Let $T \in \text{Tour}(\mathbf{k})$ for a weak composition \mathbf{k} of $n \geq 1$. In the tournament of T , neither a nor b compete in any round, and all of the other labels compete in some round. Moreover, when a label advances, it always advances forward along its path towards a .*

Finally, we consider the largest index i for which $k_i = 0$, which is used in the definition of $\tilde{\mathbf{k}}_j$ (Definition 2.7) and the asymmetric string equation. We show that it is the first and largest loser in the tournament. Moreover, we are in the lazy case (or not) depending on whether $k_j = 1$ or $k_j > 1$.

Lemma 3.9 (First Round Lemma). *Let $T \in \text{Tour}(\mathbf{k})$ and consider the pair (i_1, j) in the tournament of T that faces off first, written so that $i_1 < j$.*

1. *We have $i_1 = i(\mathbf{k})$, the index of the rightmost 0 in \mathbf{k} .*
2. *The laziness rule applies in this round if and only if $k_j = 1$ and $n \geq 2$.*

Proof. 1. Since i_1 loses every round it competes in (by Lemma 3.7), we have $k_{i_1} = 0$ by the definition of $\text{Tour}(\mathbf{k})$. Furthermore, by Lemma 3.6 and 3.8, the only indices i' with $k_{i'} = 0$ are those that lose a round at some point. By Lemma 3.4, these indices decrease as the tournament is run, so i_1 is the largest index for which $k_{i_1} = 0$, and so $i_1 = i(\mathbf{k})$.

2. If the laziness rule applies, then j does not advance, so evidently $k_j = 1$. Conversely, suppose $k_j = 1$ and (for contradiction) that j advances. By the Winners Lemma (3.6), j wins every round in which it competes, and by the Participation Lemma (3.8), j will compete in one more round unless $n = 1$. This gives a contradiction unless $n = 1$. \square

3.2. Proof of Theorem 1.6

In order to prove Theorem 1.6, we will show that the sets $\text{Tour}(\mathbf{k})$ satisfy the same recursion as the multidegrees (Proposition 2.10). For the remainder of this section, we fix $n \geq 1$ and a composition $\mathbf{k} = (k_1, \dots, k_n)$ of n , and we set $i := i(\mathbf{k})$.

Definition 3.10. We define a map

$$\pi_{\text{lazy}} : \text{Tour}(\mathbf{k}) \rightarrow \coprod_{j>i} \text{Tour}(\tilde{\mathbf{k}}_j)$$

as follows. Here, \coprod is coproduct (formal disjoint union) of sets, since the sets $\text{Tour}(\tilde{\mathbf{k}}_j)$ are not necessarily pairwise disjoint. Let $T \in \text{Tour}(\mathbf{k})$ and consider the pair (i, j) in the tournament of T that faces off first, with $j > i$. Then we define

$$\pi_{\text{lazy}}(T) := \text{relabel}_{\mathbf{k},j} \circ \pi_i(T).$$

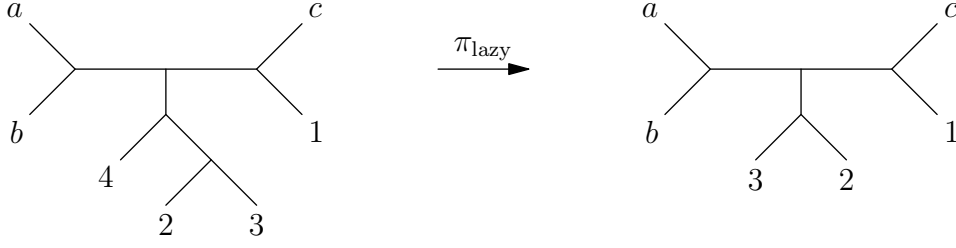

Figure 3.1: The map π_{lazy} applied to the tree from Example 3.1. Notice that applying π_{lazy} corresponds to running the first round of the tournament, deleting the two leaf edges that competed, and decrementing the higher label 4.

By Lemma 3.9(2), the two cases in the definition of $\text{relabel}_{\mathbf{k},j}$ correspond to whether or not the laziness rule applies to the first round of the tournament, so $\pi_{\text{lazy}}(T)$ also gives the tree that remains after letting either i or j advance (as appropriate), then decrementing the higher labels.

Below, in Lemma 3.12, we verify that this gives $\pi_{\text{lazy}}(T) \in \text{Tour}(\tilde{\mathbf{k}}_j)$, i.e. the winners' composition associated to $\pi_{\text{lazy}}(T)$ is $\tilde{\mathbf{k}}_j$. We will then show that π_{lazy} is a bijection. This formulation implies the property (2) stated in the introduction, that

$$\pi_i(\text{Tour}(\mathbf{k})) = \bigcup_{j>i} \text{relabel}_{\mathbf{k},j}^{-1}(\text{Tour}(\tilde{\mathbf{k}}_j))$$

as multisets.

An example of π_{lazy} is shown in Figure 3.1.

Example 3.11. Continuing Example 2.11, the following recursion holds:

$$\text{Tour}(1, 0, 0, 0, 2, 1, 3) \xrightarrow{\pi_{\text{lazy}}} \text{Tour}(1, 0, 0, 1, 1, 3) \amalg \text{Tour}(1, 0, 0, 0, 2, 3) \amalg \text{Tour}(1, 0, 0, 2, 1, 2). \quad (3.1)$$

Geometrically, π_{lazy} maps the corresponding points of $\overline{M}_{0,n+3}$ to $\overline{M}_{0,n+2}$ as in the diagram

$$\begin{array}{ccc} \overline{M}_{0,abc1234567} & \xrightarrow{\pi_4} & \overline{M}_{0,abc123567} \\ \cup & & \begin{array}{l} \nearrow \text{relabel}_{\mathbf{k},5} \rightarrow \overline{M}_{0,abc123456} \supset \text{Tour}(1, 0, 0, 1, 1, 3) \\ \rightarrow \text{relabel}_{\mathbf{k},6} \rightarrow \overline{M}_{0,abc123456} \supset \text{Tour}(1, 0, 0, 0, 2, 3) \\ \searrow \text{relabel}_{\mathbf{k},7} \rightarrow \overline{M}_{0,abc123456} \supset \text{Tour}(1, 0, 0, 2, 1, 2). \end{array} \\ \text{Tour}(1, 0, 0, 0, 2, 1, 3) & & \end{array}$$

Here, by Lemma 3.9 the laziness rule applies only when the first round of the tournament has $(i, j) = (4, 6)$, corresponding to $\text{relabel}_{\mathbf{k},6}$.

Lemma 3.12. *The map π_{lazy} is a well-defined map to $\coprod_{j>i} \text{Tour}(\tilde{\mathbf{k}}_j)$; in particular, if $T \in \text{Tour}(\mathbf{k})$ and j is the winner of the first round of the tournament of T , then $\pi_{\text{lazy}}(T) \in \text{Tour}(\tilde{\mathbf{k}}_j)$.*

Proof. Let $T \in \text{Tour}(\mathbf{k})$ and let j be the winner of the first round of T , facing off against $i < j$. Recording the winners for rounds $2, \dots, n$ on T gives the composition $\mathbf{k}' = (k_1, \dots, k_j - 1, \dots, k_n)$. By Lemma 3.9, $\pi_{\text{lazy}}(T)$ is the tree given by forgetting the label that does not advance (and decrementing the higher labels), so its tournament runs the same way as the remainder of the tournament for T . The winners' composition \mathbf{k}'' for $\pi_{\text{lazy}}(T)$ is therefore given by deleting the i th or j th entry of \mathbf{k}' , according to which of i or j did not advance. On the other hand, $\tilde{\mathbf{k}}_j$ is given by deleting the rightmost 0 of \mathbf{k}' . By the laziness rule and Lemma 3.9, these are the same entry. Thus $\mathbf{k}'' = \tilde{\mathbf{k}}_j$, so $\pi_{\text{lazy}}(T) \in \text{Tour}(\tilde{\mathbf{k}}_j)$. \square

Proposition 3.13. *The map π_{lazy} is a bijection.*

Proof. We construct the inverse of π_{lazy} . Given an element $T' \in \text{Tour}(\tilde{\mathbf{k}}_j)$ for some $j > i$, we construct the unique $T \in \text{Tour}(\mathbf{k})$ such that $\pi_{\text{lazy}}(T) = T'$ as follows.

Case 1. If $k_j > 1$, define T by increasing the labels $i, i + 1, i + 2, \dots, n$ by 1 each in T' , splitting the leaf edge of i into two edges with middle vertex v , and then attaching a leaf edge labeled i to v . By the definition of $\tilde{\mathbf{k}}_j$, the rightmost 0 in $\tilde{\mathbf{k}}_j$ occurs strictly before i , so all losers in T' are less than i . Thus the pair (i, j) is the first to face off in T . Moreover, if there is a labeled edge u adjacent to the empty edge connected to (i, j) in T , assume for contradiction that $u > i$. Then $(u - 1, j - 1)$ was a pair of leaves that faced off in T' , so $u - 1 < i$ and so $u \leq i$, a contradiction. Hence in T , j advances after defeating i , and therefore $T \rightarrow T'$ under our map.

Case 2. If $k_j = 1$, define T by first increasing the labels $j, j + 1, \dots, n$ by 1 each in T' , splitting the leaf edge of j into two edges with middle vertex v , and then attaching a leaf edge labeled j to v . Note that since $k_j = 1$ we have $(\tilde{\mathbf{k}}_j)_i = 0$ by the definition of $\tilde{\mathbf{k}}_j$, and moreover i is the index of the last 0 in $\tilde{\mathbf{k}}_j$. Thus i was the loser of the first match in T' , meaning it was paired with a larger entry $u > i$ in the first round of T' . Thus in T , the laziness rule applies in the match between i and j , and j sends i along to face off against u . It follows that our map above sends $T \rightarrow T'$ as desired. \square

Proof of Theorem 1.6 and Corollary 1.7. By Proposition 3.13 and induction,

$$|\text{deg}_{\mathbf{k}}(\Omega_n)| = |\text{Tour}(\mathbf{k})|.$$

For the Corollary, the sets $\text{Tour}(\mathbf{k})$ are disjoint as \mathbf{k} varies, and $\bigsqcup_{\mathbf{k}} \text{Tour}(\mathbf{k})$ is the set of all trivalent trees on the stratum $\delta_{a,b} \cong \overline{M}_{0,n+2}$. It is well-known that there are $(2n - 1)!!$ such trees. \square

Remark 3.14. The fact that there are $(2n - 1)!!$ trivalent trees on $n + 2$ labels is by a simple inductive count: for each tree T' on $n + 1$ labels, there are $2n - 1$ ways to insert the last leaf edge: it can be attached to the leaf edge labeled by one of the marked points $c, 1, 2, \dots, n - 1$, or to one of the $n - 1$ non-leaf edges in T' .

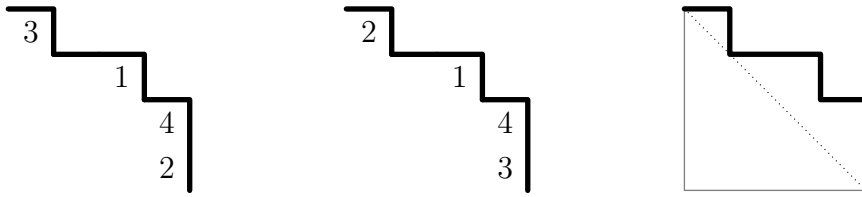

Figure 4.1: At left, a column-restricted parking function in the set $\text{CPF}(1, 0, 1, 2)$ since the number of labels in each column from left to right are 1, 0, 1, 2. At middle, a parking function which is not column-restricted, since $d_2 = 2$. At right, their Dyck path, shown staying above the diagonal from $(0, 4)$ to $(4, 0)$.

4. Parking functions

In [CGM21], the multidegrees $\text{deg}_{\mathbf{k}}(\Omega_n)$ were shown to enumerate a type of parking function called a *column restricted parking function* (CPF). In this section we give a bijection between CPFs and lazy tournaments.

We first recall the general definition of a parking function, as in [Hag93], though we draw our Dyck paths using down and right steps rather than up and right, as seen in, for instance, [BMPS19]. This will be useful for avoiding the extra step of reversing the sequence \mathbf{k} (as in [CGM21]).

Definition 4.1. A **Dyck path** of height n is a lattice path in the plane from $(0, n)$ to $(n, 0)$, using right $(1, 0)$ and down $(0, -1)$ unit steps, that stays weakly above the diagonal line connecting the two endpoints.

Definition 4.2. A **parking function** is a way of labeling the unit squares just to the left of the downward steps of a Dyck path with the numbers $1, 2, \dots, n$ such that the numbers in each column are increasing up the column. For $1 \leq i \leq n$, the *i th column* of a parking function is the i th column of squares from the left in the $n \times n$ box that contains it. We write $\text{PF}(n)$ for the set of parking functions of size n .

Two examples of parking functions of height 4 are shown in Figure 4.1.

4.1. Column-restricted parking functions

Definition 4.3. Let P be a parking function. For every number label x in P , we say x **dominates** a column to its right if the column contains no entry greater than x . Define the **dominance index** d_x to be the number of columns to the right of x dominated by x (including empty columns). Then we say P is **column-restricted** if $x > d_x$ for all $x = 1, 2, 3, \dots, n$. We write $\text{CPF}(k_1, \dots, k_n)$ for the set of column-restricted parking functions having exactly k_i labels in the i -th column for all i .

Theorem 4.4 (Theorem 1.1 in [CGM21]). *We have $\text{deg}_{(k_1, \dots, k_n)}(\Omega_n) = |\text{CPF}(k_1, \dots, k_n)|$.*

This theorem was proven by showing that the quantities $|\text{CPF}(k_1, \dots, k_n)|$ satisfy the recursion of Proposition 2.10, using the following map.

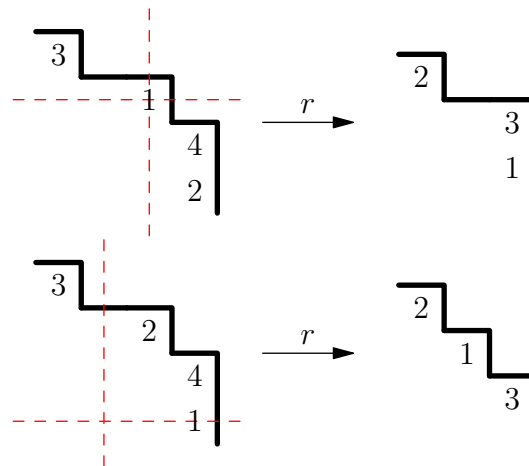

Figure 4.2: Applying the map r to column-restricted parking functions. At left is the case in which the 1 is in its own column ($k_j = 1$) and at right, the case in which 1 shares a column with other labels ($k_j > 1$). Notice that the result is column-restricted in each case.

Definition 4.5. We define $r : \text{PF}(n) \rightarrow \text{PF}(n - 1)$ as follows: given a parking function P , $r(P)$ is defined by removing the row containing the number 1, decrementing all remaining labels, and then deleting the rightmost empty column, as shown in Figure 4.2.

The following result shows that r restricts to a bijection on column restricted parking functions. (Note that in [CGM21], r was called φ .)

Proposition 4.6 (Proof of Theorem 5.3 in [CGM21]). *The map r induces a bijection*

$$\hat{r} : \text{CPF}(\mathbf{k}) \rightarrow \prod_{j>i} \text{CPF}(\tilde{\mathbf{k}}_j). \tag{4.1}$$

We will need the following additional lemma about CPFs.

Lemma 4.7. *Suppose $P \in \text{PF}(n)$ has first dominance index $d_1 = 0$ and $r(P)$ is column-restricted. Then P is column-restricted as well.*

Proof. Let i be the index of the rightmost empty column of P , and let j be the column containing the 1. First suppose x is a label in P to the right of column i . Then all columns to the right of x are nonempty, and so x dominates at most $x - 1$ columns to its right (if these columns have largest entries $1, 2, \dots, x - 1$). Thus $d_x < x$ as required.

Now suppose x is a label to the left of column i in P . Then $x - 1$ is the corresponding label in $r(P)$ and it dominates no more than $x - 2$ columns to its right. Then in P , x dominates at most one more column to its right, namely either the empty column i if 1 is not in its own column, or column j if 1 is in its own column in column j . Thus $d_x \leq x - 1$ as required. \square

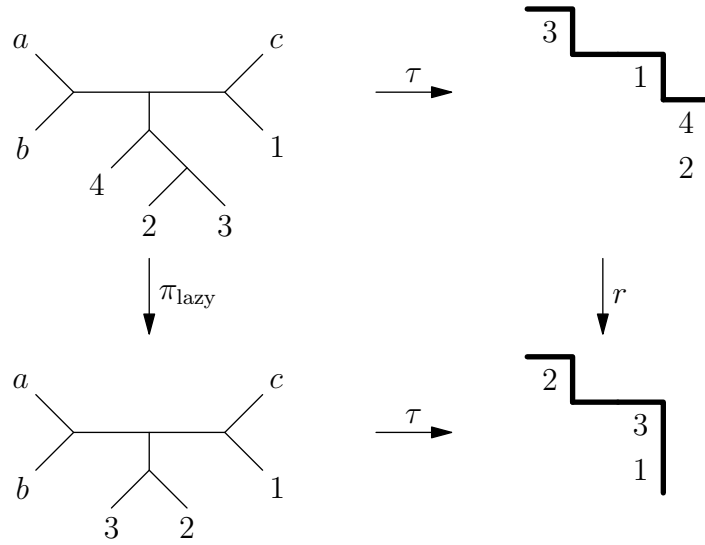

Figure 4.3: Tracing a tree $T \in \text{Tour}(1, 0, 1, 2)$ through the commutative diagram (4.3).

4.2. Bijection with tournaments

We now construct an explicit bijection $\tau : \text{Tour}(k_1, \dots, k_n) \rightarrow \text{CPF}(k_1, \dots, k_n)$ that makes the following diagram of bijections commute, where \hat{r} is the map (4.1) defined above.

$$\begin{array}{ccc}
 \text{Tour}(\mathbf{k}) & \xrightarrow{\tau} & \text{CPF}(\mathbf{k}) \\
 \downarrow \pi_{\text{lazy}} & & \downarrow \hat{r} \\
 \coprod_{j>i} \text{Tour}(\tilde{\mathbf{k}}_j) & \xrightarrow{\coprod \tau} & \coprod_{j>i} \text{CPF}(\tilde{\mathbf{k}}_j),
 \end{array} \tag{4.2}$$

Here $\coprod \tau$ is induced by the maps $\tau : \text{Tour}(\tilde{\mathbf{k}}_j) \rightarrow \text{CPF}(\tilde{\mathbf{k}}_j)$. Recall our convention that the columns of a parking function are numbered $1, 2, \dots, n$ from left to right.

Definition 4.8. Given a trivalent tree $T \in \text{Tour}(\mathbf{k})$, we define $\tau(T)$ to be the unique parking function of size n such that for each $1 \leq m \leq n$, the number m is in column j , where j is the winner of round m in the tournament of T .

Example 4.9. In the tournament T in Example 3.1, Round 1 was won by the number 3, so $\tau(T)$ has the label 1 in column 3. Round 2 was won by 4, so the label 2 appears in column 4 in $\tau(T)$. Round 3 was won by 1, so 3 appears in column 1, and Round 4 was won by 4, so 4 appears in column 4. Thus $\tau(T)$ is the unique parking function whose sets of column labels, from left to right, are $\{3\}, \{\}, \{1\}, \{2, 4\}$, as shown in the upper right of Figure 4.3.

As shown in [CGM21], one can use the recursion of Proposition 2.10 to show that the multidegree $\text{deg}_{(k_1, \dots, k_n)}(\Omega_n)$ is nonzero if and only if the sequence (k_1, \dots, k_n) is a reverse Catalan sequence, meaning that $k_n + k_{n-1} + k_{n-2} + \dots + k_{n-i+1} > i$ for all i . It is therefore an immediate consequence that applying τ to any tree $T \in \text{Tour}(\mathbf{k})$ does indeed result in a parking function, with column heights k_1, \dots, k_n .

Lemma 4.10. *For any $T \in \text{Tour}(\mathbf{k})$, we have $r(\tau(T)) = \tau(\pi_{\text{lazy}}(T))$. That is, the following diagram commutes:*

$$\begin{array}{ccc}
 \text{Tour}(\mathbf{k}) & \xrightarrow{\tau} & \text{PF}(n) \\
 \downarrow \pi_{\text{lazy}} & & \downarrow r \\
 \prod_{j>i} \text{Tour}(\tilde{\mathbf{k}}_j) & \xrightarrow{\tau} & \text{PF}(n-1).
 \end{array} \tag{4.3}$$

Proof. Let $T \in \text{Tour}(\mathbf{k})$, and let $i < j$ be the first pair that face off against each other in the tournament of T . Then j is the column of the number 1 in $\tau(T)$, and i is the largest index for which $k_i = 0$ by Lemma 3.9. In particular, the 1 is to the right of the rightmost empty column of $\tau(T)$. The parking function $r(\tau(T))$ is the result of deleting the row containing the 1 in $\tau(T)$, decrementing all remaining labels, and then deleting the rightmost empty column of the resulting diagram, which is column i if $k_j > 1$ and column j otherwise. This has the effect of decreasing the column indices of any label to the right of column i or j respectively by 1.

On the other hand, the tree $\pi_{\text{lazy}}(T)$ is formed by running the first round of the tournament, deleting the used leaf edges i, j , and decrementing all the labels above j or i respectively according to whether $k_j = 1$ or $k_j > 1$. Under τ , this corresponds to shifting all columns to the right of j or i respectively to the left one step, and also removing the 1 and decrementing the remaining labels since the second round of the original tournament is now the first round of $\pi_{\text{lazy}}(T)$. Thus $r(\tau(T)) = \tau(\pi_{\text{lazy}}(T))$ as desired. \square

We now need to show that the parking functions obtained from $\text{Tour}(\mathbf{k})$ by applying τ are precisely the column-restricted parking functions.

Proposition 4.11. *The map τ is a bijection from $\text{Tour}(\mathbf{k}) \rightarrow \text{CPF}(\mathbf{k})$ for any weak composition $\mathbf{k} = (k_1, \dots, k_n)$ of n , and the diagram (4.2) commutes.*

Proof. We first show that $\tau(T)$ is in $\text{CPF}(\mathbf{k})$ by induction on n . In the base case $n = 1$, this is easily checked, so assume the claim holds for compositions of $n - 1$. Letting $i < j$ be the pair that faces off first in T , then $r(\tau(T)) = \tau(\pi_{\text{lazy}}(T)) \in \text{CPF}(\tilde{\mathbf{k}}_j)$ by our inductive hypothesis. By the definition of τ , the label 1 is in column j of $\tau(T)$. By Lemma 3.9, i is the largest index such that $k_i = 0$, and since $i < j$, there are no empty columns to the right of the label 1. Therefore, we have $1 > d_1 = 0$ as in Definition 4.3 of column restrictedness. Since $r(\tau(T))$ is also column restricted, we have that $\tau(T)$ is column restricted by Lemma 4.7. Hence, $\tau(T) \in \text{CPF}(\mathbf{k})$ and the induction is complete.

Because (4.3) commutes by Lemma 4.10 and $\tau(T) \in \text{CPF}(\mathbf{k})$ for any $T \in \text{Tour}(\mathbf{k})$, it follows that (4.2) commutes as well. Finally, we show that $\tau : \text{Tour}(\mathbf{k}) \rightarrow \text{CPF}(\mathbf{k})$ is a bijection by induction on n . The claim is easily checked for $n = 1$, so assume the claim holds for all compositions of size $n - 1$. The map π_{lazy} is a bijection by Proposition 3.13, τ is a bijection from $\text{Tour}(\tilde{\mathbf{k}}_j)$ to $\text{CPF}(\tilde{\mathbf{k}}_j)$ for any $j > i$ by our inductive hypothesis, and r is a bijection by [CGM21]. Therefore, τ is also a bijection from $\text{Tour}(\mathbf{k})$ to $\text{CPF}(\mathbf{k})$ by commutativity of the diagram (4.2). \square

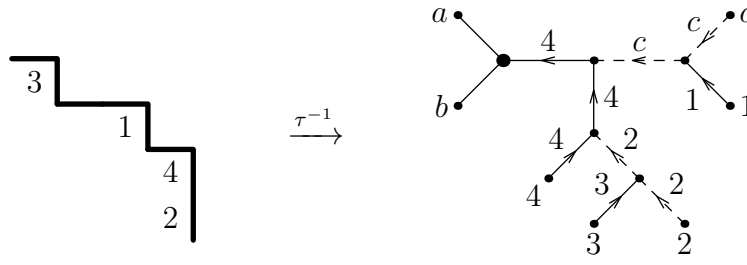

Figure 4.4: Reversing the bijection τ . We draw the losers as dashed edges and the winners as solid edges, and build the tree outwards starting from the vertex adjacent to a, b .

Remark 4.12. There is a natural way to combinatorially reverse the bijection τ , to directly compute the tree $\tau^{-1}(P)$ from a column restricted parking function P . As an example, let P be the parking function shown at left in Figure 4.4. We first identify the winners and losers; looking at which columns are nonempty, we find that 1, 3, 4 are winners and $c, 2$ are losers. We then read the cars of P from largest to smallest, and build a tree accordingly starting with the vertex connected to a, b and branching out to form each round.

The column of the car in question indicates the winner of the round, and it is paired with the *smallest* available loser such that the sequence of losers considered in this process is weakly increasing. In particular, if the car is at the top of its column, it pairs with the previous loser that was considered, and otherwise it pairs with the next smallest loser. In Figure 4.4, the largest car is in column 4, so 4 is the final winner against the smallest loser c , and we branch out accordingly. Then, the second-largest car is in column 1, who also can win against c . When we get to the next winner, 4 again, it can not be paired with c again, so we pair it with the next smallest loser, 2, and so on.

5. Hyperplanes containing the tournament points

A natural question in light of Theorem 1.6 is whether the set $\text{Tour}(\mathbf{k})$ can be obtained as a complete intersection of $\overline{M}_{0,X}$ with an appropriate set of hyperplanes in the iterated Kapranov embedding. As shown in Example 1.8, this is not possible in general, because the linear span of $\text{Tour}(\mathbf{k})$ (in a given factor of the embedding) may intersect the image of $\overline{M}_{0,X}$ in a subset of dimension $> \dim(\overline{M}_{0,X}) - k_i$.

It is sometimes possible, however, to express $\text{Tour}(\mathbf{k})$ as the *limit* of such an intersection, using a varying family of hyperplanes as in [GGL22a, Theorem 1.14]. We do not know if such a limit exists in general, but a necessary condition is that there is, for each i , a (fixed) codimension- k_i plane from \mathbb{P}^i containing $\text{Tour}(\mathbf{k})$. We end by showing that such hyperplanes do indeed exist. We restate Theorem 1.9 here for convenience.

Theorem 1.9. *Let $[z_b : z_c : z_1 : z_2 : \dots : z_{r-1}]$ be the projective coordinates of the \mathbb{P}^r coordinate in $\mathbb{P}^1 \times \dots \times \mathbb{P}^n$. Then the coordinates of the points of $\text{Tour}(k_1, \dots, k_n)$ in the \mathbb{P}^r factor all lie on the k_r hyperplanes*

$$z_b = 0, z_c = 0, z_1 = 0, \dots, z_{k_r-2} = 0,$$

where if $k_r = 1$ then our collection only contains the hyperplane $z_b = 0$, and if $k_r = 2$ then we only have the two hyperplanes $z_b = 0$ and $z_c = 0$. (If $k_r = 0$ it is the empty collection.)

To prove this, we first require two technical lemmas. A **branch** of a tree from a vertex v is a connected component of the graph formed by deleting vertex v (and all edges directly adjacent to it). We will say that two labels i, j are in different branches (resp., the same branch) **from the perspective of r** in a tree T if they are on different branches (resp., the same branch) from the internal vertex v_r adjacent to leaf edge r . If they are on different branches, we also say that r **separates** i from j in T .

Lemma 5.1. *Let $T \in \text{Tour}(\mathbf{k})$, let r be a winner in T , and suppose that the label r in $T' = \pi_{r+1} \circ \dots \circ \pi_n(T)$ separates some label ℓ from a . Then r separates ℓ from a in T , as well.*

Proof. Note that T is obtained from T' by successively inserting the numbers $r + 1, \dots, n$ as leaf edges attached to existing edges starting from T' . We claim that the property of r separating ℓ from a still holds in T . Indeed, let $T'_r, T'_a,$ and T'_ℓ be the three branches of the tree attached to r 's internal vertex in T' , which contain r, a, ℓ respectively. If the labels $r + 1, \dots, n$ are all inserted at edges in either T'_a or T'_ℓ , it is clear that r still separates ℓ from a .

If instead one of the labels $r + 1, \dots, n$ is inserted on the unique edge in T'_r (with possibly more inserted on the resulting edges), then r would be paired in its first round of the tournament with some label among $r + 1, \dots, n$, and therefore r loses its first round. This is a contradiction to the Losers Lemma (3.7) since r is a winner. Thus r separates ℓ from a in T as well. \square

Lemma 5.2. *Let v be a vertex of a tree $T \in \text{Tour}(\mathbf{k})$ and let B be a branch at v not containing a . Let m be the smallest leaf label of B and let P be the path from m to v .*

By the time m first participates in a round of the tournament of T , every edge of B is labeled except those along P .

Moreover, m faces off against every labeled edge of B attached to P and advances until at least the vertex just before v in P .

Proof. If B consists only of the leaf edge m , the result holds trivially. So assume B contains at least one leaf besides m .

Since m is minimal in B , it is paired in its first round with another element $p > m$ in B , so m is a loser of the tournament. Since the sequence of losers weakly decreases (Lemma 3.4) and m is minimal in B , all other pairs in B will face off before m 's first round.

Now, suppose for contradiction that some edge on path P from m to v becomes labeled before m 's first round. This is only possible if the two other edges adjacent to v (not in branch B) are labeled and then face off to label an edge in path P . However, by the Participation Lemma (3.8), labels that advance in the tournament do so along their path towards a , and since a is not in branch B , we have a contradiction. Hence P is unlabeled until m starts competing, at which point it advances by the laziness principle against all of its opponents in branch B except possibly the last. \square

Proof of Theorem 1.9. First note that since the leaf edges of a and b share a vertex in all tournament points, b is on a 's branch from the perspective of any other vertex of the tree, so $z_b = 0$ always holds. In particular, we only have to consider the case $k_r \geq 2$.

Since $k_r \geq 2$, for any $T \in \text{Tour}(k_1, \dots, k_n)$, the number r wins at least two rounds of the tournament of T by the definition of $\text{Tour}(\mathbf{k})$. Let P be the path from c to a , let v_a be the internal vertex at leaf edges a, b , and let B be the branch from v_a not containing a, b . Then c is the minimal label in B , so by Lemma 5.2, a leaf edge attached to P only faces off against c (and then c advances by the laziness rule). Thus r itself is not directly attached to a vertex on path P . Moreover, since r can only face off once against c if it advances to path P , r wins against at least one other number $i < r$ in its branch off of P . In particular, in the tree $T' = \pi_{r+1} \circ \dots \circ \pi_n(T)$, the leaf edge r is still not attached to path P . Thus, in T' , leaves a and c are on the same branch from the perspective of r , so $z_c = 0$ by Corollary 2.3.

We now show that if $k_r > 2$, the coordinates of the point T satisfy the additional equations $z_1 = 0, z_2 = 0, \dots, z_{k_r-2} = 0$. Assume for contradiction that $z_\ell = 1$ for some $\ell \leq k_r - 2$. By Corollary 2.3, this means that in T' , the label r separates ℓ from a . By Lemma 5.1, r separates ℓ from a in T as well. Now, let v_r be the internal vertex adjacent to r , let T_ℓ be the branch from v_r containing ℓ , and let m be the smallest label T_ℓ . By Lemma 5.2, since T_ℓ does not contain a , we have that m labels all edges in its path to v_r except possibly the last edge (connecting to v_r). However, note that

$$m \leq \ell \leq k_r - 2 \leq r - 2 < r,$$

so m also advances to the final edge adjacent to v_r by the laziness principle.

It follows that r 's first round of the tournament is against some number $m \leq k_r - 2$. By the Winners and Losers Lemmas (3.6 and 3.7), r wins every round in which it competes. By Lemma 3.4, the losers (across the entire tournament) form a weakly decreasing sequence. Furthermore, r itself will never face the same opponent twice, and so the sequence of losers that r faces form a *strictly* decreasing sequence starting at m . Thus by the Participation Lemma (3.8), the maximum possible number of opponents r has is $m + 1$ (since $c, 1, 2, \dots, m$ may be its opponents, but not a or b). But $m + 1 \leq k_r - 1$, and so r wins at most $k_r - 1$ times, contradicting the fact that $T \in \text{Tour}(\mathbf{k})$.

Hence $z_\ell = 0$ as desired. □

Acknowledgements

We thank Renzo Cavalieri and Mark Shoemaker for helpful conversations pertaining to this work. We thank the referees for their valuable comments and suggestions, particularly regarding the exposition in the paper.

References

- [BM13] Jonas Bergström and Satoshi Minabe. On the cohomology of moduli spaces of (weighted) stable rational curves. *Mathematische Zeitschrift*, 275(3–4):1095–1108, 2013. doi:10.1007/s00209-013-1171-8.
- [BMPS19] Jonah Blasiak, Jennifer Morse, Anna Pun, and Daniel Summers. Catalan functions and k -Schur positivity. *J. Amer. Math. Soc.*, 32:921–963, 2019.

- [CCRL⁺20] Federico Castillo, Yairon Cid-Ruiz, Binglin Li, Jonathan Montaña, and Naizhen Zhang. When are multidegrees positive? *Adv. Math.*, 374:107382, 34, 2020. doi:10.1016/j.aim.2020.107382.
- [CDH⁺22] Emily Clader, Chiara Damiolini, Daoji Huang, Shiyue Li, and Rohini Ramadas. Permutohedral complexes and rational curves with cyclic action. *Manuscripta Math.*, 2022. doi:10.1007/s00229-022-01419-6.
- [CGM21] Renzo Cavalieri, Maria Gillespie, and Leonid Monin. Projective embeddings of $\overline{M}_{0,n}$ and parking functions. *Journal of Combinatorial Theory, Series A*, 182:105471, 2021.
- [CJ18] Emily Clader and Felix Janda. Pixton’s double ramification cycle relations. *Geometry and Topology*, 22(2):1069 – 1108, 2018. doi:10.2140/gt.2018.22.1069.
- [CL21] Samir Canning and Hannah Larson. The Chow rings of the moduli spaces of curves of genus 7, 8, and 9. Preprint, 2021. arXiv:2104.05820.
- [CLQ22] Emily Clader, Dante Luber, and Kyla Quillin. Boundary complexes of moduli spaces of curves in higher genus. *Proc. Amer. Math. Soc.*, 150(5):1837–1848, 2022. doi:10.1090/proc/15423.
- [CP21] Melody Chan and Nathan Pflueger. Euler characteristics of Brill-Noether varieties. *Trans. Amer. Math. Soc.*, 374(3):1513–1533, 2021. doi:10.1090/tran/8164.
- [DGT22] Chiara Damiolini, Angela Gibney, and Nicola Tarasca. Vertex algebras of CohFT-type. In *Facets of algebraic geometry. Vol. I*, volume 472 of *London Math. Soc. Lecture Note Ser.*, pages 164–189. Cambridge Univ. Press, Cambridge, 2022.
- [DM69] Pierre Deligne and David Mumford. The irreducibility of the space of curves of given genus. *Inst. Hautes Études Sci. Publ. Math.*, 36:75–109, 1969.
- [EH86] David Eisenbud and Joe Harris. Limit linear series: basic theory. *Invent. Math.*, 85(2):337–371, 1986. doi:10.1007/BF01389094.
- [EH16] David Eisenbud and Joe Harris. *3264 and All That: A second course in algebraic geometry*. Cambridge University Press, 2016.
- [Fry19] Andy Fry. Tropical moduli space of rational graphically stable curves. Preprint, 2019. arXiv:1910.00627.
- [Get95] Ezra Getzler. Operads and moduli spaces of genus 0 Riemann surfaces. In G.B.M. van der Geer R.H. Dijkgraaf, C.F. Faber, editor, *The Moduli Space of Curves*, volume 129 of *Progress in Mathematics*. Birkhäuser Boston, 1995. doi:10.1007/978-1-4612-4264-2_8.
- [GGL22a] Maria Gillespie, Sean T. Griffin, and Jake Levinson. Degenerations and multiplicity-free formulas for products of ψ and ω classes on $\overline{M}_{0,n}$. Preprint, 2022. arXiv:2201.07416.
- [GGL22b] Maria Gillespie, Sean T. Griffin, and Jake Levinson. A proof of a conjecture by Monin and Rana on equations defining $\overline{M}_{0,n}$. Preprint, 2022. arXiv:2209.06688.
- [GKM02] Angela Gibney, Sean Keel, and Ian Morrison. Towards the ample cone of $\overline{M}_{g,n}$. *J. Amer. Math. Soc.*, 15(2):273–294, 2002.

- [Hag93] James Haglund. *The q, t -Catalan Numbers and the Space of Diagonal Harmonics*, volume 10 of *University Lecture Series*. Amer. Math Soc., 1993.
- [Kap93] Mikhail M Kapranov. Veronese curves and Grothendieck-Knudsen moduli space $\overline{M}_{0,n}$. *J. Algebraic Geom.*, 2(2):239–262, 1993.
- [KM05] Allen Knutson and Ezra Miller. Gröbner geometry of Schubert polynomials. *Ann. of Math. (2)*, 161(3):1245–1318, 2005. doi:10.4007/annals.2005.161.1245.
- [KT09] Sean Keel and Jenia Tevelev. Equations for $\overline{M}_{0,n}$. *Int. J. Math.*, 20(09):1159–1184, 2009.
- [LLV20] Eric Larson, Hannah Larson, and Isabel Vogt. Global Brill–Noether Theory over the Hurwitz Space. Preprint, 2020. arXiv:2008.10765.
- [MR17] Leonid Monin and Julie Rana. Equations of $\overline{M}_{0,n}$. In *Combinatorial algebraic geometry*, volume 80 of *Fields Inst. Commun.*, pages 113–132. Fields Inst. Res. Math. Sci., Toronto, ON, 2017.
- [MS05] Ezra Miller and Bernd Sturmfels. *Combinatorial commutative algebra*, volume 227 of *Graduate Texts in Mathematics*. Springer-Verlag, New York, 2005.
- [Pix13] Aaron Pixton. *The tautological ring of the moduli space of curves*. PhD thesis, Princeton University, Princeton, NJ, 2013.
- [PP21] Rahul Pandharipande and Aaron Pixton. Relations in the tautological ring of the moduli space of curves. *Pure Appl. Math. Q.*, 17(2):717–771, 2021. doi:10.4310/PAMQ.2021.v17.n2.a7.
- [Rai06] Eric Rains. The action of S_n on the cohomology of $\overline{M}_{0,n}(\mathbb{R})$. *Selecta Mathematica - New Series*, 15, 01 2006.
- [RS22] Rohini Ramadas and Rob Silversmith. Two-dimensional cycle classes on $\overline{M}_{0,n}$. *Mathematische Zeitschrift*, 301(4):3713–3726, 2022. doi:10.1007/s00209-022-03031-6.
- [Sha19] Nand Sharma. Psi-class intersections on Hassett spaces for genus 0 with all weights $\frac{1}{2}$. *Rocky Mountain J. Math.*, 49(7):2297–2324, 2019. doi:10.1216/rmj-2019-49-7-2297.
- [Sil22] Rob Silversmith. Cross-ratio degrees and perfect matchings. *Proc. Amer. Math. Soc.*, 2022. doi:10.1090/proc/16016.
- [Wae78] Bartel L. Van Der Waerden. On varieties in multiple-projective spaces. *Indagationes Mathematicae (Proceedings)*, 81(1):303–312, 1978.