

UC Santa Barbara

Himalayan Linguistics

Title

Beyond evidentiality, the case of Ladakhi inok & siblings [HL Archive 13]

Permalink

<https://escholarship.org/uc/item/0tm2v2sr>

Journal

Himalayan Linguistics, 0(0)

Author

Zeisler, Bettina

Publication Date

2024-04-17

DOI

10.5070/H90051278

Copyright Information

Copyright 2024 by the author(s). This work is made available under the terms of a Creative Commons Attribution-NonCommercial-NoDerivatives License, available at <https://creativecommons.org/licenses/by-nc-nd/4.0/>

Peer reviewed

Himalayan Linguistics

A free refereed web journal and archive devoted to the study of the
languages of the Himalayas

Beyond evidentiality, the case of Ladakhi *inok* & siblings

Bettina Zeisler

Universität Tübingen

Himalayan Linguistics
Archive 13

Himalayan Linguistics Archive No. 13 i-ii, 1-152

ISSN 1544-7502

© 2023. All rights reserved

himalayan linguistics

A free refereed web journal and archive devoted to the study of the
languages of the Himalayas

Himalayan Linguistics

Beyond evidentiality, the case of Ladakhi inok & siblings

Bettina Zeisler

Universität Tübingen

ABSTRACT

The crosslinguistic concept of evidentiality, discriminating between direct and indirect knowledge, does not account for the Tibetic system, where the domain of direct is split up between *external* direct knowledge, based on immediate sense perception, and *internal* direct knowledge, based on acquaintance, control/ volition, responsibility, and/ or authority or active involvement.

With the so-called ‘factual’ copula and auxiliary *red* (or equivalents), several Tibetic languages also differentiate assertions, which are said to be neutral with respect to evidentiality. Ladakhi does not seem to have a corresponding counterpart. However, many ‘factual’ usages of *red* as a copula could possibly be translated by the compound auxiliary *inok* of the Central Ladakhi dialects and its siblings’ *hinak*, *hindak*, *hindak*, and *intsuk* elsewhere. Nevertheless, *inok* & siblings do not present events neutrally, but express a speaker’s distanced attitude towards the content *and* the addressee and, logically, express the expected attitude of the addressee in questions. One important function of *inok* & siblings is to shift the focus from the speaker and his or her knowledge to the addressee and the latter’s knowledge or interest. The exact value of this attitude may vary considerably according to the context and socio-pragmatic constraints, some of the latter also being dialect specific. The various functions of Ladakhi *inok* & siblings may shed light on the perhaps not so neutral character of *red* (and its equivalents) and, more generally, on how ‘evidential’ the ‘evidential’ systems in Tibetic languages (and languages under Tibetic influence) actually are.

KEYWORDS

Tibetic languages, Ladakhi, evidentiality, speaker attitude, ‘factual’ marker *red*, inferential, irrealis, social conventions

This is a contribution from *Himalayan Linguistics, Archive 13*.

ISSN 1544-7502

© 2023. All rights reserved.

This Portable Document Format (PDF) file may not be altered in any way.

CONTENTS

0	The structure of this study	1
1	General information	1
1.1	The ‘Ladakhi’ dialects	1
1.2	The data	3
1.3	Comparing the dialects	4
2	‘Evidentiality’ (a concept in need of qualification)	8
2.1	‘Evidentiality’ as a crosslinguistic concept	8
2.2	The socio-pragmatic dimension: speaker, addressee, and community	10
2.3	‘Evidential’ and ‘egophoric’ marking in Tibetic languages	12
2.4	‘Evidential’ marking in the Ladakhi dialects	14
2.5	‘Evidentiality’ and the use of <i>inok</i> and its dialectal counterparts	23
2.5.1	Comparability with the so-called ‘factual’ marker <i>red</i>	23
2.5.2	The various forms of <i>inok</i> & siblings	25
2.5.3	The existential counterpart	29
2.5.4	Overview of the functions of <i>inok</i> & siblings	31
3	The manifold usages of <i>inok</i> & siblings	35
3.1	Usages with an epistemic value	36
3.1.1	Inferences	36
3.1.2	Identification through sense perception	41
3.1.3	Sudden realisation: surprising situations or counter-expectations	45
3.1.4	Background identification and/ or shifted epistemic stance in narratives	48
3.1.5	Assumptions about future situations	57
3.2	Irrealis contexts	59
3.2.1	Conditioned assumptions about the future	59
3.2.2	Imagined situations: children’s play roles and stage directions	60
3.2.3	Imagining exemplary situations in explanations	62
3.2.4	Planning, suggesting, and explaining (profiling the interests of the addressee)	65
3.3	Socio-pragmatic factors and conventions	72
3.3.1	Profiling one’s own subjective relationship of distance or non-involvement	72
3.3.2	A matter of status and authority (profiling the addressee’s interests)	75
3.3.3	<i>Who am I? Who is this?</i> Talking gently to small children (profiling their knowledge state and the social interaction)	78
3.3.4	<i>Who was it?</i> Asking about the identity of an absent person (profiling the interests of the person who wants to know)	81
3.3.5	<i>It’s your own fault and you know it</i> (profiling the addressee’s expectable knowledge)	85
3.3.6	<i>It’s mine, not yours</i> (profiling the addressee’s relationship – to one’s own items)	87
3.3.7	Expressing one’s feeling of shyness or shame (profiling the addressee as being more competent or projecting the addressee as being much richer)	88
3.3.8	Lowering oneself in sarcastic usage (pretending to profile the addressee as being more competent)	90
3.3.9	Other usages concerning the speaker, carrying a special emotional load	92
3.4	Generalised or ‘factual’ usage	93
3.4.1	Shared observations (defocusing from one’s personal observation)	94
3.4.2	Shared activities	97
3.4.3	The explanatory mood: shared and shareable knowledge (profiling the addressee’s interests and knowledge)	98
3.4.4	‘Perfect’ facts: a developing generalised perfect construction (profiling the addressee’s interests and knowledge)	109
3.4.5	The Kenhat marker for de-personalised general knowledge <i>-anok</i> ~ <i>-anak</i> (profiling the addressee’s interests and knowledge)	120
3.4.6	Use of the DPG for first person habits and planned activities	124
3.4.7	Other usages for the speaker, carrying a special emotional load	126
4	Discussion	127
4.1	A note on origins	128
4.2	The socio-pragmatic functions	132
5	Conclusion	137
	Acknowledgements	142
	Abbreviations and conventions	143
	References	144

Beyond evidentiality, the case of Ladakhi inok & siblings

Bettina Zeisler

Universität Tübingen

अन्यद्धि व्युत्पत्तिनिमित्तम् अन्यच्च प्रवृत्तिनिमित्तम् ।

anyad dhi vyutpattinimittam anyac ca pravṛttinimittam.

Etymological meaning is one thing, usage another.

Mahimabhaṭṭa, *Vyaktiviveka*, Kashmir, 11th c. (ed. Śāstrī, p. 4, l. 8)

0 The structure of this study

The first section will give some general information about the dialects (1.1) and the data (1.2) and will discuss the comparability of the dialects and the forms in question (1.3).

The second section will deal in a more general way with the concept of ‘evidentiality’, which I think is in need of some qualification if it is to be applied for the Tibetic languages. I shall first comment upon the concept of ‘evidentiality’ as found in the crosslinguistic discussion (2.1). I shall then point to the necessity to account for the social dimension in the communicative situation, namely how speakers deal with potential knowledge asymmetries between speaker and hearer and with knowledge that is shared with a larger community (2.2). Subsequently, I shall briefly describe the system peculiar to the Tibetic languages (2.3). The next sub-section (2.4) will give an overview over the particular system shared by most Ladakhi dialects. Thereafter, I shall introduce the markers that are summarised here as *inok* & siblings and point to their potential functional similarity with the so-called ‘factual’ marker *red* of Central and Eastern Tibetan, inclusive the existential counterpart *yod.red* (2.5).

The third section will then deal with the various usages of *inok* & siblings according to the four broad categories of: usages that correspond to the original epistemic, inferential, and/ or admiring value of the form (3.1), irrealis usage (3.2), usages according to social conventions (3.3), and the most neutralised usages for explanations and generic knowledge (3.4).

The fourth section will provide a discussion of the findings and, in particular, a brief note on the origin of *inok* & siblings (4.1) and a recapitulation of their socio-pragmatic functions (4.2), before coming to the conclusion in the last section (5).

1 General information

1.1 The ‘Ladakhi’ dialects

‘Ladakhi’ is spoken in Ladakh, a former independent kingdom, until very recently constituting two districts (*tehsils*) of the state Jammu & Kashmir, in India. The two districts had been part of the Kashmir Division. As per February 8, 2019, Ladakh was finally granted a separate

Divisional Status besides the Divisions of Jammu and Kashmir, only to be turned into a Union Territory by declaration of August 5 2019 with effect from October 31, 2019.

As the initial quotes indicate, the name of the province is a misnomer and so is the designation for the language and its dialects. The designation *Ladaks* (or perhaps only *Lata*, see Zeisler 2010) originally referred merely to Leh and its surroundings. Via a Purikpa or Baltipa pronunciation as *Ladaχ(s)*, it yielded the Urdu spelling لداخ, and accordingly, the English rendering *Ladakh* (nowadays simply *Ladakh*). The Ladakhi dialects fall into three groups: 1. the Baltipa-Purikpa group with the dialects of Western and Southern Purik plus the Baltipa border dialects, 2. Shamskat ('Lower Language'), namely the dialects of Sham (Lower Ladakh), Ldumra (a.k.a. Nubra), and Eastern Purik, and 3. Kenhat ('Upper Language') with the dialects of Central Ladakh, Upper Indus (with the side-valley of Gya-Miru), Lalok ('behind the pass', i.e., the 'Changla' or Northern Pass), Zanskar, and the Tibetan border region. While the latter two groups are very similar in their evidential systems, despite the use of different markers, the Baltipa-Purikpa group displays a much less evolved system. However, with respect to case grammar and a few other particularities, the Baltipa-Purikpa group may be loosely associated with the Shamskat group.

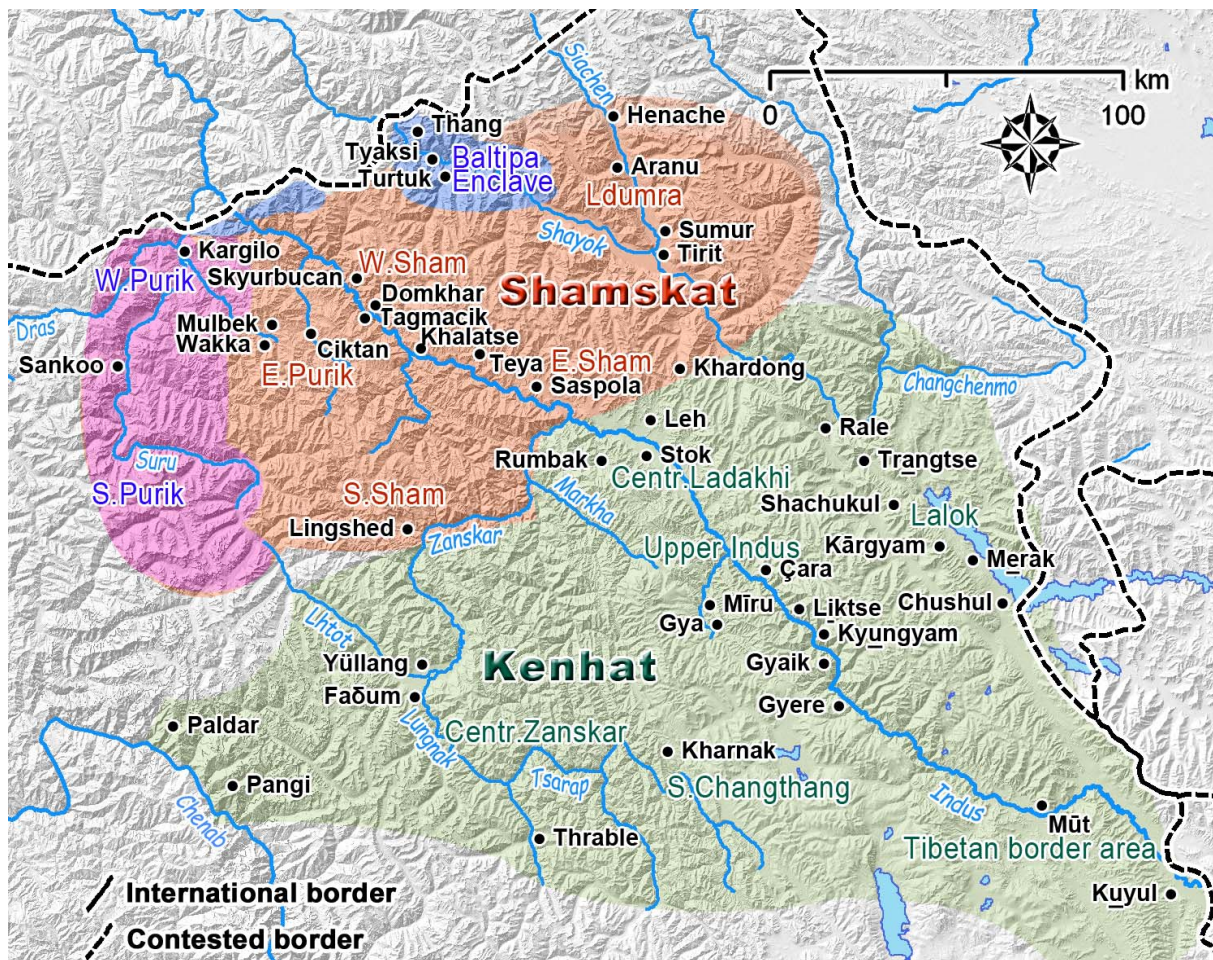

Figure 1 Dialect areas. Location of villages only approximate.
Background relief map: courtesy Quentin Devers.

The Shamskat and Kenhat groups differ not only on the phonological level (most of the Kenhat dialects being tonal,¹ the Shamskat and Baltipa-Purikpa dialects being rich in initial consonant clusters), but also, more fundamentally, in their case grammar. While the Shamskat and Baltipa-Purikpa dialects differentiate between an agent and a possessor (*khos* ~ *khoze* ~ *khosi* ‘s/he-ERG’ vs. *khoe* ~ *khwe* ‘s/he-GEN’), the Kenhat dialects do not (*khoe* ~ *khe*² ‘s/he-GEN/ERG’). The dialect groups also differ in their choice of markers for shared and shareable knowledge, inferences, estimations and/ or probabilities, and for mental distance, and in other minor issues, but these differences are usually rather gradual, e.g., certain Eastern Shamma dialects share a few of these markers with the Kenhat dialects. Some dialects sandwiched between the two groups may multiply some of their markers, e.g., the Lingshetpa dialect has three competing probability markers with hardly any difference in meaning.

It has been quite common to refer to the local dialects directly by the name of the village or region. Until recently, I have followed this convention, but being confronted with the term “Ladaks” instead of Ladakhi in a draft written by Nicolas Tournadre, I realised that this is a rather strange convention, as one would not talk about the England, France, or Germany language, nor of the Paris or München dialect, at least not in French or German. I have thus decided to use a common derivative suffix *-pa* (rarely assimilating to *-ma*), which indicates the belonging to something, hence, one has *rta-pa* ‘horse man’, *ladaks-pa* ‘a person belonging to Ladakh’ or also, in the Sham-ma and Purik-pa dialects: *ane-pa* ‘a group of women’, *sonam-pa* ‘Sonam and his or her family members’, etc. I will keep Ladakhi, however, as a well-introduced areal cover term.

1.2 *The data*

With the exception of the dialect of Kargil (locally known as Kargi-lo ‘the settlement of Kargi’), which has been described in detail by Zemp (2018), data from the village dialects plotted in the above Figure 1 have been collected by me. Some of the data have been observed through participatory observation, some through recordings. Most data, however, have been collected in intensive elicitation sessions with informants, most of them aged between twenty and forty, using an ever-growing questionnaire.³ Part of this data was collected for other research questions, and in those cases, the ‘evidential’ markers represent the informants’ spontaneous choices. It was only

¹ I shall mark only phonemic or contrastive register tone distinctions. Kenhat register tone is triggered by the syllable onset, but affects the whole syllable and is usually perceptible with the vowel. Contrastive tone distinctions only apply to the first syllable of an intonational unit (i.e., word). Subsequent syllables have a default high(er) tone. Contrastive tone distinctions further apply only to syllables with voiceless onsets and to syllables with sonorant onsets, that is, nasals, *j*, *l*, and *w*. Contrastive high tone results from originally (that is, Old Tibetan) voiceless, non-aspirated onsets, single or in clusters, contrastive low tone results from originally voiced initials, not ‘protected’ by any preceding cluster consonant. Sonorant plain initials are voiced and low tone by default, an originally preceding cluster consonant leads to a voiceless high tone realisation; the combination *dbV* leads to a high tone realisation *wV* or to a non-contrastive high tone glottal onset *ʔV*. The voiced vowel onset *hV* leads to a (non-contrastive) low tone realisation. Depending on the dialect, the copula *yin* may be realised either as *j̄in* (with contrastive low tone) or as *h̄in* (with non-contrastive low tone). Syllables with voiceless aspirated consonants may be described by Kenhat informants as having a non-contrastive neutral tone between high and low, syllables with voiced initials may be described as being lower than the low tone triggered by voiceless consonants, those with originally plain nasals may be described as having the lowest tone, see Bielmeier (1988); Zeisler (2011: 251–258).

² The Upper Indus dialects also use a syllabic marker /-se/ with nouns in open vowel other than pronouns, hence *ajme* ~ *ajmose* ‘Angmo-GEN/ERG’.

³ See <http://tulquest.huma-num.fr/sites/default/files/questionnaires/41/QuestionnaireEvidentiality.pdf> for an early version.

when I realised that these choices did not always match the unmarked basic pattern of the available descriptions (cf. Table 1, below p. 18), that I started to pay attention to these apparent idiosyncrasies and eventually developed a research project on the topic of *Evidentiality, epistemic modality, and speaker attitude in Ladakhi – Modality and the interface for semantics, pragmatics, and grammar*, funded by the German Research Foundation (DFG) for the years II/2016–I/2019 and VI/2022–V/2024.

In the elicitation sessions, I typically ask for the formulation of sentences in particular contexts, such as, e.g., private and official introductions, explanations, jokes, narrations, etc. Often, I also suggest sentences to be translated, sometimes requesting the informants to step into my shoes or at least to tell me how I should formulate the sentence, given that kind of knowledge and that kind of context. I further discuss phrases observed in my daily interactions, as well as data noted down from other informants or obtained through transcriptions. The informants are usually asked about the motivation or the possible background context for the choice of the respective markers, typically in contrast with other available markers. If a particular marker is not acceptable in a particular context, I also try to get a description of how wrong or crazy it feels and what exactly is wrong or what the informants would think how other people might react if they used this form in this context, etc. (cf. Bendix 1993 for similar elicitation methods). All this is very time consuming (which is also one of the minor reasons why these sessions are not recorded, the major one being privacy), and it was not possible to get a full survey for all village dialects.

Nearly complete data have been obtained from the Shamskat dialects of Ciktan (Eastern Purik) and Tagmacik (Western Sham) and from the Kenhat dialects of Rumbak (central Ladakh), Çara, Gyaik, Gyere, Gya-Miru (Upper Indus), and Pangi (Himachal). Considerable data have been further collected from the Baltipa dialects of the Turtuk area, the Shamskat dialects of Sumur (Ldumra), Domkhar (Western Sham), and Lingshet (Southern Sham), and the Kenhat dialects of Rale and Shachukul (Lalok), Kyungyam (Upper Indus), and Faðum (Central Zanskar), while in the remaining cases, the data are fragmentary or, in the case of Khardongpa, not fully reliable. Nevertheless, even the more fragmentary data corroborate the general outline.

Except for some drawings and some photographs, I did not use any special stimuli. Two or three times, I tried the *pear story* (a short video with sound, but no speech),⁴ but this yielded no result beyond the already known patterns and what I could find out by mere asking. Whatever new pattern or usage I was able to document, it was very often the result of a spontaneous choice by one of the informants in a more or less controlled setting, checked and re-checked with speakers of various dialects, or something I overheard in everyday interaction.

1.3 Comparing the dialects

One of the reviewers (Rev1) objects that I cannot, and thus should not try to, prove the functional similarity of two formally slightly different grammatical markers of two different dialect areas, namely Western Shamma *intsok* and Central Ladakhi *inok*, by showing that they appear in the same contexts with roughly the same specific epistemic or pragmatic meanings. More particularly, Rev1 claims: “that two varieties use different constructions in one and the same context is no evidence for the assumption that they mean the same” and that if “some varieties [...] use *intsuk* where others use *inok*, this must not be interpreted [...] as suggesting that *intsuk* and *inok* mean

⁴ See <http://pearstories.org/>.

the same (in all other contexts as well)”. Rev1 generously neglects the fact that the functional similarity of the markers is not only established for one single context, but practically for all contexts where these markers occur, and further that the markers in question show the same amount of potential meanings and the same kind of dependence on the particular context.

It may be self-understanding for most of the readers, but in view of the fundamental opposition by Rev1 it needs to be restated: the meaning of any given word, morpheme, or construction depends on its usage in its specific context, rather than on its form or origin, a principle asserted already in the 11th century by the Kashmirian poetician Mahimabhaṭṭa (see the initial motto). In other words: meaning *is* the usage of a word or construction within a speech community within a given context.⁵ Or in Wittgenstein’s (Philosophische Untersuchungen §43) own words: *Die Bedeutung eines Wortes ist sein Gebrauch in der Sprache*. Along a similar line, Binnick writes in a blog post,⁶

Meanings, like grammars, are epiphenomenal, constructs we abstract from actual usage to describe human behaviours. Words, phrases, sentences have no meanings outside of context. Semantics is abstracted from language in use—from pragmatics. So pragmatics is not dependent on semantics. It’s just the other way round.

Context is particularly relevant in cases of polysemy and polyfunctionality. If we talk about “Quark” in German, we have to know beforehand whether we talk about a dairy product or about elementary particles. In the latter case, it does not matter for the communication anymore that the word is based on an apparent nonce word from Finnegans wake, nor that it may have been an outdated word for ‘croak’ or that Joyce might have referred to the German word for curd cheese, which may also be used for the meaning ‘nonsense’.⁷ Nor would it matter that the German word is a West Slavonic loan (Huterer 2007: 229).

The more original meaning of *red*, the potential counterpart of *inok* & siblings, was ‘change, become, turn into’, see Denwood (1999: 246, with note 1 on p. 273) or perhaps only a resultative ‘have become’ as the 16th-c. *Li.ši gur.khañ* seems to indicate, describing the meaning with the stem II *grub* ‘be, get accomplished’ (Taube 1978: 174). The Tibetan-Tibetan-Chinese dictionary (Zhang 1993: 2720) gives the definition as 1. in the sense of ‘getting negatively affected/ change to the worse depending on (lit. by getting mixed with) outward or independent causes’ (*rkyen.gžan.dañ hdres.nas ma.ruñ.bar hgyur*), such as ‘getting wounded’ (*rma red.pa*), 2. as equivalent to *hgrig.pa* ‘be, become alright’ and *hgrub.pa* ‘get accomplished’, and 3. as Old Tibetan ‘to dry up (of trees)’. None of these meanings tells us anything about how *red* is used in the modern Tibetic languages.⁸

Since in Ladakhi, the word *jontan* is used for ‘education’, it does not matter anymore for the speakers (and a translator) that the original meaning in Classical Tibetan is ‘virtue’. When a Ladakhi

⁵ See for this definition [https://de.wikipedia.org/wiki/Bedeutung_\(Sprachphilosophie\)#Ansätze_zur_Bestimmung_des_Begriffs_„Bedeutung“](https://de.wikipedia.org/wiki/Bedeutung_(Sprachphilosophie)#Ansätze_zur_Bestimmung_des_Begriffs_„Bedeutung“).

⁶ <https://binnick.ca/2024/02/25/semantics-is-epiphenomenal/>, accessed Feb. 25, 2024.

⁷ See also <https://en.wikipedia.org/wiki/Quark#Etymology>.

⁸ At the very best, one may reconstruct how *red* became a copula. Elsewhere I venture the idea that it was the resultative meaning of ‘have become’ that developed into a copula ‘be’, possibly with a somewhat weaker pragmatic function, because someone who *has become*, say, a king or a beggar *is* a king or a beggar, but this ‘being’ may be different from that of having been king or beggar all one’s life. This subtle difference may or may not have been exploited for epistemic or pragmatic hedging (Zeisler 2022a: 52–53). However, the actual, synchronic usages of *red* do not depend on this particular history.

speaker uses the expression *nosein* ‘have bought’ as a statement concerning the addressee, the ordinary interpretation makes less sense, and we deal instead with a collocation for saying ‘this is your own fault’, see also section 3.3.5. Several informants remarked that the actual meaning of *inok* or one of its siblings “depends on the situation”, and then we went in circles and spirals around that black box of context, until we could establish its content.

The basic principles underlying the above paragraphs have been expressed even more radically by de Saussure (1916 [2000]: 116–117):

[L]a langue est un système de pures valeurs que rien ne détermine en dehors de l'état momentané de ses termes. [...] Aussi le linguiste qui veut comprendre cet état doit-il faire table rase de tout ce qui l'a produit et ignorer la diachronie. Il ne peut entrer dans la conscience des sujets parlants qu'en supprimant le passé.⁹

Without the contextual dependence of meaning, one could not compare the meanings of different words or grammatical forms across languages. If Rev1 were right and if one could not even compare slightly different forms from neighbouring dialects, such as *in-ok* and *in-ts-ok*, then how could one compare unrelated words, such as Baltipa *go* (< *hgro*) and Ladakhi *fha*, both with the meaning ‘go’, with their English counterpart or with any other counterpart that is supposed to have the same meaning of ‘moving by one’s own will and force’? How could one compare extended meanings, such as ‘pass (of time)’, ‘happen’, and ‘become, turn into’, which we find both in Baltipa and Ladakhi, but not necessarily in other languages? Could one still use the term ‘ergative’ for, say, both the Purikpa and the Kenhat dialects, not to speak of other ergative languages?

In order to be meaningful, words and constructions must also stand in contrast to other words and constructions for different meanings or functions, e.g., English *man* means ‘male human being’ only in contrast to *woman*, otherwise, it stands in contrast to *animal*. The interpretation of a grammatical marker, in particular, depends on its relationship to other grammatical markers and thus upon its specific functional slot within a paradigm.¹⁰ Nevertheless, when comparing different languages, these slots or the full paradigms do not need to be exactly congruent; they only need to be comparable. Otherwise, we could not talk about crosslinguistic grammatical categories, such as tense and aspect, or ‘evidentiality’, for that matter (see also Haspelmath 2007, 2020).

In the case of *inok* & siblings, we deal with closely related dialects. We further deal with forms that are closely related in their formal property, being composed of the copula *yin* and an element *-ok* ~ *-uk* (a derivation of the originally admirative marker *hdug*) plus an additional morpheme *-s-* (preceded by an epenthetic *t*) in the case of *intsok*~*in(t)suk*. Most importantly, whatever form *inok* & siblings take, they take the same functional slot within the ‘evidential’ paradigm as opposed to a) the slots of the ‘evidential’ markers for ego-centred and for perceptive knowledge and b) to the other markers with more epistemic values (even if the latter markers may have a slightly different functional distribution, cf. Table 3 and Table 4 in section 2.4). There could be hardly any better functional correspondence between morphemes of different form from different dialects or languages than between the various instantiations of *inok* & siblings.

⁹ ‘[L]anguage is a system of pure values which are determined by nothing except the momentary arrangement of its terms. [...] That is why the linguist who wishes to understand a state must discard all knowledge of everything that produced it and ignore diachrony. He can enter the mind of speakers only by completely suppressing the past.’ (English translation, de Saussure 1959: 80–81).

¹⁰ I take this to be common knowledge. Nevertheless, see de Saussure (1916 [2000]: 159–166; 1959: 114–120).

As the following study aims to show, in almost all of the Ladakhi dialects, the different realisations of *inok* & siblings do not have one single unified meaning that may or may not differ from dialect to dialect. Instead, all of them have various context specific meanings; and they yield roughly the same *specific* epistemic-‘evidential’ or socio-pragmatic meanings or connotations, not just in a few contexts, but also in all the various contexts where they occur. They are thus functionally fully equivalent. If one searches for the one meaning that may unify all these disparate usages, as Rev1 wants me to do for each form separately, then it may be called epistemic and/ or pragmatic downgrading of one’s communicative stance. Other scholars might be tempted to conclude that *inok* & siblings are devoid of any epistemic or ‘evidential’ meaning and may thus treat them as ‘evidentially neutral’. This would be correct in so far one can find many commonalities with the so-called ‘evidentially neutral’ ‘factual’ markers *red* and *yod.red* (or their particular counterparts) in various modern Tibetic languages. However, I should think that the notions of ‘neutrality’ and ‘factuality’ do neither apply to *inok* & siblings nor to the so-called ‘factual’ markers of other modern Tibetic languages. While the ‘evidential’ or perhaps more epistemic functions of these markers tend to bleach out in the conventionalised socio-pragmatic usages, they still remain evident in other contexts. This holds both for *inok* & siblings and for the so-called ‘factual markers’.

I should like to add without exaggeration and conceit that so far, I have identified more contexts for *inok* & siblings than anybody else did for any of the ‘evidential’, epistemic, or ‘factual’ markers in the Tibetic languages, by paying special attention to *les paroles*, rather than to the idealised systematicity of *la langue*. Whether all my analyses will hold or not, our understanding of the ‘evidential’ system of the Tibetic type would be greatly enhanced, if other researchers were inspired by the list of contexts to check at least some of these contexts in other Tibetic languages.

While there can be some functional overlap between *inok* & siblings and other Ladakhi ‘evidential’ or epistemic markers, none of the latter and no complex construction other than with *inok* & siblings has a similar multitude of functions, and none of them shows all the pragmatic functions described in sections 3.3 and 3.4. This allows to treat all instances of *inok* & siblings as functionally equivalent compound forms and to use the same descriptive terminology.

By contrast, to call the element *-sok* of *in-tsok* an inferential marker and the element *-ok* of *in-ok* a generic or, as suggested by Rev1, a visual marker, and to ignore that both elements have fused with the copula to yield meanings beyond their epistemic values, would be utterly misleading. The notion of a ‘generalised evaluative (or epistemic) marker’ should be broad enough to cover all epistemic and pragmatic functions to be described. (For the notion of ‘evaluative’ markers see p. 16 with n. 16 below.)

Some commentators (anonymous and not so anonymous) have suggested that the diversity of forms is confusing, and that I should instead discuss this issue for each dialect separately, and, of course, give a full description for all the forms appearing in each dialect. This would be unnecessarily repetitious, and it would prevent the immediate comparability of the examples in question, separated by dozens of pages. I should like to request all readers to ignore the diversity of forms, rely on the glossing, and just concentrate on the examples in their context.

The individual dialects certainly differ somewhat in whether the particular sibling appears in all contexts, inclusive the more marginal ones, or whether it appears ‘only’ in the majority of all contexts. A greater divergence, that is, a much more restricted usage of the form in question, is found only in the dialects at the western and southern periphery, namely in the dialects of Pangi, the Turtuk area, and Purik. In the remaining greater part of Ladakh, the great functional similarity certainly derives from the dense social network between speakers from all regions. The differences

between the main Ladakhi dialects, on the one hand, and the Purikpa dialects, on the other, are thus also indicative of a greater social distance on the part of the Purikpa speakers (and this holds even more so for the Pangipa speakers and the speakers of the Baltipa dialects in Ladakh, not to speak about those in Baltistan). The difference between the peripheral and the main Ladakhi dialects also opens up a window onto the development of the markers in question. If not anything else, this certainly justifies to include the peripheral dialects, see also section 4.1.

2 ‘Evidentiality’ (a concept in need of qualification)

2.1 ‘Evidentiality’ as a crosslinguistic concept

The crosslinguistic concept of ‘evidentiality’ is defined as the marking of *sources of information* (see Aikhenvald 2015: 239) or sources of knowledge. Most scholars discriminate between ‘direct’ and ‘indirect’ sources, that is, ‘direct’ sense perception vs. ‘indirect’ hearsay *and* inferences.

I find this crosslinguistic notion of ‘indirect information’ extremely problematic, as it mixes up internal and external sources. When talking of *information* sources, the notion of ‘direct’ and ‘indirect’ can only refer to personal vs. second-hand information (cf. also Peterson 2000). Technically speaking, information comes either directly from the sender or indirectly via the sender from another source. First-hand information should thus comprise everything one has experienced oneself, through one’s agency, witnessing (cf. Plungian 2010: 29, 37 and *passim*), or reasoning, cf. Stenzel (2008) for the last point. Indirect information should be everything that another person or authority communicated.

The currently dominant concept, as represented by Aikhenvald (2015), where hearsay and inference are merged, is certainly derived from languages where hearsay and inferences are both associated with a weaker epistemic force. However, hearsay report or second-hand information first of all refers to a *source* of knowledge other than the speaker him/herself. Hearsay or second-hand information also differs from all other evidentials in that it allows non-commitment to the veracity of the content of the reported utterance (Maier 2019: 202), calling it a lie in the extreme case.¹¹ Indian philosophers of language have further observed that perceptions and (pre-verbal) inferences are unstructured, ambiguous, or holistic, that is, we simultaneously see a cat on the mat and a mat under the cat. Similarly upon seeing smoke on a hill (or a hill under smoke), we may vaguely locate the fire at or on the hill and at the same time associate the hill with fire. It is ‘only’ when conceptualising the situation verbally, one has to decide about the focus or perspective. Testimony or second-hand information, by contrast, is necessarily structured – or perhaps one should say: perspectivalised and selective. The speaker has chosen between *the cat on the mat* and, less likely, *the mat under the cat* or between *a fire being located on the hill* and *a hill having fire* (Matilal 1990 [2001]: 69). One may argue that a speaker’s ‘choice’ is already conditioned by the context, and so is no choice at all, but the addressee is in any case presented with a fixed structure or perspective. The imagination

¹¹ It is generally accepted that a sentence marked as direct ‘it is raining (I see)’ cannot be hedged with the remark ‘but I don’t believe it’ or even cancelled with the remark, ‘but it is not raining’ (Maier 2019: 201f.). Similarly, a conclusion of the ‘must’-type could not be hedged in this manner in various languages (Tantucci 2016: 197). According to the crosslinguistic perspective, the speaker would be committed to the truth of the proposition. In real life, speakers may well take a contradictory stance, doubting what s/he sees or infers, sometimes with very good reasons. But these are exceptional cases. By contrast, the content of second-hand reports, especially those of the indirect quotation type, can easily be doubted or contradicted, while the speaker remains committed to the fact that s/he perceived the utterance in question.

of the addressee is automatically led into one direction, and the choice between one and the other structure or perspective is no longer his or hers.

Inferences, guesses, and the like are made by the speaker based on his/her personal knowledge state, which again can have quite different inputs, hearsay being one of them. The epistemic authority lies with the speaker, in the case of inferences and assumptions, but with another person, in the case of hearsay and quotation. Only in relation to immediate perception is inference somewhat less direct or less immediate, but then it is a question of knowledge *types*, not of sources.

That inferences, just like guesses, might not exactly constitute a *source* of information, becomes apparent also from the work of other scholars. Brugman & Macaulay (2015: 206), e.g., suggest to treat inference or reasoning not as a *source* of evidence but as a mental *process* based on evidence. However, one might say that the result of this mental process leads to a different *type* of *knowledge*. According to Palmer (1996 [2001]: 8), inferences (deduction) would belong to the epistemic subsystem of modality together with assumption and speculation. It would follow then that as far as markers and expressions of inference and second-hand knowledge are seen as conveying less certain information, this is a question of epistemic modality, not of evidentiality. The ongoing debate on whether evidentiality is only a subfunction of epistemic modality or an independent semantic or grammatical category, may be the result of the intermediate position of hearsay as a potentially legitimate instance of evidentiality and a potential legitimate instance of epistemic modality and the likewise intermediate position of inference as a type of personal knowledge and a type of epistemic hedging and thus a legitimate instance of epistemic modality as well.

Immediate sense perception, on the other hand, also implies some usually unnoticed mental process of matching the perception with what one already knows, and the difference between immediate recognition of a situation through sense perception, say, when observing a person leaving the house, and inferences based on immediate sensual input, say, when seeing that hat and jacket of a person are gone, is only gradual. This is by no means a new insight. Hill (2012: 409) points to the sensual input of basic inferences, claiming that the inferential function of a “Lhasa” Tibetan perfect construction with the experiential auxiliary *hdug* merely “is a consequence of combining the evidential meaning of direct witness with the perfect tense”. Hill (2017) elaborates this point, arguing that (non-hedging) inference should be seen as a subtype of sensual direct evidence. Quite recently, Nicolas Tournadre re-emphasised the graduality between sense perception and inference based on sense perception in his talk at the online conference *Evidentiality and Modality: At the crossroads of grammar and lexicon*, Montpellier, 10-11th June 2021. To a certain extent, this graduality between immediate perception and inferences based on immediate sensory input is reflected in the Ladakhi dialects through the set of available markers and by the speakers’ individual choices.

It is also not self-understanding that immediate inferences or more complex types of reasoning yield less certain knowledge than singular sense perceptions do. The philosophers Al-Ghazali and Descartes were certainly of the opposite opinion, when they pointed to the fact that the perceived moon appears to have only the size of a shilling (or, say, a small disc), but the mathematical, i.e., inferential, operation shows us that it is of a very different dimension.

Similarly, quotation is not necessarily a matter of uncertainty. The Ladakhi quote marker, e.g., is quite similar to markers of ‘direct’ evidence as it presents the content as immediately perceived, without judging the truth-values or the social adequacy of the reported content, while the markers for inferences can have a slight connotation of uncertainty, although usually not of hedging. Even more importantly, in Ladakhi and other Tibetic languages, quote markers scope over all other ‘evidential’ and evaluative markers, as well as over illocutionary force.

Hence, one should better differentiate between *sources* of information (first-hand vs. second-hand or non-first-hand) and different *access channels* (visual vs. non-visual vs. inferences or non-witnessed), cf. Oisel (2013: 31f.), and avoid the term ‘indirect’ with reference to both inferences or assumptions and hearsay. Alternatively, one could differentiate between witnessed content and unwitnessed content (cf. de Haan 2012a: 1024, 2012b: 4), and in this case, inferences or assumptions and hearsay can be grouped together.

2.2 *The socio-pragmatic dimension: speaker, addressee, and community*

What is usually overlooked in typology and formal linguistics with respect to ‘evidentiality’ is that human communication is not just a transfer of information from sender to receiver, but a social interaction – not only between speaker and hearer, but also within a speech community – framed by various socio-pragmatic conditions and factors, such as status and politeness. The possibly most important of these conditions is the *right* to claim a piece of knowledge as (exclusively) personal knowledge and the question of how to deal with knowledge that one cannot claim as (exclusively) personal. This is not only a matter of what the speaker knows and what the addressee may or may not know, but also what is or could be more generally known by other people.

Kamio (1997) formulated the idea of *territories of information* (see more recently also Heritage 2012: 4). Corresponding socio-pragmatic notions of *epistemic authority* or *rights to know* and *rights to tell* have been formulated so far mainly in conversation analysis cf., e.g., Stivers et al. (2011) or Heritage (2012). These analyses are mostly concerned with turn-taking in (English) dialogs via short comments or various types of short questions, not with grammatical markers of evidentiality or epistemic modality. But the notion of epistemic authority has come to be applied also for grammatical epistemic systems in lesser known languages, where the question who knows or is expected to know and who not plays an important role, see Grzech (2016) for the Quechuan language Tiwa/Upper Napo Kichwa, and, more recently, Honkasalo (2019) for the Tibeto-Burman language Geshiza. It has further been observed for some Arawakan languages that evidential strategies, such as quoting, may be used to negate epistemic commitment and responsibility for the reported situation, while admitting direct observation may not only indicate highest epistemic commitment, but also responsibility for the reported situation (see Michael 2020), possibly because of involvement in that situation.

I should like to discuss ‘evidentiality’ in a broader perspective, with much longer, often only implied, ‘turns’. With respect to the use of ‘evidential’ markers, I hold that in Ladakhi, a speaker’s epistemic authority is highest when talking about his/her own actions or when talking to outsiders about things in his/her personal sphere or territory of information, and the speaker’s commitment is highest when talking without any reservation about these situations. While it is possible to “commit yourself *to some extent*” without claiming exclusive knowledge, as the second reviewer (Rev2) opines, ‘to some extent’ is not the same as the full commitment expressed by the so-called ‘egophoric’ markers. A speaker’s epistemic authority is considerably lower in cases of limited sense perception, inferences, or assumptions, and by marking these types of access his or her displayed commitment is likewise lower. Both epistemic authority and displayed commitment are the lowest, when transgressing into territories of information that belong to others and when dealing with shared or shareable knowledge, that is, when talking about facts the addressee is expected to know, but also when explaining something to someone who does not yet know, but wants to know or is

obliged to learn. This latter socio-pragmatic condition applies particularly to formal settings, such as teaching or giving a public talk.

The concept of mutual knowledge, that is, “any assertion which the speaker assumes is held in common with the addressee(s)” seems to have been first introduced by Hintz & Hintz (2014/2017). In a discussion after a talk at the conference *The Nature of Evidentiality 2012*, Leiden University, one of the two, if I remember correctly, Diane M. Hintz, mentioned that their concept of mutual knowledge would also include assertions of facts the addressee does not know yet, in which case, the assertion should be seen as an invitation to share the speaker’s or the whole community’s knowledge. This idea of an invitation underlies my notion of *shareable* knowledge.

To be precise, all knowledge is shareable, and if shared, it becomes mutual knowledge. But the point is, if I, the speaker, share some private information about me or people in my personal sphere with you, the addressee, then this information remains my private information and I still retain the exclusive rights to claim this as personal knowledge or as belonging to my territory of information. You, the addressee, only obtain the licence to present the facts as second-hand information or as an assumption – at least as long as you do not know me and the facts more intimately. What is licensed is the information content, but not the right of presenting it as personal knowledge.

Shared or shareable knowledge, on the other hand, especially knowledge about generic facts, is nobody’s personal knowledge, and marking it as shared or shareable is like presenting the facts under an open public license. I, the speaker, do not claim the information as being personal knowledge, and you, the addressee, are free to spread the information under the same conditions, that is, either as shared knowledge or as hearsay. Knowledge that is shared only between you and me and perhaps a few other people will likewise go under an open license, which, however, may be adapted to the needs of the communicative situation. Talking under such an open license will make my statements more distanced and less committed, and on the formal side, the facts will be presented in a down-graded mode of hedging *as if* I were not 100% certain about them.

It should be noted that my use of “committed” differs from recent usage elsewhere in linguistics, where the word is used in the sense that a speaker makes an epistemic evaluation in terms of truth-values and is then ‘committed’ to this evaluation (see, e.g., Nuyts 2001: 384f.). One may call this the *commitment to one’s epistemic validation*. This type of commitment does not seem to be gradable. However, it seems related to, and might be derived from, an earlier use of the term, indicating that by using different epistemic markers, a speaker is or is not committed in various degrees to the truth or factuality of his/her statement.¹² One might call this *epistemic commitment to veracity* or ‘validation’ (for this latter term see Floyd 1999). What I want to refer to with the likewise gradable notion of ‘commitment’ and ‘non-commitment’ is the pragmatic, intersubjective stance or attitude the speaker takes towards the content of his or her statement and towards the addressee. Even if the statement is believed to be true, one can either identify with it or even vouch for it (high commitment) or, by contrast, attenuate it and keep it at a certain distance (non-commitment or less-committed, should anyone prefer) for quite different reasons, among which not the least is the perceived absence of the right to speak with personal authority. This type could then be called *commitment to content and one’s epistemic rights* to present the information in a certain manner.

¹² With respect to English, strongest commitment would be expressed by the ‘must’ inferential, indicating the only possible conclusion or judgement, while a weaker commitment with the ‘will’ assumptive would be based on what is usually the case, and the weakest commitment would be a speculation with ‘may’ or ‘might’, as proposed in the oft-cited work of Palmer (cf. Palmer 1996 [2001]: 24f.).

This notion of ‘commitment’ is comparable to the notion of “confirmativity” as used by Friedman (1981, 2000) for the Balkan languages, but adds the notion of epistemic rights. The latter socio-pragmatic aspect may also be covered by the term ‘engagement’ as recently introduced, cf. Bergqvist & Kittilä (2017).

2.3 *‘Evidential’ and ‘egophoric’ marking in Tibetic languages*

Apart from the socio-pragmatic dimension, the traditional and still current evidential distinctions almost always omit one important base of knowledge, namely knowledge about what I, the speaker, know about myself plus possibly what I know about all that belongs to my personal (or cultural) sphere or to my territory of information. It may be noted that already Kamio (1997: 179–181), based on DeLancey (1986), assumes that the Lhasa Tibetan distinction between *yod* and *hdug* reflects the speaker’s position within and outside his or her own territory of information.

This lived self-experience, which has also been described in terms of ‘privileged access’ (see Garrett 2001: 16) or more frequently, although less suitably, as ‘egophoricity’, differs considerably from other observations and is, of course, the most direct knowledge one could ever have (cf. also Sun 2018: 54). One could argue with Wittgenstein that this kind of immediate ‘knowing’ is not knowledge, belief, or certainty in any meaningful (philosophical or psychological) sense, not even the absence of doubt, just because it does not come with the connotation that there might be a possibility of doubt or the necessity of justification by reasoning or experiments (I draw this argument from Malcom (1991), who refers to Wittgenstein’s essay *On certainty*). The content from such ‘knowing’ is beyond doubt or simply *not at issue* or with this marvellous German word: *unhintergebar*. The special features of this type of knowledge have to be taken into account in order to better understand what may be implied by the terms ‘evidential’, ‘egophoric’, and ‘factual’ or also ‘speaker attitude’ with respect to the Tibetic languages.

My use of being or not being “at issue” differs from Formal Semantics, where the notion “not at issue” refers to shared knowledge or the common ground of presuppositions. Nevertheless, the notion of being or not being *at-issue* has been handled from different perspectives. Murray, e.g., suggests using the attribute ‘not-at-issue’ with respect to evidential markers. In her dissertation, Murray (2010: ii) states that the Cheyenne “evidentials contribute not-at-issue content, which cannot be directly challenged or denied. This content is added directly to the common ground, without negotiation. In contrast, at-issue content, the main point of a sentence, is proposed to the common ground, up for negotiation”.

Somewhat differently, my usage here refers to the speaker’s personal attitude and his or her presentation of facts, i.e., the content, as being or not being open to debate, independent of the question whether the facts can be presupposed or not. That is, the focus is not on the stance that may or may not be at issue but, depending on the stance taken, it is the *content* or *the main point* of the utterance that is or is not at issue. Hence when using the so-called ‘egophoric’ markers or the Set 1 markers of Table 1 below, the *content* or *main point* is added directly to the common ground without being negotiable. When using other markers, the *content* or *main point* is presented as being more or less negotiable. The *content* or *main point* is certainly somewhat less negotiable when using markers for perception and inference and more so when using epistemic markers, indicating a certain amount of uncertainty, while the content will be highly negotiable when using *inok* & siblings.

Typically, presuppositions are presented by Ladakhi and Tibetan speakers in a highly non-committed stance as being at issue or as open for debate and questions about further details. By

contrast, ‘my’ (the Ladakhi speaker’s) ‘not-at-issue’ statement signals that ‘you’ the addressee have to accept what I say, because I speak about my own deeds or from exclusive personal acquaintance or because I have non-challengeable, exclusive authority or responsibility. This piece of information ‘belongs to me’, so to speak, and that is why it is not at issue for ‘you’.

It is generally accepted that ‘evidential’ markers of the Tibetic type cannot be negated, that is, except for the semi-lexical quote marker *lo* in the western varieties, negation of an evidential auxiliary always scopes over the lexical verb. Nevertheless, the *attitude* of having *not-at-issue* knowledge can be challenged. Any interlocutor can hark back: *How do you know?* or even: *How can you dare to claim authority or privileged access?* In other words: the *right* to make a not-at-issue statement *is* at issue.¹³

No other attitude can be challenged like the attitude of having privileged access or epistemic authority. The *attitude* that goes along with the presentation of facts as merely perceived, and especially as being merely inferred or guessed is not at issue, just because it is an attitude of non-commitment. Inferences and guessings cannot be challenged as such, even though their reported content might be objectively wrong. It does not make much sense to say: *You didn’t infer, assume, or guess it (that way)*. One could only challenge the inherent logic. The only way to challenge the attitude of having observed a situation personally is to challenge the presumed presence in the situation: *You didn’t see or hear it, because you were not there*. This simply amounts to telling the person that s/he is a liar, a challenge that is independent of the presentation mode, hence it does not challenge the speaker’s attitude. Such challenges would be rare, anyway, because the opponent’s absence from the reported situation is, in most cases, difficult to establish. What could be challenged, at least theoretically, is the private character of perceptions: *How can you pretend that only you saw it, I was there, as well?*¹⁴

In my opinion, these two attitudes: *content at issue* (because of low epistemic authority or mental distance) and *content not at issue* (because of privileged access and identification with the situation, and thus highest epistemic authority and commitment) form the fundamental opposition of what is usually described as an ‘evidential’ system in the Tibetic languages, at least so in Ladakhi. I would thus argue that the auxiliary system in Ladakhi, and possibly also more generally in Tibetic (and similar) languages, is not so much, or not only, about access channels, but also, or perhaps dominantly, about the speaker’s attitude of personal commitment or non-commitment and about what has been described recently as intersubjectivity or engagement (see, e.g., Evans, Bergqvist, and San Roque 2018a/b).

The question of whether one presents a certain situation as at issue or not is also a question of the above-mentioned socio-pragmatic factors in the communicative interaction. It has to do, on the one hand, with one’s rights to exclusive knowledge and, on the other hand, with one’s respect for the addressee’s knowledge and interest. The traditional evidential and epistemic categories are then sub-categories of the non-committed stance for *content at issue*, see Figure 2.

¹³ I remember that the only time that I was corrected in quite a harsh tone was when I used the *not-at-issue* marker *yod* for something I thought to be generally known, namely the dense vegetation in the lower parts of the Kargil district. But for such shared knowledge, I should have used quite a different marker, with *inok* & siblings being one option. Since it was about a place that I just visited for a very short period and since that place also did not belong to my personal sphere, nor to that of the addressee, I actually should have used the visual marker *hdug*.

¹⁴ Interestingly enough, as has been pointed out to me by Nicolas Tournadre (p.c. September 2019), in certain communicative situations, when talking about weather and food, the marker for visual sense perception is preferred for shared observations. In such cases, only the non-visual marker points to personal observations.

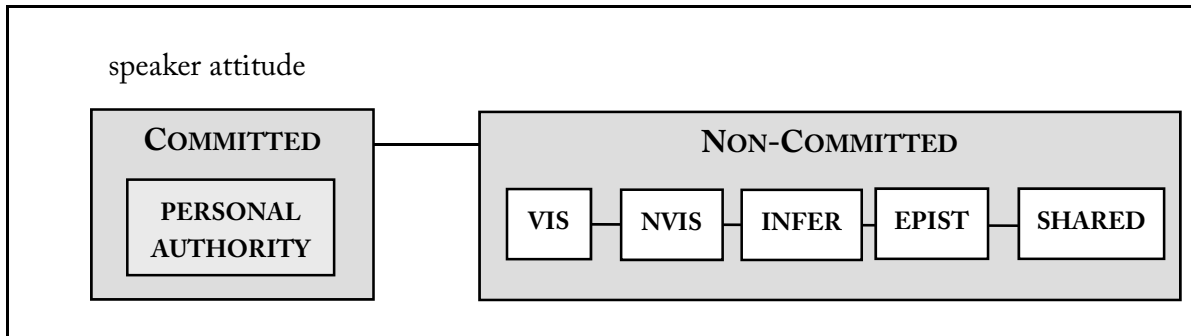

Figure 2 The layered system of speaker attitude in Ladakhi

A layered structure, comparable to Figure 2, is also proposed by Widmer (2020, especially p. 262, Fig. 9.1) for Bunan, see here Figure 3.

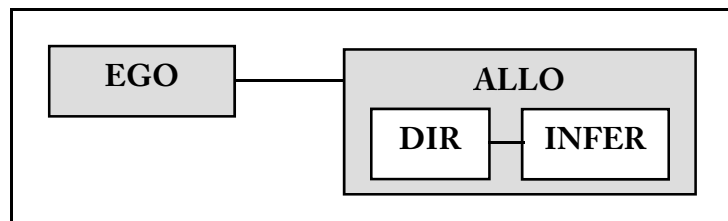

Figure 3 Widmer's (2020) layered system for Bunan

With respect to the Amdowa dialects, Tribur (2019: 126–127) argues along quite similar lines for a non-inclusion of ‘egophoricity’ within ‘evidentiality’. Although she calls herself agnostic with respect to how the overarching principle should be called, she thinks that both ‘egophoricity’ and ‘evidentiality’ may be part of a larger epistemic system.

2.4 *Evidential’ marking in the Ladakhi dialects*

Like in most other Tibetic languages, the Ladakhi markers for self-centred, committed, or authoritative knowledge are the plain (i.e., suffixless) indentificatory linking verb or COPULA *yin* (negated *man ~ men*) and the plain EXISTENTIAL LINKING VERB *yod* (negated *med*). (Please note that I will not treat the latter as ‘copula’, if only for better differentiating the functions of the two linking verbs.) The main function of the copula in most Ladakhi dialects is to establish a relation of identity. In the Kenhat dialects, the copula is not commonly used for attributes, while most Shamskat dialects allow the copula besides the existential linking verb for attributes. Where copula and existential linking verb are used side by side for attributes, the copula tends to refer to a present or close situation and/or expresses a more general and objective state of affairs, while the existential linking verb tends to refer to a more distant situation and/ or expresses a more subjective view. Additionally, the copula may indicate personal attachment and/ or more recent knowledge, while the existential linking verb may indicate longer acquaintance. Both the copula and the existential linking verb also appear as auxiliaries in tense constructions. In these constructions, the copula usually refers to a temporally more limited situation, typically in sight or close by, while the existential linking verb refers to a temporally more expanded and/ or more general and/ or more distant situation.

Visual perception and non-visual perception are not discriminated in most Tibetic languages; the marker *hdug* (or an alternative marker, such as, e.g., *snaŋ*) is used for all kinds of (external)

perceptions. Apart from most Ladakhi dialects, non-visual perception receives a special marker only in a few more Western Tibetan dialects, such as Spiti (Bielmeier 2000: 110–113, Hein 2007: 198), and in a few Kham dialects, see, e.g., Suzuki (2017: 436–440) for Zhollam and Suzuki & al. (2021: 81–84) for Choswateng. See also Ebihara (2017) for an overview.

In all Ladakhi dialects, except those of the Baltipa-Purikpa group, *hdug* (or *snaŋ*) is typically used for visual perceptions, while non-visual perceptions, including internal sensations, are typically marked by *rag*, both markers functioning as existential linking verbs, attributive copulas, and as auxiliaries. I should think, however, that *hdug* (or *snaŋ*) and *rag* do not primarily discriminate different sensory channels, but rather between the most immediate and less immediate perceptions – and inferences (see Zeisler 2023). In neutral past tense (that is, other than imperfect), the distinction of visual and non-visual sense perception is again conflated, and the observed events are zero-marked (use of the mere verb stem). The bare stem still appears in quite a few neutral or non-evidential functions. In various Kenhat dialects, the bleached verb *soñ* may additionally be used for situations moving away, and in a few eastern-most dialects *byuñ* may additionally be used for situations moving towards the speaker. Unlike in Central Tibetan, these latter two markers are not obligatory, and have a more emphatic function, highlighting the speaker's affectedness.

Since perceptions always need some kind of unconscious mental processing and some kind of comparison with what one already has internalised or knows, and since they are thus only gradually different from inferences based on sense perceptions, it is not so surprising that Ladakhi speakers may use both *hdug* (or *snaŋ*) and *rag* for inferences that are closely tied to immediate perceptions, e.g., when inferring that a person has cold upon seeing him/her shivering or when locating an arming camp upon hearing what is specific for such a camp.

The Ladakhi (and Tibetic) perceptual markers further signal that one's statement is based only on a limited number of perceptions, perhaps even only a single perception. The knowledge that one obtains from a single perception or a limited number of perceptions is obviously less certain than knowledge that is based on longstanding repeated experience in one's personal sphere. One may compare limited perceptual knowledge to an experiment that cannot be replicated. Whatever the truth behind the earlier outcome, the scientific community will not accept the results. Due to distraction or other factors, sense perceptions may be utterly misleading. Furthermore, as mentioned above p. 10, certainty alone does not automatically yield the 'right' to make an authoritative assertion. Hence, using the markers for (limited) sense perception in Ladakhi (or other Tibetic languages) indicates that one has left one's or territory of information and thus is not fully committed.

The different status of sense perception in the Tibetic systems and in systems commonly known from the crosslinguistic discussion of evidentiality may be represented as in Figure 4. Note that facts and own activities are usually not treated in the crosslinguistic discussion as part of 'direct' information or knowledge, nor does the crosslinguistic conceptualisation of evidentiality account for shared and shareable knowledge. These fields are thus given here with shading. The broad vertical lines indicate the respective main oppositions.

Type/language	Direct assertive		Indirect hedging (\pm mirative connotations)		
crosslinguistic EVIDENTIALITY	(facts & own activities)	observed situations	inference		second hand information
Ladakhi/Tibetic type	own/ controlled activities assertive	limited observation	inference assumptions	second hand information	shared/ ^s -able knowledge
		(\pm admirative connotations ¹⁵)		(-admirative)	
	Authoritative committed		Non-authoritative non-committed		

Figure 4 Basic evidential oppositions in comparison

The Ladakhi dialects further have a large set of additional evaluative markers¹⁶ (EM), that is, constructions for general (i.e., shared and shareable or non-personal) knowledge, inferences, estimations and/ or probabilities, and for mental distance, with no, little, and strong hedging epistemic functions. These markers show a somewhat different distribution across the dialect regions, see Table 3, below p. 21, for a subset of these markers. In particular, the Shamskat marker *-suk/-sok* has a broader range than the Kenhat past ‘inferential’ marker *-tok/-tuk*. Shamskat *-suk/-sok* may be used for irrealis situations and counter-expectation. This is reflected in the chosen label ‘inferential-*cum*-distance marker’. Of particular interest may be the fact that this marker also appears in the Kenhat dialects, but only in its mirative function and, for some speakers only, in irrealis contexts. Accordingly, the Kenhat marker *-suk/-sok* will be labelled ‘mirative distance marker’.

Note that the term ‘inferential’, both in the label past ‘inferential marker’ and in the label ‘inferential-*cum*-distance marker’ is somewhat imprecise and used here only as a stopgap for lack of a better descriptive term. Koshal (1979: 216) describes the ‘past inferential’ *-tok* as “attested inferential”. According to her, it would be used when “one wants to talk about an action the occurrence he [!] has neither seen himself nor has any direct (first-hand) knowledge of, but which he can infer because he already has other kinds of evidence or proof”.

One might call this form a ‘non-eyewitness marker’ (cf. Volkart 2000: 128, Table 1 with ‘unwitnessed’ for Kagate), if only that description would not also apply to the distance markers and the quote marker. One might also call it an ‘indirect’ marker in the crosslinguistic sense, as it is also frequently used for unspecific hearsay information, but then again the notion of ‘indirect’ or ‘*médiatif*’ would apply also to the quote marker. Volkart (2000: 128, Table 1) describes most of

¹⁵ In Ladakhi, all verbal forms can have admirative overtones when used in a non-prototypical way. However, these overtones are more common with markers of inference and immediate sense perception than with the Set 1 markers, whose admirative usage is restricted to a few western dialects. Nothing can be said about other Tibetic languages.

¹⁶ The term ‘evaluative’ is also in use for diminutive, pejorative, and intensifying expressions. Simon & Hill (2015) would even include honorifics under this notion. However, while these ‘evaluative’ expressions rather *qualify* a situation, the evaluative markers, as the term is used here, indicate an *evaluation* in several respects of the content of the proposition, of one’s knowledge base, or of the different relationships that might hold between speaker and reported situation, speaker and addressee, and addressee and reported situation. According to de Haan (2005: 380), “epistemic modality *evaluates* the evidence” (italics as in the original), in terms of likelihood and veracity. Here, the notion of ‘evaluative markers’ includes markers of epistemic modality, but also markers that do not (necessarily) imply epistemic hedging, such as the inferential markers, the (mental) distance markers, and *inok* & siblings.

these forms as conveying uncertain knowledge, but the Ladakhi informants would usually insist that the forms *-tok/-tuk* and *-suk/-sok* are used for certain knowledge and only exceptionally may imply a slight degree of uncertainty. The inferential component is typically based on visual input. As far as unspecific hearsay is concerned, the Tagmacikpa informant described it as “my perception” (field data 2022), that is, the speaker regards it as his/her personal knowledge in contrast to the use of the quote marker or other *verba dicendi*, which shift the epistemic authority to somebody else.

Both forms *-tok/-tuk* and *-suk/-sok* refer to situations of the more recent past and, as far as the inferential component is concerned, to a more spontaneous becoming aware. For more complex processes of reasoning, for situations happening longer ago, and particularly for historical facts the Kenhat distance markers *-kjak*, *-ka(na)k*, Lingshetpa *-ka(no)k*, and the Shamskat and Purikpa complex distance marker *-kha((n)i)ntsok* are preferred. These distance markers combine a certain reservation or mental distance to the situation talked about with an epistemic connotation of lower certainty. This latter epistemic connotation may be due to the fact that the situation happened a long time ago or that it cannot be inferred immediately but only through putting the various pieces of evidence together. Competing with these, there may be alternative past or narrative distance markers, such as *-pintsok* or Kenhat *-kantsuk*, which tend to be restricted to traditional narrations. Distance markers can also appear in irrealis contexts. The function of the distance markers overlaps to a certain degree with that of the ‘inferential’ markers, but they usually reinforce the notion of non-commitment. See Table 3, p. 21 and Table 4, p. 22 for different inferential and distance markers, and Table 5, p. 22 for some examples.

Quotation and second-hand information is expressed in Ladakhi with the semi-grammaticalised marker *lo*, which shows a restricted verbal behaviour, that is, it can be negated and questioned, and may be used infrequently and without further marking as a lexical *verbum dicendi*. Like other Tibetic quote markers, *lo* as a quote marker follows the quoted utterance. The reported utterance keeps the ‘evidential’ or evaluative markers as well as the interlocutionary force and the local deixis, as in direct speech, while pronouns are usually shifted, the honorific grade is adapted, and intensifiers may be manipulated, as in indirect speech (for the shift of pronouns and honorific grade, cf. also Tournadre 2008: 301; Zemp 2013: 602). If lexical *verba dicendi* are used instead (e.g., when not having been directly addressed by the reported speaker or when reporting the words of a high-ranking person), the same rules apply. Unlike in the Standard European languages, the use of a quote marker does not imply any kind of hedging.

Since one’s statements are necessarily based on one’s particular knowledge and framed by one’s relevant attitude, information-seeking questions naturally have to take into account the knowledge base and possible attitude of the addressee: *what do you know, have seen, have heard, think is the case? Does John look like he is sick?* This speech act related perspectivising can also be observed in English modals, e.g., *Shall you attend the meeting? – Yes, I shall* (British English of the 1950s)¹⁷ or also *Might you go to the party? – I might (go)* (cf. Bergqvist & Kittilä 2017: 21). That is, information-seeking questions naturally target “the addressee’s assessment [...] not the speaker’s” (Bergqvist & Kittilä 2017: 21; see also recently Hill 2020: 201). Adverbs, such as *evidently*, *unfortunately*, or *honestly*, that would indicate the knowledge state, the evaluation, or the attitude of the speaker in a statement similarly target the addressee in questions (cf. Bruil 2015 with further references). There are, however, only few possibilities for projecting a downgraded stance in questions.

¹⁷ Ernest N. McCarus in a reply to a query by Mike Maxwell posted on the Linguist List 04 Jun 1999. <https://linguistlist.org/issues/10/10-856.html>. Accessed Mar. 16, 2017).

In the Tibetic languages including Ladakhi, this perspective shift in information-seeking questions leads to a by and large equal treatment of the speaker in statements and the addressee in information-seeking questions with respect to the use of ‘evidential’ and epistemic markers. Here, these two discourse roles of the speaker in statements and the addressee in information-seeking questions shall be comprised under the cover term “main speech act participant” (MSAP; cf. Agha 1993: 160, 166 for the notion of an “illocutionarily central”/ “focal speech-act participant”).

Other terms have been ‘locutor’ (Aikhenvald 2003 to 2015), ‘asserter’ (Creissels 2008), ‘informant’ (Bickel 2008), ‘speaking person’ (Sun 2018), ‘enunciator/ énonciateur’ or ‘perceiver’ (San Roque & Loughnane 2012). Unlike Zemp (2018: 535, n. 55), I should think that agent or person related terms should better be avoided as they may lead (and have led) to misunderstandings. Impersonal terms, such as ‘epistemic source’ (Hargreaves 2005, 2017) or also ‘(privileged) epistemic authority’ (Hargreaves 2017; cf. also his definition of ‘epistemic ‘evaluation’ p. 102, n. 3 and ‘epistemic source’, p. 102, n. 4), *origo*, or perhaps also ‘deictic centre’ (遠離指示中心, Shao 2016: 6), are certainly preferable, while the term that I have decided for in my works might be more illustrative for the communicative situation, the role-character, and the perspective switch in information-seeking questions.

verbal domain	Set 1: MSAP authoritative	Set 2: OTHER directly observed	
		visual	non-visual
identifying (LV)	<i>yin</i>		— ¹⁸
future (Aux)	<i>yin, zero</i>		—
attributive (LV)	<i>yin / yod</i> ¹⁹	<i>ɣdug (/ snaŋ)</i> ²⁰	<i>rag</i>
existential (LV)	<i>yod</i>	<i>ɣdug (/ snaŋ)</i>	<i>rag</i>
simultaneous (Aux) ²¹	<i>yod (/ yin)</i> ²²	<i>ɣdug (/ snaŋ)</i>	<i>rag</i>
perfect/ resultative ²³ (Aux)	<i>yod / yin</i> ²⁴	<i>ɣdug (/ snaŋ)</i>	<i>rag</i>
prospective (Aux)	<i>yod / yin</i>	<i>ɣdug (/ snaŋ)</i>	<i>rag</i>
past/ anterior (Aux)	<i>pa.yin</i>	<i>zero</i> ²⁵ , (<i>soŋ, (byuŋ)</i>) ²⁶	
all verbal domains		evaluative markers: <i>yin, yod</i> , stem, GRD & EM quotation: <i>lo</i> , other <i>verba dicendi</i>	

Table 1 The unmarked distribution of Ladakhi linking verbs and auxiliaries

¹⁸ Identities cannot be directly perceived, only inferred upon certain perceptions and background knowledge. When an identity is inferred upon visual input, *inok* & siblings are used. When an identity is inferred upon non-visual input, another marker, the SPECIALISED EVALUATIVE MARKER (SEM) is used. Both forms consist of the copula and an element that is derived from the visual or non-visual marker, see also Table 6 and section 3.1.2 below.

¹⁹ The distribution of these two markers differs in the dialects. In the majority of the Shamskat dialects *yin* tends to express a more objective or more generally shared property ascription, whereas *yod* tends to indicate a more subjective and more personal ascription. Other factors, such as temporal or spatial distance, may be involved as well, but to describe all these factors in all dialects goes beyond the scope of this paper.

The counterpart of the MSAP shall here be termed OTHER. These two discourse roles should be understood as flexible vantage points, but not as (grammaticalised) person categories.²⁷ For the notion of a ‘relationship (attitude) of the speaker to the situation expressed’ in contrast to a grammatical person category see also Takeuchi (1990 translated in 2015: 403). Since in the Tibetic languages, the MSAP-related Set 1 markers can only be applied to controllable situations, the category of OTHER includes not only all situations pertaining to 2P and 3P in statements and 1P and 3P in questions, but also all non-controllable and non-controlled situations relating to 1P in statements and 2P in questions.

Socio-pragmatic factors lead to usages that differ from the distribution shown in Table 1. With the exception of the bleached verbs *soñ* and *byuñ* and the marker for non-visual perception *rag*, the auxiliaries and constructions subsumed under OTHER, including the GEM and other evaluative markers, can be used for the MSAP in all temporal domains and *vice versa*, see Table 2.

Such non-prototypical usages are pragmatically conditioned and highly marked (and thus more or less restricted). When using Set 1 markers for OTHER, one claims authority and/ or personal involvement and/ or responsibility for the situation and the OTHER person, except when

²⁰ The alternative form *snay* has been observed as a visual marker in the Ldumrapa dialects, where it occurs besides *hdug*, and as a non-specialised experiential marker in various Baltipa dialects (cf. also Jones 2009; Ebihara 2017: 43–46 for its use in three Baltipa dialects) and in Pangipa.

²¹ The combination of verb stem I plus auxiliary yields a non-continuative present, the combination verb stem I plus CNT (*-en ~ -in*) plus auxiliary yields a continuative present tense form. Non-continuous and continuous imperfect forms are derived by adding the remoteness marker *-pin* to the auxiliary.

²² Only *yod* appears in the neutral, non-continuous present tense and imperfect forms. *yin* appears in some dialects as an alternative to *yod* in the marked continuative constructions. In most dialects so far surveyed, the duration of the situation described would be understood to last somewhat longer when *yod* is used as auxiliary than when *yin* is used. For the question of knowledge types, this distribution does not play any role.

²³ Note that the perfect construction V+LB+*yin* is frequently used for ongoing activities and states, competing thus with the neutral and continuative present tense construction. Based on this continuative function, the combination V+LB+ *inok* & siblings may indicate generic facts, see section 3.4.4.

²⁴ Here again, temporality, e.g. the duration of the situation, and distance may play a role. *yod* tends to indicate a longer lasting result or a situation out of view, *yin* tends to indicate a somewhat shorter result period or a situation in view. On the other hand, *yin* appears when the perfect construction is used for ongoing activities and states. For the question of knowledge types, this distribution does not play any role.

²⁵ While regularly used for personally observed past situations, there are also some neutral applications of the mere stem.

²⁶ In the Shamskat dialects, neither *soñ* nor *byuñ* are used with an experiential value. In the Kenhat dialects, south-east from Leh, along the Indus and in the Gya-Miru side valley, *soñ* appears for events personally observed. In the north-eastern Lalok area and along the Indus from Gyere onwards in the eastern border area, *byuñ* appears for situations directed towards oneself. Unlike in Central Tibetan, however, *byuñ* cannot be used for one’s perceptions and feelings. As several informants confirmed, neither *soñ* nor *byuñ* are fully obligatory. The zero form can still be used for a neutral, detached statement, while the two markers emphasise one’s affectedness.

²⁷ It is somewhat unfortunate that the terminology of ‘conjunct-disjunct’ used in earlier descriptions of the Tibetic system or even the notion of ‘egophoric’ are often understood as person categories. There are, in fact, a few languages in other parts of the world that show a strict grammatical opposition between forms used for the speaker in statements and for the addressee in questions, on the one hand, vs. any other (non-)participant, on the other (note that the two former participant roles may nevertheless receive different markers in some of these languages). See here the recent volume on ‘egophoricity’ by Floyd, Norcliffe, & San Roque (2018). The use of the so-called ‘egophoric’ markers in the Tibetic languages, by contrast, is highly flexible and driven by pragmatic considerations, and any person-related terminology should be reserved for the aforementioned languages.

using the past marker *-pa.yin* for OTHER, which rather indicates that one remembers very well a situation of the distant past. Conversely, when using Set 2 or evaluative markers for the MSAP, one declines authority and/ or personal involvement and/ or responsibility for various reasons, none the least politeness, cf. section 3.3.2, or just in order to talk nicely, cf. section 3.3.3.

If any proof be needed that the Tibetanic ‘evidential’ markers are related to a (first or second) person’s perspective or stance, and do not reflect a person category, this inbuilt flexibility should be evidence enough. Moreover, this flexibility also shows that the system cannot be about different access channels and sources alone.

domain	Set 1:		Set 2 / EM:	
	<i>yin and/ or yod</i>		<i>hdug (~snañ) / zero / GEM / EM</i>	
identificatory copula (LV)	MSAP	OTHER	OTHER	MSAP
future (Aux)	MSAP	OTHER	—	
past/ anterior	MSAP	OTHER	OTHER	MSAP
attributive copula (LV)	MSAP	OTHER	OTHER	MSAP ²⁸
existential, possession (LV)	MSAP	OTHER	OTHER	MSAP
simultaneous (Aux)	MSAP	OTHER	OTHER	MSAP ²⁹
perfect/ resultative (Aux)	MSAP	OTHER	OTHER	MSAP
prospective (Aux)	MSAP	OTHER	OTHER	MSAP
quotation/ hearsay	(MSAP) & OTHER			

Table 2 Prototypical and marked (=shaded cells) use of the linking verbs and auxiliaries

Table 3 gives an overview over the distribution of a subset of evaluative markers across the larger dialect areas. Several of these markers show assimilation features in the onset. This is indicated by a capital non-italic underlined letter. Shading is used for forms with multiple or overlapping functions. As the existential linking verb or auxiliary *yod* cannot combine with the Kenhat element *-ok* or *-ak*,³⁰ nor with the past inferential marker *-tok* or *-Dok/-Duk* of Table 3, the forms *jot-kjak* and *jot-* or *ho-k(an)ak* are used for the Shamskat form *jotsok*, see Table 4.

²⁸ *hdug* regularly appears for the MSAP in contexts of self-perception through various media, including dreams. Logically, as well as psychologically, such mediated self-perceptions are not different from outsider perceptions of OTHER.

²⁹ Apart from self-perception through media, there is also a particular use of *hdug* for the MSAP in the casual polite question (*nerañ*) *fi dzad-duk?* ‘What are you (guys) doing?’, confined to the more central Ladakhi dialects. This casual question is used when one can actually see what the persons are doing or rather when one sees that they are not doing anything, and the most common answer would be *jot le*. ‘[We] are just here, [not doing anything particular].’ Unlike a rhetorical question, this casual question serves as a kind of greeting and may open up a conversation. The GEM or other evaluative markers may be used, at least in some dialects, for activities in which the addressee is likewise involved or with some heightened emotional load, see section 3.4.2, 3.4.6, and 3.4.7.

³⁰ However, in the dialects of the Trangtse area, the element *-dak* does follow the existential, yielding the form *hotak* (*hot-(d)ak*). This can be established, because a dental, when followed by a non-palatal vowel, is weakened to a palatal glide, cf. *hoj-a?* ‘does [it] exist?’, *lajak* ‘Ladakh’, or is even deleted before palatal vowels.

GEM		mirative	inference	distance	past/ narrative
Baltipa	<i>(in-man)</i>		-suk		-(k)hanintsok / - <u>B</u> aintsok
S.Purikpa	<i>(in-tsuk)</i>	—	-suk		- <u>B</u> intsok ³¹
E.Purikpa	<i>intsuk</i>		-suk	-khanintsok	- <u>B</u> intsok ³²
W.Shamma	<i>intsok</i>	- <u>B</u> intsok ³³	-sok		-kha((n)i)ntsok - <u>B</u> intsok ³³
E.Shamma	<i>inok</i>		-sok ³⁴		-kha((n)i)ntsok
S.Shamma	<i>inok</i>		-sok ³⁴	-ka(no)k	(-pintsuk) ³⁵
Central	<i>inok</i>	-suk/-sok	-tok	-kjak	- <u>B</u> intsok ³⁶
Lalokpa	<i>jindak</i>	-suk	- <u>D</u> uk	- <u>G</u> a(na)k, -pak ³⁷	{- <u>B</u> entsok ³⁸ /
Up.Indus	<i>jinak</i>	-suk	- <u>D</u> ok	- <u>G</u> a(na)k	{- <u>G</u> a(i)ntsuk ³⁹
Zanskarpa	<i>hino</i> [?]	-su [?]	- <u>D</u> o [?]	- <u>K</u> a [?]	- <u>K</u> eintsu ⁴⁰

Table 3 Functional distribution of some evaluative markers in the Ladakhi dialect areas

Not represented in Table 3 and Table 4 are the various probability and future inferential markers and constructions. Included in Table 3 are, by contrast, the compound forms of the copula *yin* and the epistemic markers *-ok/-ak/-dak*, and *-suk/-sok*, that is, *inok* & siblings, in order to show that they take the same paradigmatic slot among this particular subset of evaluative markers. These compound forms have developed various meanings of their own that go beyond the sum of the function of the two elements. In particular, these compounds, which are the topic of this paper, are used for generic and mutual or shared and shareable knowledge. I shall treat them as GENERALISED EVALUATIVE MARKER (GEM), that is, markers that have partly lost their more original epistemic function. For their individual shape in various dialects see further below, section 2.5, Table 6 and Table 7.

³¹ Attested for the Sankoopā dialect. According to the informant, the form may be used for becoming aware of past situations and for third-hand knowledge or information handed down through several generations.

³² Attested for the Ciktanpa and Mulbekpa dialects.

³³ Attested for the Tagmacikpa dialect.

³⁴ Only combining with verb stems and the existential linking verb *yod*.

³⁵ As used by a second Lingshetpa speaker. The main informant uses only *-ka(no)k*.

³⁶ Attested for the Rumbakpa dialect.

³⁷ Attested for the dialects of Rale, Traṅtse, Shachukul, Kārgyam, and Merak (Lalok area). The form, which follows only the verb stem, has been described to convey a more certain knowledge than the other distance marker (*-Ganak*).

³⁸ Attested for the Shachukulpa, Çarapa, and Gya-Mirupa dialects.

³⁹ Attested for the Kārgyampa, Gyaikpa, and Gya-Mirupa dialects. Additionally, the Gya-Mirupa dialect has a narrative form NLS-EX-MDST: *-a(ho)tsuk* for the present/ imperfect. Unlike most other speakers, the Gya-Mirupa speaker uses both distance markers also in ordinary speech, when talking about facts that happened before one came to a certain place etc. The *-Gantsuk* form would be used more lightly, the *-Bintsuk* form would indicate greater emotional involvement. In story telling the *-Gantsuk* form appears to be preferred.

⁴⁰ The main function of the form is to indicate inferences upon visual input combined with a strong connotation of unexpectedness, but it is also used in traditional narratives, when seeking the conventionalised confirmation of the audience. It will be replaced by other markers when the speaker gets more involved into the story. According to the Faḍumpa informant, the form is getting obsolete among the younger speakers.

	mirative	inference	distance	past/ narrative
Baltipa		-suk		-khanintsok / -paintsok
S.Purikpa	—	-suk		-pintsuk
E.Purikpa		-suk		-khanintsok / -pintsuk
W.Shamma	no data	-sok		-kha((n)i)ntsok (no data)
E.Shamma		-sok		-kha((n)i)ntsok
S.Shamma	no data	-sok	-ka(no)k	(-pintsuk)
Central	-suk/-sok		-kjak	-pintsuk
Lalokpa	-suk		-ka(na)k, -dak	no data
Up.Indus	-suk		-ka(na)k	-pentsuk/-ka(i)ntsuk
Zanskarpa	-su ²		-ka ²	-keintsu ²

Table 4 Distribution of the evaluative markers of Table 3 with the existential linking verb *yod*

‘evidential’ sentences	‘evidential’ type	meaning
<i>ɲaŋfa(:) bila jot.</i>	Set 1: speaker’s personal sphere	‘We have a cat (intentionally, it’s ours).’
<i>ɲaŋfa(:) pitse duk.</i>	Set 2: visual observation	‘(Apologies:) We have mice (I just saw one/ we see them every day).’
<i>pitse dak.</i>	Set 2: non-visual observation	‘There are mice (I can’t see them in the darkness, but I hear them clearly.)’
evaluative sub-system		
<i>pitse jotsok.</i>	EM: ‘inferential’ marker, inference upon immediate visual input or indistinct hearsay	‘Apparently, there are mice (I just saw some trace or I somehow heard about it).’
<i>pitse jotkhāintsok.</i>	EM: distance marker, reasoning based on less immediate evidence or story telling	‘There must be mice (because of this and because of that).’ / ‘Once upon a time, there were mice’
<i>pitse jotsok lo.</i>	EM & QOM	‘[They] say that there are mice (as they saw traces or heard about it).’
<i>pitse jotfaduk.</i>	EM: GRD & VIS, estimation based on visual input	‘I think there are mice (I see some evidence, but I am not fully sure).’
<i>pitse jotfarak.</i>	EM: GRD & NVIS, estimation based on non-visual input	‘I think there are mice (I hear/ smell something, but I am not fully sure).’
<i>pitse jotay. / jotay lo.</i>	EM: probability marker / & QOM	‘There might be mice.’ / ‘[They] say that there might be mice.’
<i>semfɛn maŋboa skat jote-intsok, spera metpaintsok.</i>	EM: PERF & GEM, shared or shareable (generic) knowledge	‘(As everyone knows,) many animals have voices, [but they] do not have speech.’

Table 5 A selection of existential sentences for Western Shamma

Table 5 illustrates the unmarked or prototypical usages of ‘evidential’ and evaluative markers for existential statements, a person from Western Sham might use about his/her home. The selection

of Table 5 does not show all possible forms, nor all possible meanings. The sentences are formulated only for illustrative purposes. They are based on what I know about the Domkharpa and Tagmacikpa dialects. Instead of *jotkhāintsok*, a speaker from Lingshet would use *jotkanok*. Instead of both *jotsok* and *jotkhāintsok*, a speaker from Leh would use *jotkjak*, and a speaker from the more eastern Kenhat dialects would use *hokanak* ~ *hokandak* or shortly *hokak*.

2.5 ‘Evidentiality’ and the use of *inok* and its dialectal counterparts

2.5.1 Comparability with the so-called ‘factual’ marker *red*

Standard Spoken Tibetan and other Tibetic languages are usually described as displaying additional slots for the copula and auxiliary *red* and for the compound form *yod.red* a.k.a. *yog.red* for the existential counterpart of *red*. In the Amdowa dialects, the existential counterpart takes the form *yod.na.red*, while the copula *red* may have an additional compound doublet *yin.na.red*. These markers would be, according to available descriptions, ‘neutral’ with respect to ‘evidentiality’. If that description is correct, Ladakhi does not seem to have any functional counterpart. However, many instances of such ‘neutral’ use of *red* as a copula could possibly be directly translated by the compound copula and auxiliary *inok* of the Central Ladakhi dialects and its siblings *hinak*, *hindak*, *hinḡak*, and *intsuk* ~ *intsok* elsewhere, different cut-off points notwithstanding. Similarly, the compound form *yod.red* may be translated by the corresponding combination of *yod* with *inok* & siblings. However, apart from a few examples, I shall abstain from an illustration of this claim, because I lack personal experience of the Central and East Tibetan languages, and the available descriptions still leave too much room for interpretation. My claim is primarily based on the assumed ‘neutral’ character of *red* (and its equivalents), with the standard examples given as in (1) and (2).

The examples for Standard Spoken Tibetan are taken from Tournadre & Sangda Dorje (1998: 63, 64, 77, and 191), the Themchen Amdowa examples are from Haller (2004: 69, ex. 47, 70, ex. 48, and 69, ex. 43). The Ladakhi and Pangipa equivalents are constructed, based on my knowledge of the dialects. For more ‘real’ examples, see also section 3.3.1, as well as the subsequent sections for more specific contexts.

When talking about an unrelated person or a not very close person, the choices in Standard Spoken Tibetan, Amdowa, and most Ladakhi dialects are practically congruent, with *red* being used in the two former languages and *inok* & siblings in the latter dialects.

- (1) a. Introduction of an unrelated (and absent) person
- | | | | | | | | |
|---------------|------------|----------------|---|-------------|---------------|-----------------|-------------------------|
| <i>khōŋ</i> | <i>sū</i> | <i>reʔʔ</i> | – | <i>khōŋ</i> | <i>lōsaŋ</i> | <i>reʔ</i> . | Standard Spoken Tibetan |
| <i>kharge</i> | <i>shə</i> | <i>reʔ</i> | | | | | Themchen Amdowa |
| <i>kho</i> | <i>su</i> | <i>intsokʔ</i> | – | <i>kho</i> | <i>lobzaŋ</i> | <i>intsok</i> . | Western Shamma |
| <i>kho</i> | <i>su</i> | <i>hindakʔ</i> | – | <i>kho</i> | <i>lōbzaŋ</i> | <i>hindak</i> . | Lalokpa |
| he | who | be | | he | [name] | be | |
- ‘Who is he? – He is Losang ~ Lobzang.’

b. Negated professional identity of an unrelated (and absent) person

<i>khōŋ</i>	<i>kēken</i>		<i>mqreʔ</i> .	Standard Spoken Tibetan
<i>kharge</i>		<i>caŋwa-zəç</i>	<i>mare</i> .	Themchen Amdowa
<i>kho</i>	<i>gergan</i>		<i>mentsok</i> .	Western Sham
<i>kho</i>	<i>gergan</i>		<i>mandak</i> .	Lalokpa
<i>kho</i>	<i>gegen</i>		<i>menne</i> .	Pangipa
he	teacher / farmer-LQ		NG.be	
'He is not a teacher / a farmer (<i>caŋwa-zəç</i>).'				

If the person is closely related, speakers of Standard Spoken Tibetan may use *red* besides *yin*, most likely for socio-pragmatic reasons. Ladakhi speakers, on the other hand, would use only the copula for the identification of a person in view. In this context, ego-centred knowledge or the right to exclusive personal knowledge overrides other pragmatic factors.

(2) Identification or introduction of a closely related person

<i>khōŋ</i>	<i>sū</i>	<i>reʔʔ</i>	–	<i>ŋɛ:</i>	<i>pālaʔ</i>	<i>reʔ</i> .	Standard Spoken Tibetan
	<i>t̪i</i>			<i>ŋɛ:</i>	<i>t̪awo</i>	<i>j̪in</i> .	Standard Spoken Tibetan
	<i>ndə</i>			<i>ŋə</i>	<i>topma</i>	<i>j̪ən</i> .	Themchen Amdowa
<i>kho</i>				<i>ŋi</i>	<i>abale</i>	<i>in</i> / <i>*intsok</i> .	Western Shamma
<i>kho</i>				<i>ŋɛ</i>	<i>abale</i>	<i>hin</i> / <i>*hindak</i> .	Lalokpa
s/he	who	be	–	my	father.hon /	be	
	this				wife / student		

'Who is he? – He is my father.' / 'This is my wife (*t̪awo*) / my student (*topma*).'

In Standard Spoken Tibetan, there are apparently two options for persons closely related: *j̪in* and *reʔ*. It is nowhere stated whether these options depend on formal factors, such as the form of the question, or on socio-pragmatic factors, such as the status of the person talked about in relation to the speaker and/ or addressee. However, the latter factor seems to play an important role. In the first case (Tournadre & Sangda Dorje 1998: 77), the speaker, using *red*, talks about her father whose status is higher, with respect to both the speaker and the addressee, which is also indicated by the honorific marker *khoŋ* and the honorific suffix *-laʔ*. In the second case (Tournadre & Sangda Dorje 1998: 191), the speaker, who, by virtue of his age, would be higher in status than the addressee, refers with *yin* to his wife, who, alas!, traditionally has a lower status, equally indicated by the lack of the honorific marker and by a demonstrative pronoun instead of a (honorific) personal pronoun. In another dialogue (Tournadre & Sangda Dorje (1998: 197), the speaker, this time being equal to the addressee, introduces his wife with *reʔ*, while using *j̪in* and the demonstrative pronoun for his little daughter, although the question about the child was formulated with *reʔ*. The form of the question thus seems to be irrelevant. With the use of *reʔ*, the speaker apparently downplays his or her epistemic authority vis-à-vis a respected person, while the use of *j̪in* may, by contrast, signal that there is no need for such a distanced polite or respectful attitude.

Rev2 objects that the use of *reʔ* would not be a sign of polite downgrading, but would simply represent or 'assert' the situation as a 'fact'. The use of *j̪in*, by contrast, either would be quite emphatic or would indicate that the speaker is quite possessive (cf. also Agha 1993: 176 for the notion of a "possessor perspective" or a pragmatic foregrounding of the relationship between the speaker and his/her daughter). The specific notion of 'emphatic' remains unspecified by Rev2. Whatever its exact function, the copula *j̪in* is certainly referring to, or asserting, a fact and not a hypothesis or a dream or a wish. Given the use of the non-honorific forms in combination with

jīn, I think one can rule out an emphatic or engaged usage of *jīn* that might indicate one's greater attachment to the person in question. A possessive stance, however, fits well with the use of the non-honorific forms. The elderly man treats his wife as his possession and so does the younger man with respect to his child. By contrast, the first speaker talks about her father in a less possessive, less attached, or, if one wants so, more neutral manner, and so does the younger man with respect to his wife. I would think that this more detached or less possessive way of speaking is certainly more respectful than the possessive stance. Whatever the notion of 'factual' is supposed to mean (if it does mean anything, at all), one should always look for the motivation behind using a more 'factual' or 'neutral' expression in contrast to a less 'neutral' or more engaged/ affective expression.

Whether the factor of status or possessive vs. non-possessive stance may play a role also in the Themchenpa example is impossible to say, for lack of counter examples. In any case, different cut-off points or different effects of socio-pragmatic factors would not affect the claimed 'factual' status of *red* in the Amdowa dialects. Similarly, they should not affect the status of *inok* & siblings as a functional counterpart of *red*.

The fact that *inok* & siblings may translate many instances of *red* does not automatically imply that *red* could translate as many instances of *inok* & siblings. As will be shown below, *inok* & siblings have various epistemic and pragmatic functions that may or may not be covered by *red*. Unfortunately, such contexts are as yet hardly discussed in the literature. Part of the motivation for writing this study is to allow other researchers to look for similar usages of *red* or its equivalent in other Tibetic languages or even beyond. I shall provide parallel examples from other Tibetic languages, wherever I came across one. Even though these are only isolated examples, they might show that several of the functions of *inok* & siblings that do not correspond to an analysis as 'factual' (whatever that actually means) might also be attested for the so-called 'factual' markers more widely in other Tibetic languages. They may thus also show the close functional relationship between *inok* & siblings and these 'factual' markers and may thus further also demonstrate the need to develop a better analysis for the latter. With respect to *inok* & siblings, I intend to show that even though in some of their usages "it does not matter whether one has seen it [i.e., a situation] or not" as one informant put it, *inok* & siblings do not present situations neutrally.

2.5.2 *The various forms of inok & siblings*

In all Ladakhi dialects, *inok* & siblings are composed of the copula and an element that is related to the experiential or visual marker *hdug*, but also reflects a more original admirative (or non-confirmative)⁴¹ expression of non-commitment of *hdug*. This non-committed stance has led to an inferential value or an epistemic value of probability in various derivations of *hdug* (see Zeisler 2017a for these seemingly contradictory developments).

Table 6 lists the various forms of *inok* & siblings I came across. They are listed here together with a related counterpart for inferences and identifications, based on non-visual input, but no particular pragmatic values, listed as SEM (for SPECIAL EVALUATIVE MARKER). This is likewise a compound form with the copula as first element. It will play a role only in section 3.1.2, examples (27) to (30); its non-use plays a marginal role in section 3.3.4. The counterparts of the Pangipa,

⁴¹ See Friedman (1981, 2000) for this value. The term 'admirative', as established for various Balkan languages and as used here, should not be confounded with the much narrower term 'mirative'. See Zeisler (2017b/2018a) for a detailed discussion of these terms and their applicability or non-applicability with respect to the Tibetic languages.

Baltipa, and southern Purikpa dialects, which show a much less developed non-epistemic functionality, are given in brackets. Table 7 summarises the negated forms.

dialect	dialect region	GEM	SEM	non-visual
Turtuk area	Eastern Balti	(<i>inmaj</i> ⁴² / <i>intsuk</i>)	—	—
Sankoopā	Southern Purik	(<i>intsuk</i>)	—	—
Kargilopā	Western Purik	(<i>insuk</i>)	—	—
Mulbekpā, Ciktanpā	Eastern Purik	<i>intsuk</i>	<i>inɖak</i>	<i>ɖak</i>
Sumurpā	Central Ldumra	<i>intsuk</i> ⁴³	<i>inak</i>	<i>rak, -ak</i>
Tagmacikpā	Western Sham	<i>intsok</i>	<i>inɖak ~ inak</i>	<i>ɖak, -nak</i>
Domkharpā	Western Sham	<i>intsok</i>	<i>inak</i>	<i>ɖak, -nak</i>
Teyapā	Eastern Sham	<i>inok</i>	<i>inak</i>	<i>ɖak, rak, -nak</i>
Saspolapā	Eastern Sham	<i>inok</i>	[<i>inak</i>]	<i>rak, -nak</i>
Lingshetpā	Southern Sham	<i>inok</i>	<i>inak</i>	<i>dak (!), rak, -(n)ak,</i>
Rumbakpā, Lehpā	Central Ladakh	<i>inok</i>	<i>inɖak</i>	<i>rak</i>
Lehpā, 2. generation < Upper Indus ⁴⁴		<i>inok</i>	<i>indarak ~ inɖak</i>	<i>rak</i>
Ralepā				
Shachukulpā, Kārgyampā	Lalok	<i>hindak</i>	<i>hinrak</i>	<i>rak</i>
Merakpā	Lalok	<i>jindak ~ jīnak</i>	<i>jindarak ~ jīnrak</i>	<i>rak, ɖak</i>
Liktsepā	Upper-Indus	<i>jīnak</i>	<i>jīnɖak</i>	<i>rak</i>
Çarapā, Gyaikpā, Kyungyampā	Upper-Indus	<i>jīnak</i>	<i>jīndarak</i>	<i>rak</i>
Gyerepā	Upper Indus	<i>jīndak</i>	<i>jīnrak</i>	<i>rak</i>
Gya-Mīrupā	Upper-Indus	<i>hinak</i>	<i>hindarak</i>	<i>rak</i>
Kuyulpā	Tibetan border	<i>hindak</i>	<i>hinɖak</i>	<i>ɖak</i>
Mūtā	Tibetan border	<i>jīndak</i>	<i>jīnɖak</i>	<i>ɖak</i>
Kharnakpā	Himachal border	<i>jīnɖa</i> ² (!)	<i>jīnɖa</i> ²	<i>ɖa</i> ²
Faɖumpā	Zanskar	<i>hino</i> ²	<i>hinɖa</i> ²	<i>ra</i> ²
Paldarpa ⁴⁵	Zanskar enclave	<i>hino</i> ²	<i>hinderā</i> ²	<i>ra</i> ²
Pangipa ⁴⁶	mixed enclave	(<i>jīnne</i>) ⁴⁷	—	—
Spitipā	Himachal, India	<i>jīnuk</i>	(<i>jīndarak</i>) ⁴⁸	<i>ɖak, rak</i>
Lendepā	Kyirong, Tibet	<i>jīmbe</i> . ⁴⁹	—	—
	S. Mustang, Nepal	<i>rak ~ nak</i> ⁵⁰	—	—

Table 6 GEM, SEM, and the marker for non-visual sense perception

⁴² Bielmeier (1985: 177) notes a form *inanj* for the Khapulu dialect, which he analyses as “intensiviertes Präsens” (intensified present), with the negated form *menanj* (p. 195), analysed as ‘affirmative’. Both forms appear only once in the story (8,12; 8,13) and concern a prediction. That would at least correspond to the irrealis function, discussed in sections 3.1.5 and 3.2.

GEM	SEM	non-visual
<i>intsuk – mentsuk</i>	<i>inḍak – menḍak ~ manḍak</i>	<i>ḍrak – minḍak ~ minak</i>
<i>inok – menok ~ manok</i>	<i>inak – menak ~ manak</i>	} <i>rak – mirak ~ minak ~ merak ~ meak</i>
<i>hindak – mandak</i>	<i>hinrak – manrak</i>	
<i>hinak – manak ~ mak</i>	<i>hindarak – mandarak</i>	
<i>ino[?] – ma[?]</i>	<i>inḍa[?] – manḍa[?]</i>	<i>ra[?] – mera[?]</i>
<i>jḥnḍa[?] – manḍa[?] ~ ma[?]</i>	<i>jḥnṭa[?] – [manṭa[?]]</i>	<i>ṭa[?] – meṭa[?]</i>
<i>inmaṅ – menmaṅ</i>		cf. visual
<i>jinne – menne</i>		<i>duk – minduk ~ mindu[?] ~ minuk ~ miruk ~ miuk</i>

Table 7 The negated forms of the GEM, SEM and non-visual marker (summarised)

In Pangipa, the past experiential marker *ne* (of unknown origin) follows the copula. In the dialects of the Turtuk area, the copula is followed by a nominaliser *ma* and the element *-aṅ* (< *snaṅ* ‘appear’). The latter element functions as an experiential marker in Pangipa, Turtukpa, and some other Baltipa dialects, and as a visual marker in various Ldumra dialects, besides being used as a probability marker in various Shamskat and Kenhat dialects. A shortened form of *ḥdug*: *-ok* or *-ak*

⁴³ The marker takes the form *inzuk* in the more northern dialects of Henache and Aranu.

⁴⁴ The speaker has grown up in Leh, her parents, however, come from the Upper Indus region. The speaker is thus a Lehpa only in second generation and a speaker of the Lehpa dialect as L1 only in first generation. Infrequently she still shows features of her heritage dialect, as, e.g., shown in her variation in the form of the SEM.

⁴⁵ Paldar is an enclave in the Kishtwar district of Jammu & Kashmir. The dialect is clearly of the Zanskarpa type.

⁴⁶ Pangī is a district (*tehsil*) in Himachal Pradesh. The language, spoken in a few hamlets in the upper part of the valley is a strange mixture of Baltipa and Zanskarpa features, plus features of an – as yet – unidentified Tibetic language. Strangely enough, Pangī is sandwiched between Paldar and Zanskar, which do not show these particularities.

⁴⁷ The element */ne/* is also found as a past tense form for the Set 2 marker *snaṅ*. It thus compares to *yod.sug* in Purikpa, which replaces the Set 2 marker *ḥdug* in past time reference.

⁴⁸ Hein (2001: 198, 2017: 117) mentions the form as part of an inferential construction, without, however, describing its function in detail.

⁴⁹ Huber (2005: 99, 101, 130) describes the form as indicating both immediate sense perception and inference.

⁵⁰ Kretschmar (1995: 108; cf. Biemeier 2000: 113–121). The verb functions as a copula, not as an existential verb. According to Biemeier (p. 113 with n. 28), the marker *raḱ ~ naḱ* would correspond to Lehpa *inok*. Formally, however, correspond to Central Tibetan *red*, the spelling of which Biemeier takes to be “unjustified” (Biemeier 2000: 121, n. 32). It is apparently commonly used for self-identification or talking about own things (cf. Kretschmar 1995: 109; Biemeier 2000: 116, 118f.). Kretschmar (1995: 108) describes it as more neutral, the use of *jḥn* (*vin*) as more emphatic. *raḱ ~ naḱ* also combines with the existential \emptyset (< *yod*) and the elements *ta* and *ka* (both of unknown origin), yielding *ṭarak* (~*ṭanak*) and *ḱarak* (~*ḱanak*). According to Kretschmar (1995: 108), *ṭarak* would indicate personally attested knowledge similar to *ḥdug*, while *ḱarak* would express one’s personal conviction. One may wonder, however, whether the alternative form *ḱanak* would not correspond to the Kenhat existential combination *ḥoka(na)ḱ* (*yod* plus distance marker), which is used for somewhat more indirect or less certain knowledge.

follows the copula in the Kenhat dialects. In the Lalokpa dialects, this element is either less reduced or supplied with an additional *-d-* element: *-dak*.⁵¹

In the Purikpa and Western Shamma dialects, the copula is followed by the inferential-*cum*-distance marker *-suk/-sok*, which results from a perfect construction containing again the experiential marker (V-*ste*+*hdug*).⁵² This compound form is also attested in the dialects of the Turtuk area, where it mainly indicates a past realisation or the delayed realisation of a past situation, commonly also hearsay. Infrequently, it is also found with generalised, i.e., non-epistemic functions.

The short element *-ok/-ak* that is found in the Kenhat dialects also appears in various dialects after the verb stem as a future inferential marker. Both short forms are further found after the nominalising (?) element *ka* of unknown origin plus a nasal residue of the copula *yin* for the Southern Shamma and Kenhat distance markers: Lehpa *-kj-ak* (<*-ka.yin.hdug*), Lingshetpa *-kan-ok*, Faḍumpa *-kan-o*?, other Kenhat dialects *-kan-ak*, or *-kan-dak* (<*-ka.yin.hdug*), all, except the Lehpa form, often shortened to *-kak* (in negation, the marker follows the negated verb stem: *ma-V-kanok*, *-kan(d)ak/-kak*). Some Kenhat dialects have a formally similar future inferential *-kan-ak/ -kak* (negated V-*kamanak/ -kamak*). This functionality points to an epistemic and or admirative origin of the element *-ok/-ak*, and explains the epistemic functions of the compound form with the copula. For the development of the Baltipa and Kenhat markers derived from *snay* and *hdug* as, on the one hand, markers of immediate sense perception and, on the other, as probability or inferential markers, see Zeisler (2017a). The apparent incompatibility vanishes if one accepts that both functions developed out of an originally admirative or non-confirmative value of the markers and that the differences between (limited) direct observation, inference, and guessing are only gradual.

Unlike other combinations, the combination of the copula *yin* and this second epistemic element *-ok/-ak/-dak*, or *-suk/-sok* (and in part also *-ay* and *-ne*) has developed new functions of its own, that is, the whole is more than the sum of its parts, which is why I treat the compound as a whole. I have chosen the term GENERALISED EVALUATIVE MARKER (short GEM) to point to its multifunctionality as an epistemic marker, on the one hand, and a generalised, that is, epistemically neutralised, marker for shared and shareable knowledge and other conventionalised pragmatic usages, on the other. As the epistemic function of the second element has bleached out in many contexts, the compound form no longer has a definable inherent or intrinsic meaning. The exact meaning of a particular GEM copula or auxiliary entirely depends on the specific context. Since Rev1 accuses me of mistaking contextual for inherent connotations, I should like to make it clear that nowhere shall I ascribe a single inherent meaning to the GEM; this simply can no longer be defined. I am not the first one to describe multiple functions. With respect to the copula *re*: in the dialect of Dege, Häsler (2001: 11) mentions the more abstract categories of non-volitionality and new knowledge, which had been discussed for the ‘evidential’ or ‘egophoric’ systems so far, adding the possibility of its use for just being polite by making a more general statement. She further comments that it “is the situation and the context of the utterance that determines which of these different interpretations conveys the *intended meaning*” (emphasis added).

⁵¹ I should hold that the *a* vowel of these forms simply results from de-accentuation. Tournadre and Suzuki (2023: 331, 340), however, maintain that these forms originate from the verb (*hdag*) ‘be correct’ or rather ‘clean, clear, wash off’. It remains unclear how the semantics of this verb could be exploited for its use as a counterpart of *hdug*.

⁵² Cf. also Zemp (2017). Note that in Western Shamma, the marker regularly appears with epenthetic *-t* after final *-n*, frequently also after final *-l* and *-r*, hence *-tsuk/-tsok*. This has led to some misunderstandings concerning its etymology (see Zeisler 2017a: 275–277).

2.5.3 *The existential counterpart*

Table 1 above indicates an important asymmetry between identificatory and existential functions. While the existential function comes with special markers for knowledge based on sense perception, no such marker exists for the identificatory function. This is a common feature throughout the Modern Tibetic languages, see, e.g., Suzuki & al. (2021: 77–80) for two dialects of Kham. The reason for this lack is that identities cannot be perceived but only inferred, if not already known. As a consequence of this asymmetry, there is also no exact counterpart for *inok* & siblings on the existential side in the relevant functional slots. However, combinations of *yod* and *inok* & siblings, like the combination of *yod* and *red*, may fill the gap, at least partially, cf. Table 8. Similar combinations of *yod* with the ‘factual’ or ‘neutral’ copula may be found in many, if not most, Tibetic languages, cf. examples (3) for Standard Spoken Tibetan and (4) for the Amdowa dialect of Gcig.sgril. In the Denjongke language of Sikkim, *yod* is combined with the ‘neutral’ copula *bε?* (written as *sbad*), yielding *jèbbe?* (~ *jòbbe?*) < *yod.pa.sbad* (Yliniemi 2019: 257, Table 7.1, 281, Table 7.2), example (5).

Language/ dialect group	existential combinations
Standard Spoken Tibetan	<i>jɔː-reʔ</i>
Gcig.sgril Amdowa	<i>jo-nəret</i>
Denjongke (Sikkim)	<i>jè·bbe?</i>
Eastern Baltipa	<i>jot-pan(maŋ)</i>
Eastern Purikpa, Western Shamma	<i>jot-e-intsuk / -intsok</i>
Southern Shamma, Central Ladakhi	<i>jot-e-inok</i>
Upper Indus and Lalokpa	<i>hot-e-in(d)ak</i>
Pangipa	<i>jɔː-jinne</i>

Table 8 An existential counterpart for the ‘factual’ or ‘neutral’ copula and the GEM

- (3) Standard Spoken Tibetan (DeLancey 2018: 582, ex. 3, adapted)
pøʔ-la jāʔ jɔː-reʔ.
 Tibet-ALL yak exist.FACTUAL
 ‘There are yaks in Tibet.’ (**General knowledge**)
- (4) Dialect of Gcig.sgril (Amdo; Tribur 2019: 294, ex. 284, slightly adapted)
mɲi za-ŋkhan-gə ɕtak jonəret.
 person eat-NLS-ERG tiger exist.FACTUAL
 ‘There are man-eating tigers.’ Or: ‘Man-eating tigers exist.’ [**Generic knowledge**]
- (5) Denjongke, Sikkim (Yliniemi 2019: 286, glossing adapted)
óna gjømpo_tci? jèbbe?
 there monastery_INDEFINITE⁵³ exist.NEUTRAL
 ‘There’s a monastery there.’ (“The copula *jèbbe?* here marks **generally known, uncontested knowledge.**”)

⁵³ Yliniemi (2019) uses the equal sign for clitics. This is here represented with the underscore.

Except for Pangipa and the Baltipa dialects of the Turtuk area, the Ladakhi existential combinations with the GEM are based on a perfect construction: *yod*-LB-GEM, cf. examples (7) to (9), further examples (182) and (183) on p. 105, and the second alternative of example (213) on p. 119. In the Pangipa dialect, the existential is combined directly with the GEM, example (10). In the Turtukpa dialect, a completely different construction is found: *jotpan* (< *yod.pa.yin*) when talking about a situation close by and *jotpanmaŋ* (< *yod.pa.yin.ma.snaŋ*) when talking about a distant, invisible, or imagined situation, example (6).

Like *yod.red*, the Ladakhi constructions may be used for less immediate knowledge as well as for generic knowledge. In the latter case, the Ladakhi dialects differ somewhat in whether the addressee is expected to know (Shamskat) or expected not to know (Kenhat). In the following, I shall give only examples for generic knowledge. For the Purikpa dialect of Ciktan, cf. also example (182) in section 3.4.3.

- (6) a. Turtukpa (Eastern Baltipa, field data 2017)
turtug-aŋ purana miŋbin majid-po jot-pa+n-m-aŋ. / jot-pa+n.
 Turtuk-PPOS old reputation mosque-DF have-NLS+CP-NLS-EXP have-NLS+CP
 ‘In Turtuk, there is the old famous mosque.’ (The speaker explains the **generally known fact** while being in Leh / while being in or near Turtuk.)
- b. Turtukpa (Eastern Baltipa, field data 2017)
byoltshoŋ-la pera (!)⁵⁴ met-pa+n.
 domestic.animal-AES speech NG.have-NLS+CP
 ‘Animals don’t have speech.’ (**Generic knowledge**, and/ or explanation.)
- (7) Tagmacikpa (Shamskat, Western Shamma, field data 2019)
ɟamupa+(:) rta met-pa-intsok; balan jot-e-intsok.
 Jammu.person+AES horse NG.have-NLS-GEM=PERF⁵⁵ cow have-LB-GEM=PERF
 ‘The people of Jammu do not have horses (**as is generally known**); [they] have cows (**as is generally known**).’
- (8) Teyapa (Shamskat, Eastern Shamma, field data 2018)
turtug-i phaŋiŋ zimbo inok. / jot-e-inok.
 Turtuk-GEN dried.apricot tasty be=GEM be(X)-LB-GEM=PERF
 ‘The dried apricots of Turtuk are tasty (as you might not know / **as everybody including you would know**).’
- (9) Shachukulpa (Kenhat, Lalokpa, field data 2016)
ŋa thorim-lopt+enaŋa urdu sil-pin.
 I high(est)-school+PPOS Urdu study-RM=ASS.PA
urd+inaŋa galip ma: faeri [read: faer] ma: miŋŋan-ŋfik hiindak.
 Urdu+PPOS Ghalib very poet(ry) very famous-LQ be=GEM
khō-e haweli dilli-a ɟama madzid-iŋēōa fiot-e-indak.
 hon.s/he-GEN villa Delhi-ALL Jāma masjid-PPOS exist-LB-GEM=PERF

⁵⁴ One could have expected the Baltipa pronunciation *xpera* or at least *spera*, as used by the Tyaksipa speaker.

⁵⁵ Like in other Tibetic languages, the Ladakhi tense forms are quite complex so that the resulting function cannot be guessed from the combination of morphemes in question. Furthermore, some constructions differ considerably in negation. For this reason, the actual function is specified with the equal sign, which means just what it is: ‘equals’.

tə haweli+(:)nāa galib-e kū-zik hot-e-indak.
 that villa+PPOS Ghalib-GEN statue-LQ exist-LB-GEM=PERF
khō-e tīṅḍjug-e nākfa hot-e-indak.
 hon.s/he-GEN last-GEN photograph exist-LB-GEM=PERF

‘I studied Urdu [literature] at the university. Ghalib is very famous among the Urdu poets. (As generally known,) his villa **is** near the Jāma masjid in Delhi. In that villa, there **is** a statue of Ghalib [and] there **is** a photograph of him in his last days.’ (Suggestion for a talk in a seminar; the audience is not expected to know.)

The form *hoteindak* thus indicates **shareable knowledge**. The speaker further does not claim authority, as Ghalib is not a Ladakhi. The speaker, however, claims certain knowledge based on her studies. The part about the *haweli* is based on my request for translation and my claim of certain knowledge through academic instruction and a personal visit of the *haweli*. – Such visit would trigger the visual marker, when talking only of one’s personal experiences among one’s family or one’s friends. In an official talk, however, a non-personal rendering is preferable, if not obligatory.

(10) Pangipa (mixed variety, Himachal enclave, field data 2017)

alea-saṅ jarte soṅ-ne, ton jə-jinne.
 Alea-CNTR upward go.PA-CD Ton exist-GEM
thorte joṅ-ne khōl jə-jine.
 downward come-CD Khōl exist-GEM

‘If you go up from Alea, there **is/ will be** Ton. If you go down, there **is/ will be** Khōl.’ (General knowledge: the speaker describes the area around her village.)⁵⁶

Formally, the combination of the existential with the GEM takes the same slot as the combination of *yod.red* in Central Tibetan, *yod.na.red* in Eastern Tibetan, or *yod.pa.sbad* in Southern Tibetan. This again may indicate the close formal and functional relationship between *red* and the GEM across the dialects. There are, of course, also important functional differences between *yod.red* (or any equivalent) and the combinations of *yod* and *inok* & siblings: the Shamskat Ladakhi combinations tend to be restricted to generic contexts and often indicate that one expects the addressee to know, as well. The Kenhat Ladakhi combinations are more common for inferences, but when used for generic knowledge, it is assumed that the addressee does not know. In both dialect groups, the combinations also appear to be more emphatic, and tend to be avoided in neutral contexts.

2.5.4 Overview of the functions of *inok* & siblings

In the following, I shall focus mainly on the GEM as a copula and as an auxiliary. Despite the difference in form and a somewhat broader functionality of the second element, the compound form *intsok* of the dialects of Western Sham and *intsuk* (or *inzuk*) of the Ldumrapa dialects takes practically the same slot in the system as *inok* and its merely phonetic variants. The functions of *intsok* and *intsuk* (or *inzuk*) correspond almost exactly to those of *inok*, and the observable differences are in a range that can be found also in the application of *inok* and its other forms between the respective dialects or just between individual speakers of one dialect.

⁵⁶ Like in various other Kenhat dialects, it is possible in the Pangipa dialect to describe the location of villages and hamlets in relation to each other alternatively with the GEM. In some dialects, even the plain copula may be used. The reason for such copula constructions for existential relations could not yet be established.

In the eastern Purikpa dialects of Mulbek and Ciktan, the functional parallelism appears to be restricted mainly to the use of *intsuk* as a copula. In its auxiliary function, the inferential value is dominant. I shall thus apply the label GEM only to these copula functions. Similarly, generalised, non-inferential, or non-admirative values of Turtukpa *inmaj* or *intsuk* and Pangipa *jinnε* are so far observed only in their function as a copula.

The Eastern Purikpa dialects further differ with respect to the pragmatic conditions and hence also with respect to the frequency of the GEM. The southern Purikpa dialect of Sankoo has even less of such generalised usages than the eastern Purikpa dialects, and the same appears to be true for the dialect of Kargilo, described by Zemp (2018). But while there may be less contexts where speakers of the Purikpa dialects feel the need to use the compound form *in(t)suk* in a non-epistemic function, the contexts where they do so, even without feeling an obligation to do so, correspond to contexts where the GEM is used in other dialects, and in all such contexts, the particular function or meaning of *in(t)suk* and the GEM elsewhere is practically the same.

I cannot say anything about the frequencies in the overall use of the GEM and the frequencies of the use for the different functions described below, because this would presuppose the existence of large corpora of comparable content for all dialects, something that is beyond my possibilities. What I can do, and what I have done, is looking for the various contexts in which *inok* & siblings occur, and test and discuss these contexts with as many speakers from as many dialects as possible. While the data is certainly not complete, because new contexts and new interpretations continue to come into light with every new speaker, I am convinced that the data represented here is robust enough for most of the contexts and functions described below. When the data are still insufficient, this will be noted.

I shall start with functions that result from the synchronically most prominent epistemic values of the second element of the form, namely the inferential value of *-ok/- (d)ak* and the somewhat broader value of non-commitment of *-suk/-sok*. The more generalised functions will be discussed towards the end. As far as possible, the functions of the GEM as a copula will be discussed before its functions as an auxiliary in perfect and prospective constructions.

In accordance with the original admirative (i.e., non-confirmative) function of the second element, *inok* & siblings are commonly used for inferences, examples (11) to (22) in section 3.1.1. They are further used when identifying an object or a person through immediate perception of any kind in the dialects of the Balti-Purikpa group and in Pangipa, or, in all other dialects, through vision or immediate perception, contrasting then with a different marker, the already mentioned SPECIAL EVALUATIVE MARKER (SEM), when the identification is through less immediate perceptions, examples (23) to (37) in section 3.1.2. A slightly different usage has been observed in the Faɖumpa dialect, example (38). Related examples with the ‘factual’ or ‘neutral’ marker have been attested in the Amdowa dialect of Mabzhi, the Khampa dialect of Choswateng, and in Standard Spoken Tibetan, examples (39) to (41). Identifications on the base of sense perceptions necessarily imply inferences, as identities can neither be seen nor heard or even tasted or smelled. Related to this is the use of the GEM for sudden realisations of unexpected facts, examples (42) to (51) in section 3.1.3, where the GEM or especially the mirative distance marker *-suk/-sok* may be the only choice, even for the Kenhat dialects. A related example with the ‘factual’ or ‘neutral’ marker has been found in the dialect of Lende, Kyirong, example (52). Similarly, either the GEM or the mirative distance marker are used when in narratives the identity of a personage is unveiled, examples (53) to (60) in section 3.1.4. In most cases, this usage may be interpreted as conventionalised background information. The use

of *insuk* in a historical text from Shigar in Baltistan points into this direction, example (61). However, examples from the Sankoopā dialect of Western Purik and the Tyaksipa dialect of the Turtuk area indicate that the origin of this convention was an epistemic stance of sudden realisation, *shifted* to the narrated person, examples (62) and (63). *inok* & siblings are further used for assumptions in prospective constructions, examples (64) to (69) in section 3.1.5.

The connotation of non-commitment or non-confirmativity that goes along with knowledge ‘merely’ inferred or just realised is also applicable to an irrealis mode, which shows up infrequently in conditional assumptions about the future, examples (70) and (71) in section 3.2.1. More regularly, the GEM is used in stage directions and particularly in children’s assignments of play roles. The element *-suk* may again appear in the Kenhat dialects, besides the ordinary distance markers, examples (72) to (75) in section 3.2.2. In the case of the Western Shamma dialects, the irrealis function of the inferential-*cum*-distance marker *-suk/-sok* has merged with the generalised functions in the compound form *intsok* and can no longer be separated. Similar examples with the ‘factual’ or ‘neutral’ marker are found in Standard Spoken Tibetan and the dialect of Mabzhi in Amdo, examples (76) and (77). The GEM is further used in imagined situations for explanations, examples (78) to (84) in section 3.2.3. Here again, similar examples with the ‘factual’ or ‘neutral’ marker have been found both in Standard Spoken Tibetan and Denjongke of Sikkim, examples (85) to (88).

The imaginative function of prospective constructions combined with *inok* & siblings is exploited for explanations, planning, and suggestions, and serves to avoid stricter expressions of necessity or even commands, examples (89) to (105) in section 3.2.4 and (214) in section 3.4.4. This latter usage for planning and suggestions, where the construction has lost most if not all of its epistemic values, may also be analysed as a conventionalised strategy of modesty or politeness in the communicative interaction. This holds also for all other applications of *inok* & siblings to be described subsequently.

In these latter applications, *inok* & siblings, far from being neutral, express a speaker’s attitude towards both the content and towards the addressee (in questions, of course, they express the expected attitude of the addressee towards the speaker). This attitude varies according to the context and the socio-pragmatic constraints. The opposition between the plain copula and *inok* & siblings serves among other things to express one’s mental, spatial, or temporal closeness or distance to persons or other items identified or introduced. In a neutral context, the use of *inok* & sibling’s indicates the speaker’s reduced subjective acquaintance and/ or his/her emotionally coloured relationship, see section 3.3.1 with examples (106) to (113). In a marked context of explanations, the speaker will focus more on the knowledge state and interest of the addressee, see sections 3.4.3 to 3.4.5.

How important this focus on the addressee is in the social interplay will be shown in section 3.3.2 with examples (114) and (115). If one does not use the GEM in certain communicative contexts, this may be taken by the addressee as an aggression or insult. By contrast, the use of *inok* & siblings in gentle speech to children is rather playful, section 3.3.3, examples (116) to (124). This usage has been attested even in the peripheral dialects of Turtuk, (116), and Pangī, (124), but the use of a the ‘factual’ or ‘neutral’ marker seems also common among other Tibetic languages, as the example from the dialect of Gcig.sgril in Amdo, example (125) shows. Temporal and spatial distance plays a role that becomes evident when asking and reporting about absent persons, and the addressee’s interest to know overrules the speaker’s access to knowledge, examples (126) to (136), in section 3.3.4. The focus on the addressee’s supposed knowledge is particularly evident in the collocation ‘you bought it yourself’ to express the notion of ‘don’t blame others, it’s your own fault’ associated with either reprehension or *schadenfreude*, examples (137) and (138) in section 3.3.5. A similar

shift is shown in the special treatment of the addressee's non-ownership as falling out of the speaker's territory of information, even when the speaker can call the item in question his/her own, example (139) in section 3.3.6.

In some regions, speakers may downgrade their speech when they are feeling shy or weak, examples (140) to (144) in section 3.3.7, and this may also be exploited for sarcastic speech, examples (147) to (149) in section 3.3.8. A comparable usage with the 'factual' or 'neutral' marker has been observed in Lhasa Tibetan, example (150). Examples (151) and (152) in section 3.3.9 will point to other potential usages for emotionally loaded assertions concerning the speaker. Comparable examples have been described for Standard Spoken Tibetan, examples (154) and (155).

Some speakers may use *inok* & siblings to avoid the visual marker (implying personal observation) upon observing the situation together with the addressee, examples (156) to (162) in 3.4.1. For the same reason, shared activities may also be marked with the GEM, examples (164) to (166) in section 3.4.2. These usages are related to the perhaps most common usage of *inok* & siblings, namely to indicate shared or shareable knowledge, when explaining something to somebody who doesn't know, or when talking to persons about things or general facts they actually know well or could have known themselves, examples (167) to (189) in section 3.4.3 and example (214) in section 3.4.4. This may sound paradoxical, but in both contexts, the speaker focuses more on the addressee's potential knowledge state and interest, than on his/her own experience and knowledge type. A special generalised perfect construction, serving similar generic functions, seems to be just developing across the dialects, examples (163) to (214) in section 3.4.4.

In a less elaborate system than Ladakhi, one might call the GEM or any form with similar functions a marker for de-personalised knowledge. However, I shall reserve the latter term for a special combination of verb plus nominaliser plus GEM, which is found in the Kenhat dialects of the central area and Zanskar, and, with a slightly different structure in negation, in the dialect of Teya (eastern Sham). This DEPERSONALISED GENERIC KNOWLEDGE MARKER (DPG) is shown in examples (215) to (219) in section 3.4.5. Its original epistemic function shows up in examples (221) to (223). In the Zanskarpa dialect of Faḍum, the DPG appears infrequently for first person habits and planned activities, examples (224) to (227) in section 3.4.6. The DPG can also be used for emotionally loaded assertions concerning the speaker, examples (228) and (229) in section 3.4.7.

In contrast to the markers for sense perception or the markers for non-experiential authoritative knowledge, *inok* & siblings, in their generalised function, signal that one does not (want to) claim exclusive personal knowledge (even if one has). *inok* & siblings are thus common in polite speech and questions. In contrast to the markers for non-experiential authoritative knowledge, they may signal that one is (or expects the addressee to be) open for discussion; see particularly the contrast in (178). These generalised evaluative usages are much less developed in the Baltipa and Purikpa dialects, where *in(t)suk* is used mainly as inferential marker or as marker of just coming to know. Nevertheless, some such usages are attested for the copula use in the Eastern Purikpa dialects of Ciktan, Wakka, and Mulbek, examples (91), (92), (107), (108), (127), (136), (157), (182) to (184), and even in the Western and Southern Purikpa dialects and in the dialects of the Turtuk area, examples (89), (90), (106), (116), (126), (151), (167) to (172), and (185).

The above-mentioned functions and contexts are summarised once more at the beginning of the next section. Wherever possible, examples for the use of *inok* & siblings as a copula will precede those where they function as auxiliary. The order of the examples will largely follow the distribution of dialects from the north-west to the south-east, compare the order in Table 6, above p. 26.

Since I am aware that the more widely received descriptions of the Ladakhi dialects (Koshal 1979 for Central Ladakhi and Zemp 2018 for the Purikpa dialect of Kargilo) may lead to the conclusion that the Western Shamma combination *intsok*, due to its similarity with the Purikpa marker *in(t)suk*, only expresses an inference, never generic facts, and that, by contrast, the Lehpa combination *inok* has no inferential value,⁵⁷ the examples will not be balanced, that is, there will be more examples of *inok* and its Kenhat siblings for the inferential contexts and more examples of *intsok* for non-inferential contexts in the Western Shamma dialects. Having met with strong objections by Rev1 concerning the functional comparability of the markers in question, I shall assemble examples from as many different dialects as possible for similar and comparable or even exactly the same contexts. Readers are kindly requested to pardon me for the ensuing repetitiveness.

3 The manifold usages of *inok* & siblings

The multiple usages *inok* & siblings can be roughly sorted according to their underlying epistemic and socio-pragmatic functions into four categories.

- usages that correspond to the original epistemic, inferential, and/ or admirative value (section 3.1), namely inferences (section 3.1.1), identifications through sense perception (section 3.1.2), sudden realisation of unexpected facts (section 3.1.3), and, perhaps as a special case of the foregoing, the unveiling or realisation of identities and other facts in narrations (section 3.1.4); in combination with a gerundive construction, *inok* & siblings are further used for assumptions about future situations (section 3.1.5);
- irrealis usage (section 3.2); apart from the infrequent use of the GEM as copula for conditioned assumptions (section 3.2.1), it appears particularly for children’s play roles (or stage directions) (section 3.2.2), imagined situations in explanations (section 3.2.3), and for planning and suggesting (section 3.2.4);
- usage according to social conventions (section 3.3), namely expressions of mental distance or non-involvement (section 3.3.1), matters of status and authority (section 3.3.2), gentle speech to small children (section 3.3.3), asking about the identity of absent persons (section 3.3.4), statements about the addressee’s non-ownership while owning the item oneself (section 3.3.6), expression of shyness or shame (section 3.3.7), sarcastic speech (section 3.3.8), and other emotional usages (sections 3.3.9 and 3.4.7);
- and the most neutral, so-to-speak ‘factual’ usage (section 3.4), namely for shared observations (section 3.4.1), shared activities (section 3.4.2), explanations concerning shared and shareable knowledge (section 3.4.3), generic facts and explanations presented with a special perfect construction (section 3.4.4), generic facts presented with the Central Ladakhi and Zanskarpa construction for depersonalised knowledge (section 3.4.5), and first person habits and planned activities, likewise presented with the construction for depersonalised knowledge in the Zanskarpa dialect of Faḍum (section 3.4.6).

Only the first two groups correspond to the more original non-confirmative, epistemic value. This value has been exploited for socio-pragmatic hedging or a downgraded stance in the third and

⁵⁷ Note, however, that Bielmeier (2000: 95) classifies the element *-ok* as inferential, while only Koshal (1979: 188) describes the compound form as used “for general statements, statements of universal application, historical truth etc.”

fourth group. With this extended or overgeneralised usage, the epistemic function has bleached out to a greater or lesser extent.

3.1 *Usages with an epistemic value*

3.1.1 *Inferences*

The Ladakhi dialects have various specialised epistemic evaluative markers. They typically contain an element *-uk/-ok/-ak* that ultimately goes back to the admirative existential linking verb *hdug*. The Shamskat inferential-*cum*-distance marker *-suk/-sok* combines with the copula *in* (<*yin*) to form the GEM, but also with the existential linking verb *jot* (<*yod*), and thus also with the non-continuative present tense forms. It further follows the past stem. The Lalokpa element *-dak* follows the copula and auxiliary *hin* and the existential linking verb *hot*, but not the existential auxiliary. The element *-ok/-ak* of the Kenhat GEM is even more restricted. It can only follow the copula *j̄in* ~ *hin* (and the verb stem for a future inferential). In the Kenhat dialects, only the respective distance or probability markers can be used with the non-continuative present tense constructions. However, the GEM may be used with the present perfect as in (18) and (19), with the continuative present tense construction as in (22) and with the prospective construction as in (66). The GEM further appears in another Kenhat construction, which once was a future inferential, but has bleached out to a comparatively neutral DEPERSONALISED GENERIC KNOWLEDGE MARKER (DPG) (see section 3.4.5).

The Kenhat past tense ‘inferential’ marker is *-tok* (with or without assimilation) or *-tuk* (with assimilation) in the Kenhat dialects, while the Shamskat dialects and the Baltipa-Purikpa dialects use the less specific inferential-*cum*-distance marker *-suk/-sok*. Both markers follow the verb stem and are derived from a perfect construction involving the auxiliary *hdug* with its original admirative function (Zeisler 2017a). Both markers are used when one has not personally observed a past situation, but has some kind of relatively immediate perceptual input that leads to the conclusion.⁵⁸ They may also be based to a certain extent on some unspecific hearsay knowledge.⁵⁹

When the evidence is more intricate or complex or when the situation is temporally more distant, special markers for mental distance, the Kenhat distance markers: *-kjak*, *-ka(no)k/-ka(na)k/-ka(nda)k* and the Shamskat complex distance marker *-kha(ji)ntsuk* are used, which likewise follow the verb stem and the linking verbs or auxiliaries. The Lalokpa dialects further display an apparently more neutral past indirect marker *-pak*. Further combinations, such as *-Bintsuk* or *-Ga(i)ntsuk* may be used as past or narrative distance markers in various dialects, see again Table 3 above.

⁵⁸ Hengeveld & Hattnher (2015: 486) have chosen the rather misleading term ‘deduction’ for this, reserving the term ‘inference’ for merely mental reasoning. The latter is termed ‘assumption’ by Aikhenvald (2014: 9) in contrast to ‘inference’ based on perceptual evidence. One may further want to differentiate between mere assumptions or rather guessings and logical reasoning, as in philosophical and scientific discourse.

⁵⁹ Given this application for unspecific hearsay knowledge, the term ‘indirect knowledge marker’ might be more appropriate. However, according current terminological usage, this would include all kinds of hearsay and quotation as well as the functions of the Ladakhi distance markers. Since this would be even more misleading, I follow here roughly the decisions of Koshal (1979: 216), who uses the term ‘attested inferential’ for the marker *tok*, of Ghulam Hassan Lobsang (1995: 44), who, with the advice of Roland Bielmeier, uses the term ‘inferential’ or *graphshat tanmo* for the marker *-suk* in the Eastern Baltipa dialect of Kharmang, and of Zemp (2018), who uses the term ‘inferential’ for the Kargilopa marker *-suk*. The term ‘past indirect’ is reserved here for the Lalokpa marker *-pak*.

Given the prominent inferential function of the morphemes involved, it is not at all surprising that the combination with the copula may itself have an inferential value, competing with the more specialised evaluative markers just mentioned. In the Purikpa dialects, the inferential function appears to be the dominant function and almost the only function in the more complex auxiliary constructions. In the Baltipa dialects of the Turtuk area, *in(t)suk* is commonly used for having come to know, very frequently also through hearsay knowledge.

In order to better compare the respective inferential usages, I developed some contexts that were tested with all informants as far as possible. One of them was the story of a fictive thief among a speaker's fictive three friends. When testing the story with female informants, the three friends were mostly female, and the stolen item was something smaller, like a precious watch or the precious amulet that women are wearing on festivities. When testing the story with male informants, the three friends were male, and the item stolen was usually a car or, in the case of an elderly informant from the nomad area, a horse. In all settings, it was established in the narrative that nobody except the three friends knew about the item and/ or the place where the item was kept. In all settings, two of the friends had either gone to another town two days before the theft occurred or had gone trekking, where they broke their leg(s), and were similarly ruled out as the potential thief. In all settings, the third friend had no such excuse, and could thus be identified through reasoning as the thief.

Depending on the assumed amount of reasoning, the informants used either the GEM or a distance marker, the former indicating a more immediate process of becoming aware as well as high certainty, the latter indicating a more complex process of weighing the various bits of information, and usually also indicating a certain residue of doubt. Prospective constructions, on the other hand, indicate a medium degree of probability or even mere guessing.

In example (13), there is the alternative solution that the thief is not identified through the speaker's reasoning, but has been caught by the police. The identification thus comes as a big surprise, marked with the mirative distance marker.

I shall reproduce here only the last part of this story, omitting also the alternative verbal form of the conclusion, that the third friend *must have stolen* the item. This latter statement typically involves the distance markers.

(11) Sankoopā (Southern Purikpa, field data 2022)

dekana ŋa(:) fak soŋ, ta :
 then I+AES suspicion go.PA now
ja rasul, ja ali, ja amir di sump+iaŋna ŋiktŋig-is kher-e-in.
 or Rasul, or Ali, or Amir this three+PPOS one-ERG take.away-LB-CP=ASS.PERF
dekana ali haj-la soŋ-se-met-pin.
 then Ali haj-ALL go.PA-LB-NG.EX-RM=ASS.PERF.NRS⁶⁰
amir srinagar-la sil-ba+(:) soŋ-se-met-pin.
 Amir Srinagar-ALL study-NLS+ALL go.PA-LB-NG.EX-RM=ASS.PERF.NRS
rasul-tsa khaŋma-a jot-pin.
 Rasul-only home-ALL exist.ASS-RM
defarpos rasul ŋkunma in-tsuk.
 therefore Rasul thief be-INF/DST

⁶⁰ The combination is ambivalent between a negated perfect 'not having gone' and a 'perfect of negative result' emphasising the disappearance or complete destruction of the item transformed, here that the person was no longer there. The perfect of negative result is formed with all three negated existential auxiliaries: *yod*, *ħdug*, *rag*.

‘Then I got suspicious: either Rasul or Ali or Amir, one of the three (friends) had taken it away. [But] then, Ali had gone for the *haj*, Amir had gone to Srinagar in order to study; only Rasul had been at home. Therefore, Rasul **must be/ must have been** the thief.’

- (12) Sumurpa (Shamskat, Ldumrapa, field data 2016)

ote+(:)ṛṇṅāo aṅṅfuk dilli-a soṅ-s-aṅ.
 that.very+PPOS Angcuk Delhi-ALL go.PA-LB+VIS=PERF
jaṅ Sonam-e kama ṅhak-s-aṅ.
 again Sonam-GEN leg get.broken-LB+VIS=PERF
defia dorḅe skunma intsuk.
 therefore Dorje thief be=GEM

‘Before that [happened], Angcuk went to Delhi and Sonam broke his leg. Therefore, Dorje **is/ must be** the thief.’

- (13) Rumbakpa (Kenhat, Central Ladakhi, field data 2017)

ta ṅhuskit kaṅoaṅ masoṅ, inaru jot-pin.
 now Chuskit anywhere NG-go.PA here.exactly exist.ASS-RM
tene tantan kho skunma inok. /
 then certain s/he thief be=GEM
zak khafṅig-estiṅna polus-e ṅ-e kau tsal-te, khjoṅs-pa,
 day some-PPOS:ABL police-ERG I+GEN amulet search-LB bring.PA-NLS
skunma-o ṅhuskit in-tsok. kho in-a ta mane ma-sam.
 thief-DF Chuskit be-MDST s/he be.ASS-QM now ever NG-think

Now, Chuskit did not go anywhere; s/he had been right here. Then [it is] **certain: s/he is/ was** the thief. / Some days later, the police searched for the amulet, and when [they] brought [it back], (it turned out that) the thief **was, to my surprise**, Chuskit! I would have never thought that she was [the thief].’ (The mirative distance marker signals complete surprise, hence it cannot be used in the context of reasoning, because, according to the informant, in the process of reasoning a certain expectation builds up.)

- (14) Kyungyampa (Kenhat, Upper-Indus, field data 2017)

dikid-la tetso[g]-e ṅāt me-rak.
 Dikit-AES that.like-GEN excuse NG-have.NVIS
ṅ-e ṅāim tōr-zane, ṅaḅ-e te-ne hot-pen.
 I+GEN watch get.lost-when we.excl+GEN that-ABL/LOC exist.ASS-RM
*teṅe kho kūnma ṅin-ṅe-rak. / ṅinak. / *ṅin-kak.*
 then s/he thief be-GRD-NVIS=PROSP be=GEM *be-DST

‘Dikit had no such excuse (I think). When my watch disappeared, she had been in our place (lit. in our that). Then she is possibly / **is certainly** the thief.’

- (15) Gyerepa (Kenhat, Upper Indus dialects, field data 2018)

teṅe ṅ-e samba tā-fen.
 then I+ERG thought give.PA-RM=ASS.PA
tā tōr-esoṅ zak sum-eṅonla
 horse disappear-CNTR day 3-PPOS
aṅṅcuk dili-a ṅoṅtan lāb-a soṅ.
 Angcuk Delhi-ALL education learn-NLS.ALL go.PA

jaŋ t̄āci tr̄ēkiŋ-a soŋ-te, t̄ag-ekane t̄et-e,
 again Tashi trekking-ALL go.PA-LB rock-PPOS:ABL slip-LB
kāmpa t̄hak, jaŋ kho mānkaŋ-a kher.
 leg get.broken=PA again s/he hospital-ALL take.away=PA
t̄a t̄oŋdup t̄eikpo māne mā-ly.
 now Tondup alone except NG-be.left=PA
kho-a itsoy-e j̄ēt t̄e-āŋ m̄et.
 s/he-AES this.like-GEN excuse what+FM NG.have.ASS
t̄ene kho kūnma j̄in-kak / j̄indak sam.
 then s/he thief be-DST be=GEM think=PA

Then I thought about it. Three days before the horse disappeared, Angcuk had gone to Delhi for further education. Also, Tashi had gone trekking and, slipping from a rock, [he] had broken [his] leg and was taken to a hospital. Now there is/ was only Tondup left. He had no such excuse. Then I realised (lit. thought): he must have been / he **definitely was** the thief. (The distance marker conveys a notion of doubt. / The GEM indicates a **certain conclusion**.)

A few informants preferred the distance marker to the GEM for an inference based on mere reasoning. The GEM could be used, however, for an inference drawn upon immediate visual input, (17), alternative b.

- (16) Shachukulpa (Kenhat, Lalokpa, field data 2016)

ŋ-e kār kū-i kher. [...]
 I+GEN car steal-INSTR take=PA
dorze, kāŋba ŋhak-te, zak sum-ne haspaṭal-a hot.
 Dorje leg break-LB day three-ABL hospital-ALL exist.ASS
aŋfuk zak j̄n̄ j̄n̄la dilli-a soŋ.
 Angcuk day two earlier Delhi-ALL go.PA
*t̄ene riŋzin kūnma j̄in-kak. / *j̄indak. ŋa-(:) heran soŋ.*
 then Rigzin thief be-DST *be=GEM I+AES surprised become.PA

‘My car got stolen. [...] Dorje had already been three days in the hospital with a broken leg. Angcuk had gone to Delhi two days before [the theft]. Then Rigzin must be the thief. What a surprise!’

- (17) a. Mūtpa (Kenhat, Tibetan border dialect, field data 2018)

n̄r̄bu-a t̄e-zane t̄e-aŋ l̄e m̄et-pin. k̄arua soŋ-te-m̄et.
 Nurbu-AES that-when what+FM work NG.have.ASS-RM where go.PA-LB-NG.EX=ASS.PERF.NRS
t̄e kho j̄in-kak, kūnma-re. jaŋ su-aŋ kher-çi-man.
 then s/he be-DST thief-DF again who-FM take.away-GRD-NG.CP=FUT

‘Nurbu had no [particular] job at that time. He did not go anywhere. So then, it was/ must have been him, that thief [of the car]. Nobody else would have taken [it].’ (The distance marker is used for a conclusion based on inference and reasoning.)

- b. Mūtpa (Kenhat, Tibetan border dialect, field data 2018)

n̄r̄bu-a t̄e-zane t̄e-aŋ l̄e m̄et-pin. k̄arua soŋ-te-m̄et.
 Nurbu-AES that-when what+FM work NG.have.ASS-RM where go.PA-LB-NG.EX=ASS.PERF.NRS
t̄e kho j̄indak : ŋ-e galqi ŋa-(:) kh+ø ṣul-a thoŋ.
 then s/he be=GEM I+GEN vehicle I+AES s/he+ERG drive-NLS see=PA

tɛ kho künma jindak!
 then s/he thief be=GEM

‘Nurba had no [particular] job at that time. He did not go anywhere. So then, it **was (evidently)** him: I saw him driving my car. So then, he **was** the thief! (What a **surprise**).’ (The GEM in the first part indicates that the speaker has definite [immediate] evidence; in that case, some visual input. The GEM in the last sentence expresses sudden realisation and surprise.)

The GEM in its inferential or assumptive function appears also in constructions that allow a copula as auxiliary, namely the perfect, examples (18) to (20), and the prospective construction, example (21) and examples (64) to (69) in section 3.1.5, less frequently also in the marked continuative present tense construction, example (22).⁶¹ As already mentioned, when appearing as an auxiliary for complex tense constructions, *intsuk* does not develop into a generalised evaluative marker in the Purikpa dialects. So far, I know of only few exceptions to this (see examples (89) to (92) in section 3.2.4 and example (185) in section 3.4.3).

- (18) Ciktanpa (Shamskat, Eastern Purikpa, field data 2016)

ŋ·i zosta rtsokpo soŋ-se-in-tsuk.
 I+GEN appearance bad/dirty go.PA-LB-CP=PERF-INF/DST

‘I must look ugly. (Lit. My appearance **must have become** ugly.)’ (Inference, e.g., because somebody stares at me in a strange way.)

- (19) Domkharpa (Shamskat, Western Shamma, field data 2014)

kho khjaks-e-intsok.
 s/he freeze-LB-GEM=PERF

‘S/he **is freezing** (as I can **infer** through visual input).’

- (20) Lingshetpa (Shamskat, Southern Shamma, field data 2016)

di ige-wo ŋa-s qi-se-nok.
 this letter-DF I-ERG write-LB+GEM=PERF

‘This letter **is apparently written** by me’ (The speaker recognises the handwriting).’

- (21) Faḍumpa (Kenhat, Central Zanskarpa, field data 2019)

milarepa goma yergan tsal-zane, tene yergen-e «pene toŋ!» mol-ka?
 Milarepa first teacher search-when then teacher-ERG money give.IMP hon.say-DST
tene milarep·e sam-ka?
 then Milarepa·ERG think-DST

⟨*yergan su-zi?* *hin-na, pene ma-yø-hen-zi?* *mi-ndu?*⟩
 teacher who-LQ be-CD money NG-need-NLS-LQ NG-exist.VIS

ta ŋa·(:) pene met; ʃhøe thop-ʃe-ma? *sam-ka?*
 now I+AES money NG.have.ASS religion obtain-GRD-NG.GEM think-DST

‘In the beginning, when Milarepa was searching a religious teacher, then the teacher said: «You have to pay money!» Then Milarepa thought: «Whichever teacher it may be, one that would not ask for (lit. want) money (apparently/ evidently) does not exist. Now, I don’t

⁶¹ The combination with the continuative present tense construction does not appear to be very frequent. I have one example for the Mulbekpa dialect with an inferential value. I am lacking clear examples from the western Shamma dialects. In the Kenhat dialects, on the other hand, the combination of a continuative present tense with the GEM is mainly used for explanations or shared knowledge.

have [any] money. [So] I (**probably**) **won't obtain** the religious teaching(s).' Compare also example (230), from the *Mi.la.ras.paḥi rnam.thar*, below section 4.1.

- (22) Gya-Mirupa (Kenhat, Upper Indus dialects, field data 2015)
duktʃhen rinboḥhe-se gonba nīḅba tshaḅma-(.)
 Drukchen rinboche-ERG monastery old all-ALL
zikso ʃē-ze thug-a goḅ-en-inak.
 repair do-NLS hon.heart-ALL hon.consider-CNT-GEM=CNT.PRS
 'The Drukchen rinboche **is apparently thinking** of repairing the old monasteries.' (The speaker infers this from frequent utterances of the rinboche.)

3.1.2 Identification through sense perception

Unlike attributes, identities are somewhat abstract and cannot immediately be perceived. Some kind of inference is involved when one does not already know the identity of an item but perceives something *as* something. For most people, this inference goes unnoticed when a visual perception is involved, but the Ladakhi speakers are more sensitive and use the GEM instead of the plain copula. When other perceptions are involved (and vision is excluded) one might be more aware of the mental process or one might feel less sure about the identification. Hence, the Ladakhi speakers use another marker, the SEM, which is derived from the auxiliary for non-visual perception *rag*. See again Table 6 above for the two markers (and their apparent etymological relationship) and Table 7 above for their negated forms.

Speakers of the Baltipa dialects tend to use the combination with the experiential marker *snaj*, (23) to (25) for all senses. According to the Tyaksipa speaker, the combination with the inferential-*cum*-distance marker *in-tsuk* points to the past. It is thus common for a slightly delayed realisation 'it turns out to be' with or without a connotation of surprise, (25). It has also been observed for a – perhaps not very seriously made – self-identification in a visual representation (26). (Speakers of the western and southern Purikpa dialects would similarly use only one form, namely *in-(t)suk*, for all senses.)

- (23) Dialect of Ghanche District (?)⁶² (Eastern Baltipa, Jones 2009: 53, ex. 35a, adapted)
rkunma, badf-i khar ʃaq-khan-po khjan in-maj.
 thief king+GEN palace break-NLS-DF fam.you be-EXP
 'Thief! You **are** the person who broke into the king's palace.' (**Identification through non-visual sensory input**: "the police discover who the thief is because he smells of perfume".)
- (24) Dialect of Ghanche District (?) (Eastern Baltipa, Jones 2009: 53, ex. 34, adapted)
dju ɣa men-maj.
 this I NG.be-EXP
 'This **isn't** me.' (**Identification through visual sensory input**: upon being shown a photograph of oneself.)

⁶² Jones does not specify her data, but she contrasts the Ghanche district, where the forms she describes are still spoken, with the Skardu district where some of these forms have been lost (Jones 2009: 39 with n. 33).

- (25) Turtukpa (Eastern Baltipa, field data 2017)
*gj+u*⁶³ *kuf+i* *džus in-manj*.
 this+DF apple+GEN juice be-EXP
lekin gj+u džus men-tsuk. gj+u fhu in-tsuk!
 but this+DF juice NG.be-INF/DST this+DF water be-INF/DST
 ‘This is apple juice (as I **can see**). But (unexpectedly/ as it turns out) this is not juice! This is/ turns out to be [only] water!’ (Here the first statement is only based on vision, hence the surprise when actually tasting the drink. The same form *in-manj* would be used if the identification were solely through tasting in a neutral context without any particular expectation or when expectation and identification match. The form *in-tsuk* points to a delayed, and in this case, surprised realisation, based on a non-visual input, but it would be also used if this realisation were based on visual input.)
- (26) Tyaksi-Thangpa (Eastern Baltipa, field data 2022)
kho xerun in-tsuk.
 s/he Kherun be-INF/DST
 ‘That one **is** Kherun.’ (Kherun said this while **looking at a selfie** in the smartphone.)
- (27) Ciktanpa (Shamskat, Eastern Purikpa, field data 2016)
du fhan intsok. / inđak.
 this+DF chang be=GEM be=SEM
 ‘This is *chang* (the local beer) (as I **can see** [and judge from the colour] / as I can [judge from the] taste).’
- (28) a. Tagmacikpa (Shamskat, Western Shamma, field data 2019)
d+u ra+fik intsok.
 this+DF cotton+LQ be=GEM
 ‘This **is** cotton (as I **can see and feel** or as somebody told me.)’
- b. Tagmacikpa (Shamskat, Western Shamma, field data 2019)
d+u ras inđak.
 this+DF cotton be=SEM
 ‘This is cotton (as I can only feel).’ (Visual input is either excluded, as when identifying the cloth in darkness or blindfold, or it is not sufficient for the identification.)
- (29) Lingshetpa (Shamskat, Southern Shamma, field data 2016)
d+u fhan inok. / d+u ŋati fhan inak.
 this+DF chang be=GEM this+DF we.incl.GEN chang be=SEM
 ‘This **is** *chang* ([as I **can see**] upon judging the colour). / This is our *chang* (tasting it blindfolded.)’

⁶³ The replacement of initial *d-* of the demonstrative pronoun by *g-* is a particular feature of the dialects of the Turtuk area. It is attested regularly for the proximate demonstrative pronoun *di > gi* (*giu ~ gju* with definiteness marker), also in compounds such as *giring* ‘today’ and *gjufik ~ gjuik* ‘this year’, cf. Western Shamma *dufik*. Infrequently, the replacement also appears with the remote demonstrative *de > ge*, and somewhat more frequently as *gjo* with definiteness marker in the compound *gjotsoks* ‘that way’. By contrast, as mentioned by the Tyaksipa speaker, some persons, who are apparently aware that this velar consonant is ‘wrong’, may use the wrongly ‘corrected’ form *dilas* for *gilas* ‘glass’. The reason for this replacement and the restriction to the demonstrative pronouns is not apparent.

- (30) Shachukulpa (Kenhat, Lalokpa, field data 2016)
i magmal fiindak. / finrak.
 this velvet be=GEM be=SEM
 ‘This **is** velvet (identified through **vision**). / This is velvet (identified through touching).’
- (31) Pangipa (mixed variety, Himachal enclave, field data 2017)
di yhu menne, farbat jinne.
 this water NG.be=GEM wine be=GEM
 ‘This **is not** water, this **is** wine.’ (In this case, the identification could be **through taste as well as through vision**.)

In this context of inferred identification via sense perception, one could possibly translate the GEM as ‘it looks like’ and the SEM as it ‘tastes like’ or ‘it feels like’, in order to show the senses involved. However, other than these latter translations, the constructions with the GEM and the SEM do not convey a connotation of uncertainty or hedging. Hedging along the line of the latter translations is conveyed by the construction *ts(h)ok+fik* ‘somewhat like’ plus the corresponding auxiliaries *duk* or *rak*. For the combination with *rak*, cf. the alternatives of example (32), for the combination with *hdug*, cf. the alternatives of example (33), which may be uttered when seeing the person in question from far.

- (32) a. Tagmacikpa (Shamskat, Western Shamma, field data 2019)
daksa rilqi+(:)aŋ joŋ-khan-i meme ŋaf+i meme inqak.
 now radio+PPOS come-NLS-GEN grandfather we.excl+GEN grandfather be=SEM
 ‘The old man (lit. grandfather) who can be heard (lit. is coming) in the radio [right] now, is our grandfather (I am sure, I **know/ recognise his voice**).’
- b. Tagmacikpa (Shamskat, Western Shamma, field data 2019)
daksa rilqi+(:)aŋ joŋ-khan-i meme
 now radio+PPOS come-NLS-GEN grandfather
ŋaf+i meme in-khan-tsok-fik duk.
 we.excl+GEN grandfather be-NLS-like-LQ be.NVIS
 ‘The old man (lit. grandfather) who can be heard (lit. is coming) in the radio [right] now, sounds as if [he] were our grandfather.’
- (33) a. Lingshetpa (Shamskat, Southern Shamma, field data 2016)
kho ŋati khimtsespa inok.
 s/he we.incl.GEN neighbour be=GEM
 ‘S/he is our neighbour ([as I can **see**]; I am sure, without doubts).’
- b. Lingshetpa (Shamskat, Southern Shamma, field data 2016)
kho ŋati khimtsespa-tsok-fik duk.
 s/he we.incl.GEN neighbour-like-LQ be.VIS
 ‘S/he is/ looks like our neighbour ([I am not fully sure]).’

More generally, the GEM is regularly used when identifying a person from far, even if this may be a family member. Exceptions would be made only if one already knew that the person was coming that way, (35). One informant described this use of the GEM as indicating a longer process of recognition or, in other words, of reflection, (36).

- (34) a. Turtukpa (Eastern Baltipa, field data 2017)
e jot-p+e d+o ŋa+i ata in.
 over.there exist-NLS+GEN that+DF I+GEN father be.ASS
 ‘The one who is over there is my father.’
- b. Turtukpa (Eastern Baltipa, field data 2017)
e thagriŋ jot-p+e d+o ŋa+i ata in-maŋ.
 over.there far exist-NLS+GEN that+DF I+GEN father be-EXP
 ‘The one who is **over there in the distance is (apparently)** my father.’
- (35) Ciktanpa (Shamskat, Eastern Purikpa, field data 2017)
e+(.)kana joŋ-khan-po ama in. / intsuk.
 that+PPOS:ABL come-NLS-DF mother be.ASS be=GEM
 ‘The person coming from over there is / **is (apparently)** [our] mother.’ (Upon seeing a well-known person from far. The plain copula indicates that one knew beforehand that the mother was coming that way. / The GEM indicates that one is **just seeing** [and recognising] her).’
- (36) Gyerepa (Kenhat, Upper Indus dialects, field data 2018)
phai-ne hoŋ-kan-de ŋ+e nāa jīn. / jīndak.
 over.there-ABL come-NLS-DF I+GEN wife be.ASS be=GEM
 ‘The one who comes from over there is / **is (apparently)** my wife.’ (According to the informant, the plain copula indicates that one recognises the person immediately. / The GEM signals that “**it takes a little time to recognise her**”.)
- (37) Pangipa (mixed variety, Himachal enclave, field data 2017)
tharim-ke joŋ-en ŋ+e da?p jīnne.
 far-ABL come-CNT I+GEN husband be=GEM
 ‘The one who is coming from far [over there] **is (apparently)** my husband.’

A slightly different usage has been observed in the Faḍumpa dialect. Here, another factor comes additionally into the play, namely, whether or not the addressee already knows the person:

- (38) a. Faḍumpa (Kenhat, Central Zanskarpa, field data 2022)
a-kane jō-hen-bo ŋaʒ+e ama ino? / in.
 over.there-PPOS:ABL come-NLS-DF we.excl+GEN mother be=GEM be.ASS
 ‘The one who is coming from over there is our mother.’ (The GEM is used a) if the speaker **just recognises her**, and b) when the **addressee is expected to know**. / The plain copula is used [if the speaker was aware of the coming before hand] and the addressee does not know her.)
- b. Faḍumpa (Kenhat, Central Zanskarpa, field data 2022)
ika duk-kan-bo ŋ+e ama %ino? / in.
 here sit-NLS-DF I+GEN mother %be=GEM be.ASS
 ‘The one sitting here is my mother.’ (As the person is fully in view, the speaker would not need time to recognise her; the GEM might be used when the addressee already knows her. / Only the plain copula can be used when the addressee does not know her yet.)

Similar examples are also found in other Tibetic languages. The Amdowa dialect of Mabzhi shows the use of the factual marker *red* for identifications through sense perception. Note that in the latter dialect, according to Suzuki & al. (2021: 87), the factual marker has the alloforms *re* and *rə* plus two compound forms *re-ko-o* (most likely from *red-gyi-yod*) and *jən-nə-re* (*yin-NLS-red*),

while the marker used for identifications via sensory input takes only the form *re*.⁶⁴ Unlike the authors, I do not think that we deal here with two different copulas, but only with two different functions of a single copula.

- (39) Dialect of Mabzhi (Amdo, Suzuki & al. 2021: 89, ex. 49a, slightly adapted)

ndə fha re.

this meat be.SENSORY

‘This **is** [evidently] meat (not vegetables).’ (Situation: The speaker has **recognised** the meat by **tasting or looking**.)

The dialect of Choswateng in Kham allows for the differentiation between visual and non-visual input, quite like the Ladakhi dialects. In the case of identifications via sense perceptions, there is similarly a compound form based on an alloform of *yin*: *zê* (in the compound: *zê-*), which is either a phonological variant of *yin* or of unknown origin, plus the visual existential marker *ŋɔ̃* (<*snaŋ*): *zê-ŋɔ̃* for the visual inference. The non-visual inference may be expressed either by a simplex *caʔ* (<*grags* (?)) or a compound form *zê-caʔ*. Interestingly enough, in this dialect, the non-visual existential is a compound form based on *yod*: *jûʔ-caʔ*. (Tones are marked as follows: *á* rising, *à* falling, *â* rising-falling, and *ā* high-level.)

- (40) a. Dialect of Choswateng (Kham, Suzuki & al. 2021: 83, ex. 19, slightly adapted)

ndjə pómə zêŋɔ̃.

this girl be.VIS.SENSORY

‘This **is** [evidently] a girl.’ (Situation: There is a child coming to the speaker, who **just realises** that the child is female.)

- b. Dialect of Choswateng (Kham, Suzuki & al. 2021: 82, ex. 1e, 83, ex. 21, adapted)

ndjə ʔáraʔ cáʔ. / zêcaʔ.

this alcohol be.NVIS.SENSORY(simplex) be.NVIS.SENSORY(compound)

‘This **is** [evidently] an alcoholic drink.’ (Situation: After the speaker drank transparent liquid.)

In Standard Spoken Tibetan, by contrast, the combination *red* & *hdug* may be used for an *ad-hoc* identification upon visual input:

- (41) Standard Spoken Tibetan (Garrett 2001: 91, ex. 32, adapted)

khoñ dge.rgan red.hdug.

hon.he teacher INDIRECT.COPULA.DIRECT.EXISTENTIAL

‘I **see** he’s a teacher.’

3.1.3 Sudden realisation: surprising situations or counter-expectations

Given the use of the inferential-*cum*-distance marker *-suk/-sok* also for unexpected situations, the combination with the copula naturally appears in contexts of identifications against one’s expectations in the Eastern Baltipa, Eastern Purikpa, and Western Shamskat dialects. In the Turtukpa dialect, the mirative function remains with the inferential-*cum*-distance marker, and is not transferred to the experiential marker. In the Western Shamskat dialects, the mirative function can no

⁶⁴ The compound *yin.na.red* appears also in other Amdowa dialects (cf. Haller 2004 and Tribur 2019). The available descriptions do not point to a significant functional difference between the simplex form *red* and the compound form *yin.na.red*. The compound *red.gyi.yod*, could perhaps correspond to the Ladakhi (past) distance markers.

longer be separated from the generalised (non-experiential, non-inferential, non-mirative) functions. The Eastern Purikpa dialects may be seen as taking a position half way between Western Shamskat and Eastern Baltipa.

The mirative sub-function of the inferential-*cum*-distance marker has spilled over into most Kenhat dialects, where *-suk/-sok* is used as a specialised mirative distance marker. Only few Kenhat speakers make use of *inok* and its Kenhat variants in mirative contexts.

Whatever form is chosen, one can always add an emphatic marker *-pa* (and variants), which emphasises one's emotional involvement. The notion of surprise does not depend upon the use of this marker.

- (42) Turtukpa (Eastern Baltipa, field data 2017)
dai tshan-la ŋa go-a-na, ŋ-idunpeka kunm+e-ŋik jot sam.
 recent night-ALL I go-NLS-ABL I+PPOS thief+GEN-LQ⁶⁵ exist.ASS think=PA
*dena ŋa dun-p+i thon-ma-na lŋaŋm+e-ŋik in-tsuk. / *in-maŋ.*
 then I front-DF+GEN arrive-NLS-ABL tree+GEN-LQ be-INF/DST *be-EXP
 'A short while ago, when I was out (lit. going) in the night, I thought there was a thief ahead of me. [But] when I came in front [of that being], it **was/ turned out to be** [only] a tree.'
- (43) Ciktanpa (Shamskat, Eastern Purikpa, field data 2017)
o khjaŋ ɖagɖar ldan-tsuk! / intsuk!
 intj fam.you doctor become-INF/DST be=GEM
ŋas sams khjaŋ tɪŋhar ldan-ŋ-en.
 I-ERG think.PA fam.you teacher become-GRD+CP=FUT
 'Oh, you have become / you are a doctor! (This is **totally unexpected**!) I thought you would become a teacher.'
- (44) Lingshetpa (Shamskat, Southern Shamma, field data 2016)
ŋa-s sam-et-pin nakf-er̄kila dorɖe in. inaŋ ŋaraŋ inok.
 I-ERG think-EX-RM=ASS.IMPF picture+PPOS Dorje be.ASS but I.self be=GEM
 'I had thought the one in the middle of the picture was Dorje, but it is me (as I **just realise**).'
- (45) Pangipa (mixed variety, Himachal enclave, field data 2017)
ŋ-e sam : kho thede in, sam. inaŋ kho kjalon jinne.
 I+ERG think=PA s/he goatherd be.ASS think=PA but s/he monk be=GEM
 'I thought he is/ was a goatherd, but he **is/ was/ turned out to be** a monk.'

In the context of surprise and counter-expectations, the Kenhat mirative distance marker stands in clear contrast to the ordinary Kenhat distance marker, which is frequently used for the situation that one actually expected. In the Central Ladakhi dialect of Rumbak, e.g., the ordinary distance marker is *-kjak*, like in Leh, but for the notion of counter-expectation, *-sok* is used, (46). In the Çarapa dialect, the ordinary distance marker is *-ka(na)k*, but in the context of counter-expectation or surprise *-suk* is used, (47), alternative a. The mirative distance marker is then also used in present tense constructions, (47), alternative b. In the Faɖumpa dialect, the ordinary distance marker is *-ka*², while the mirative distance marker is *-su*², (48), alternative a. The marker is accordingly also used in this dialect, when one realises a fact that one just did not expect or think of, (48), alternative b.

⁶⁵ Cf. Bielmeier (1985: 86) for this unexpected combination of GEN & LQ. It occurs only after open syllables. The genitive alone can take up the function of the LQ (see Ghulam Hassan Lobsang 1995: 9f.).

- (46) Rumbakpa (Kenhat, Central Ladakhi, field data 2017)
ŋ·e kho rardzi in-kjak sam. kho gergan-dzjik in-tsok.
 I+ERG she goatherd be-DST think=PA s/he teacher-LQ be-MDST
 ‘I thought s/he is/ was [only] a goatherd. [But] (**to my surprise**) s/he **is/ was** a teacher.’
- (47) a. Çarapa (Kenhat, Upper Indus dialects, field data 2016)
ŋ·e sam kho swiden-enāa hot-(kanak) sam.
 I+ERG think=PA s/he Sweden-PPOS exist-(DST) think=PA
hinaŋ taksa kho lē-ne hot-suk!
 but now s/he Leh-ABL/LOC exist-MDST
 ‘I thought s/he was in Sweden, but now s/he **is (unexpectedly)** in Leh!’
- b. Çarapa (Kenhat, Upper Indus dialects, field data 2016)
ŋ·e khjoraŋ gergan t̥e·fen.
 I+ERG fam.you teacher do·RM=ASS.PA
hinaŋ khjoraŋ endzio sul-at-suk-pa, ma(:) heran soŋ!
 but fam.you NGO run-EX-MDST-emp very surprising become.PA
 ‘I thought you were a teacher (lit. I did you teacher). But you **are running** an NGO (**as I realise**), this is a big surprise!’
- (48) a. Faḍumpa (Kenhat, Central Zaskarpa, field data 2019)
kho taʔpe gjyr-ḍe-jo-kaʔ sam. kho rarzipa-ziʔ hin-tsuʔ!!
 s/he strong become-LB-EX=PERF-DST think=PA s/he goatherd-LQ be-MDST
 ‘I thought s/he (might) have become a highly qualified (lit. strong) person, [but] (**to my surprise**) s/he **is** [only] a goatherd!!’
- b. Faḍumpa (Kenhat, Central Zaskarpa, field data 2019)
o: aba jō-ḍe-in-tsuʔ.
 intj father come-LB-CP=PERF-MDST
 ‘Oh, [our] father **has come (I just realise)**.’
- Some Kenhat speakers use the normal, that is, dialect-specific GEM for both the wrong assumption and the surprise realisation, the only difference then being the emphatic intonation for the latter. This will be marked here with an initial inverted exclamation mark. However, for some of them, the mirative distance marker *-suk/-sok* may nevertheless appear in the specific context of recognising oneself on a photograph or identifying a surprise guest. The mirative distance marker then indicates that some reasoning is involved, and that the realisation is somewhat delayed (cf. the difference between *inmaŋ* and *intsuk* in the Baltipa dialect of Turtuk, example (25), p. 42).
- (49) Liktsapa (Kenhat, Upper Indus dialects, field data 2018)
ŋ·e-ne sam khjoraŋ lugzi j̄inak sam, t̄itear j̄inak!
 I+ERG-TOP think=PA fam.you shepherd be=GEM think=PA teacher be=GEM
 ‘I thought you were a shepherd, [but] (**against my expectation**) you **are** a teacher!’
- (50) a. Liktsapa (Kenhat, Upper Indus dialects, field data 2018)
o ŋ·e-ne i·(:)zuŋa ho-kan-de no j̄inak sam.
 intj I+ERG-TOP this·PPOS exist-NLS-DF younger.brother be=GEM think=PA
m̄an-tsuk, ŋaraŋ j̄in-tsuk.
 NG.be-MDST I.self be-MDST

‘Oh, I thought the one in the middle [of the photograph] was [my] younger brother. [But] it **isn’t** him, **it’s** me!’ (**Sudden, possibly delayed realisation**: the speaker had misidentified himself.)

b. Likksepa (Kenhat, Upper Indus dialects, field data 2018)

i+(:)zuna ho-kan-de no manak-pa, naray jinak.
 this+PPOS exist-NLS-DF younger.brother NG.be=GEM-emp I.self be=GEM

‘The one in the middle [of the photograph] is not my brother (as you said); it is me (as you might want to know).’ (**Explanatory mood**: somebody else had misidentified the person on the photograph.)

Both, the mirative distance marker and the GEM, may be used upon recognising (or thinking that one recognised) a surprise guest. However, when the surprise guest has been misidentified, s/he will not use any of these markers but only the plain copula for the contradiction:

(51) Likksepa (Kenhat, Upper Indus dialects, field data 2018)

au rinteen jin-tsuk-pa! / jjinak-pa! –
 uncle(FB) Rincen be-MDST-emp be=GEM-emp

man na au rinteen man,
 NG.be.ASS I uncle(FB) Rincen NG.be.ASS

au dordze jin, ft zer-hak?!
 uncle Dorje be.ASS what say-DST

‘[Oh] you are uncle (i.e., father’s brother) Rincen (as I recognise / **can see**)! – No, I am not uncle Rincen, I am uncle Dorje, what are you saying?!’ (The mirative distance marker indicates a **becoming aware** involving some process of thinking. / The GEM indicates a more immediate or **direct recognition**. There is no connotation of doubt.)

A comparable usage for unexpected identifications based on sense perception has been described for the dialect of Lende, Kyirong in southern Tibet. Huber (2005: 99, 101) describes the compound form *jimbe*: as an equative copula indicating new knowledge through immediate sensory access or inference.

(52) Dialect of Lende (Kyirong, Western Central Tibetan, Huber 2005: 101, ex. 66)

di tea: jimbe.

this tea COPULA.SENSORY

‘This is tea.’ (**Visual inference**: “This sentence can be uttered when the speaker had thought that there was water in a certain bottle, but when he pours it into a glass, it **turns out to be** tea.”)

3.1.4 Background identification and/ or shifted epistemic stance in narratives

When telling traditional stories: jokes, fairy tales, the Kesar epic, or also stories about the past, the narrators have a great choice of different distance markers, as well as of the unmarked (past) stem, when they get more involved in the narrated events. Apart from these markers, the GEM may be used, when the identity of some being is revealed. This can be seen either as marking of background information or as a special case of sudden realisation and surprise – on the part of the narrated person (second-hand or shifted epistemic stance). As in the above examples of section 3.1.3, Kenhat speakers may again use the mirative distance marker *-suk/-sok*, contrasting with the normal narrative distance marker(s).

In order to obtain the following data, I usually presented the informants with an episode of the Kesar epic, of which most of them have heard, although not often enough to remember and to be able to tell themselves. Hence, I usually told the episode sentence by sentence, more or less according to the model of (53), and let them translate it, but I also pretended to be a real audience, interacting with the obligatory comment ‘yes it is’, in order to create an atmosphere of narrative performance, which would ease the remembering of the particular narrative distance markers. That the speakers may then select different markers, depending on the narrative mood, is shown in the example from the Çarapa speaker, (56). The Gya-Mirupa speaker came up with her own version, where an episode from a later part of the epic got integrated, (57).

In the episode at hand, from the beginning of the epic, a white and a black yak are fighting, and when the black yak is about to win, a human observer decides to kill the black yak. It then turns out that the white yak is the god of the heavens, Indra, and the black yak is a demon. In order to show the usage of different narrative constructions, I shall include also one line from the main story line in the following examples, as far as such different forms are used.

- (53) *Lower Ladakhi Version of the Kesar Epos* (Khalatsepa, Shamskat, Western Shamma, Francke 1905–41: 32)
- kho+s dbyug.rdo btañ-ste g,yag nag.po de ši-soñ |*
s/he+ERG sling give-LB yak black that die-go.PA
g,yag nag.po de bdud cu.ru.lu.gu yin.tshug |
yak black that demon Curulugu be=GEM
g,yag dkar.po de lha·hi dbañ.po rgyab.bžin yin.tshug
yak white that god·GEN Mighty Indra be=GEM
‘He applied [his] sling and the black yak was stone-dead. The black yak **was (actually)/ turned out to be** the demon Curulugu. The white yak **was (actually)/ turned out to be** Mighty Indra from the gods.’⁶⁶
- (54) Tyaksi-Thangpa (Eastern Baltipa, field data 2022, *Kesar*, elicited)
- dena apo-si nakpo hjak-po-la da tañ-se-na-džukpa(:) sat-paintsuk lo džu.*
then grandfather-ERG black yak-DF-ALL arrow send-LB-ABL-after kill-PA.DIST QOM intj
nakpo hjak-po dre-fetantsok in-suk džu.
black yak-DF demon-devil.like be-INF/DST intj
karmo hjak-po mala ljaçmo in-suk. fariftatsok in-tsuk džu.
white yak-DF very good be-INF/DST angel.like be-INF/DST intj
‘The grandfather then shot an arrow and killed the black yak, [they] say, yes. The black yak **was (actually)/ turned out to be** a kind of demon or devil. The white yak **was (actually)/ turned out to be** very good, a kind of angel.’

⁶⁶ The spelling *tshug* is a writing convention, not based on any articulation reality. In this version, the inferential-*cum*-distance marker “tshug” also appears whenever something funny or unconventional happens. In such cases, the epistemic shift may concern the implied bystanders, but the inferential-*cum*-distance marker also seems to be used as a strategy to draw the attention of the audience to a crucial point, and thus to involve the audience more, according to its mirative function. For details see Zeisler (2004: 810–814).

- (55) Shachukulpa (Kenhat, Lalokpa, field data 2016, *Kesar*, elicited)
tene mē-e jūgdo tāŋ-de jāk nākpo-re sa:t. – endžu! –
 then grandfather-ERG sling give-LB yak black-DF kill=PA intj
jāk nākpo-re dut fūrulugu ħin-tsuk. – endžu! –
 yak black-DF demon Curulugu be-MDST intj
jāk kārpo-re lā wāŋbo gjaṭṭin ħin-tsuk. – endžu! –
 yak white-DF deity mighty Indra be-MDST intj
 ‘Then the grandfather whirled the sling and killed the black yak. – Yes, it was so! – The black yak **was (actually)/ turned out to be** the demon Curulugu. – Yes, it was so! – The white yak **was (actually)/ turned out to be** the deity Mighty Indra. – Yes, it was so! –’
- (56) a. Çarapa (Kenhat, Upper Indus dialects, field data 2016, *Kesar*, elicited, first version)
tene khe jāk nākpo sat-phentsuk.
 then she-ERG yak black kill-PA.DST
denb+enaŋa jāk kārpo gonbo inak.
 true+PPOS yak white protector be=GEM
 ‘Then he killed the black yak. In reality, the white yak **was** the protector deity (Mahākāla).’
- b. Çarapa (Kenhat, Upper Indus dialects, field data 2016, *Kesar*, elicited, second version)
jāk nākpo-a khe da tā-re sat-pintsuk. – endžu! –
 yak black-ALL s/he-ERG arrow give+LB kill-PA.DST intj
khas jāk nākpo dut teūrulugu ħin-tsuk. – endžu! –
 truly yak black demon Curulugu be-MDST intj
jāk kārfo lā-e aŋbo gjaptein ħin-tsuk. – endžu! –
 yak white god-GEN mighty Indra be-MDST intj
 ‘The black yak, he shot an arrow at and killed [him]. – Yes, it was so! – **In reality**, the black yak **was/ turned out to be** the demon Curulugu. – Yes, it was so! – The white yak **was (actually)/ turned out to be** Mighty Indra from the gods. – Yes, it was so! –’
- (57) Gya-Mirupa (Kenhat, Upper Indus dialects, 2017), *Kesar* (free narration)
tene mēme kjōnfan-e «ŋa:(.) dzayoraŋ zukfo ifhenmo so+re
 then grandfather cunning-ERG I+AES friend.self illness great go.PA+LB
ŋa:(.) thak-ṭe-me-rak» zer-de,
 I+AES be.able.to.hold.up-GRD-NG-NVIS=PRS say-LB
jāk ſi-ṭfuk, / ſi-ṭfuk-(k)antsuk, džu. – endžu –
 yak die-let=PA die-let-PA.DST intj intj
dend+enaŋa jāk kārfo-re lā wāŋbo gjaṭṭin ħin-tsuk, džu.
 truth+PPOS yak white-DF god mighty Indra be-MDST intj
jāk nākpo-re dut kjūrulugu ħin-tsuk, džu.
 yak black-DF demon Kyurulugu be-MDST intj
 ‘[After the black yak had been blinded and tricked into a pit], ‘then the cunning old man said: «My friend, I got seriously ill, I am not able to push you up (lit. hold you up)», and let the yak die, yes. – Yes, it was so! – **In reality**, the white yak **was/ turned out to be** the god Mighty Indra, yes. The black yak **was (actually)/ turned out to be** the demon Kyurulugu (the Skinny Lamb), yes. »’

The mirative distance marker may also appear in historical narratives, at least in the Lehpa dialect. At the end of her book, Koshal (1979) gives a version of the biography of the historical

person Rincen Zangpo. At some point, Rincen Zangpo meets an important person, who then gives some particular predictions about him. Then the identity of that person is specified:

- (58) Lehpa (Kenhat, Central Ladakhi), *Rincen Zangpo* (Koshal 1979: 323–324, adapted)
teru khon sot snoms-la pheps-pasaj tamze rgatpo-zik-taj dzal ...
 there hon.s/he hon.alms hon.beg-ALL hon.go-NLSA Brahmin old-LQ-COM hon.meet=PA
khon-ni tamze tatfhat-gofha zu-kan in-tsuk.
 hon.s/he-TOP Brahmin Tatchat-Gocha hum.ask-NLS be-MDST
 ‘When he [Rincen Zangpo] went there for begging alms, [he] met with an old Brahmin.
 ... That one **was/ turned out to be** the Brahmin called Tatchat Gocha.’

Although this usage appears to be a narrative convention, neither the GEM nor the mirative distance marker are obligatory in this context. Other speakers may use the narrative distance markers of the main story line also for this kind of identification, continuing the narrative stance that this is only a story.

- (59) Ciktanpa (Shamskat, Eastern Purikpa, field data 2016, *Kesar*, elicited)
nakpo jak-po but in-mintsuk.
 black yak-DF demon be-PA.DST
karpō jak-po pari in-mintsuk.
 white yak-DF fairy be-PA.DST
 ‘The black yak was a demon; the white yak was a fairy.’
- (60) Lingshetpa (Shamskat, Southern Shamma, field data 2016, *Kesar*, elicited)
deana meme-s jak nakpo-a da taj-se sat-kanok. – enju –
 then grandfather-ERG yak black-ALL arrow give-LB kill-DST intj
jak karpō la wanpo gjaŋin in-kak. – enju –
 yak white deity mighty Indra be-DST intj
jak nakpo rdut-ŋik in-kanok. – enju –
 yak black demon-LQ be-DST intj
kho-s jul-iffia phantoks ma-ŋos-kanok.
 s/he-ERG land-PPOS benefit NG-do.PA-DST
 ‘Then the grandfather shot an arrow at the black yak and killed him. – Yes, it was so. – The white yak was the deity Mighty Indra. – Yes, it was so. – The black yak was a demon. – Yes, it was so. – He had not done anything good for the land.’

Given this contrast, it seems that in such contexts, the combination *intsuk* may have the function to point at specific background information, and that this information is directed to the audience by the narrator. This became apparent to me when I looked at one of the last remaining historical manuscripts from Shigar in Baltistan, written in quite a peculiar script⁶⁷ (Schuler 1978).

⁶⁷ The script is a curious mixture of Indic and Persian features. Although no similar scripts seem to be documented, it might be quite a distant descendant of the Gupta script, possibly an independent variant of the Laṇḍa group (one can see few similarities with the Multanī script and even fewer with Gurmukhī). Like all Indian scripts, it is written from left to right. Like in all Indian scripts, aspirated consonants have their own character. The characters do not combine, but with their headlines, they could form a continuous line. However, in many other aspects, the script follows the principles of the Persian script. Like in the Persian script, the retroflex letters *t*, *d*, and *r* are derived from their non-retroflex counterpart. In correspondence to the Persian script, there are only two characters for nasals: *n* and *m*. A diacritic sign may appear infrequently on the *n* for /ŋ/. In one case, this combination is followed by *g*. A special

In that text, *insuk* appears infrequently instead of the plain copula, and the only reason that I can recognise seems to be a somewhat more detailed or more specific background information. Compare the first sentence of example (61), which talks about the identity of the first settlers in general terms as being from Central Asia with the plain copula, with the last two sentences of that example, which both identify the members of a ruling lineage. In these two sentences, *insuk* is used. It is quite clear that in this context *insuk* does not indicate an inference or a coming to know. Neither can it indicate lesser certainty. If there is any hedging intended, then the choice of *insuk* instead of the plain copula might indicate that the writer modestly wants to downgrade his expertise, perhaps to indicate that he talks about a lineage to which he and his family do not belong. This kind of pragmatic hedging might be less necessary when talking in a broad manner and about a fact (or hypothesis or illusion) the speaker identifies with.

In combination with *jot*, on the other hand, *-suk* appears to have the function of a past tense marker, whether *jot* is used as auxiliary or as existential linking verb. No other epistemic or evidential marker appears in the text, which deals with facts the writer has not seen himself, but only knows from tradition or from other documents. The whole text shows a ‘factual’ attitude. Even when the writer mentions that there is a certain talk by the people, which may indicate some hedging, no particular epistemic or evidential markers are used, cf. the second part of (61). Since I cannot decide the exact function of *-suk* in the Baltipa dialect of Shigar, I shall mark it merely as EVALUATIVE MARKER (EM).

The transliteration given by Schuler takes some getting used to, as it partly follows conventions for Iranian scripts; however, it is inconsistent in many ways.⁶⁸ Based on the just mentioned conventions, I shall use here a radical transliteration, indicating the full letters *alif*, *vau*, and *ye* with capital letters A, W, and Y, and the corresponding diacritic letters *zabar*, *peś*, and *zer* with small a, w, and y. This transliteration allows representing the quite interesting written vowel combinations. Crossed-out letters will be presented as such; if not readable, I shall use a crossed-out capital x. This transliteration will be given in each second line in a differing and smaller font. In the third line, I shall give a phonological rendering as could be expected for a Baltipa dialect. I suppose that also the name element *khanj* in the later part should have been *khan*, particularly since the writer did not feel any need to mark any of these finals with a diacritic sign, but, of course, this is no proof.

character or diacritic for /ɲ/ is missing; this phoneme is rendered as cluster *ny*. Only one character is used for Baltipa /z/ and /dʒ/, the latter only marginally attested in the Baltipa dialects. In Schuler (1978) it is associated with the letter *jīm*. It will be transliterated accordingly as *j*. An additional character is used indiscriminately for *ts* and *tsh*. Two further characters are added for Arabic/ Urdu *khaḥ* and *ghain*. The vowels and semivowels *i/e/y* and *u/o/v* are not discriminated, and unlike in Indian scripts, but according to the Persian script, the diacritic sign *zer* for the vowels *i/e* is below the consonant, and the diacritic sign *pesh* for the vowels *u/o* is above the consonants. Initial vowels are based on *alif*. Vowel *a* is always to be indicated, although the text shows some omissions, which in part may also be due to the bleaching of the ink. Some vowel signs are misplaced and set off to the right. Some tricks are used inconsistently to discriminate between *e* and *i* and between *o* and *u*. Words and very often also grammatical elements are separated by spaces. However, some of these spaces may not always have been intended as word spaces.

⁶⁸ She differentiates between long and short vowels, interpreting the former as *a*, *e*, *i*, *o*, *u*, but not the latter, which she gives as *ə*, *y*, and *w*. There is no phonemic length distinction in Balti, that is, vowels in open syllables are slightly longer than in closed ones, but Schuler renders also vowels in closed syllables as long ones. She consistently does not differentiate between non-aspirated *c* /tʃ/ and aspirated *ch* /tʃh/, despite there being two different characters. Likewise, she does not discriminate between non-aspirated *ts* and aspirated *tsh*. In both cases, she only gives the non-aspirated version, despite the fact that the third character is defined as “tsh ʃ”⁷. Schuler is clearly not a linguist, and her non-identification of several nasal velars in trivial words indicates that she did not know (much) Balti at that time. Most likely, she got the text read out. Some words and passages are missing.

དཀ་མ་ མེ་ལྷ་ ལོ་ལྷ་ལྷ་ལྷ་ ལྷ་ལྷ་ལྷ་ ལྷ་ལྷ་ ལྷ་ལྷ་ ལྷ་ལྷ་ ལྷ་ལྷ་
 daYkha myY Ywdpazyrb chahrTx syn cwgyw kWad cy cyk
dekha mi jot-pa zer-b+i fhartaxs-in fshovo kuat fifik
 there person exist-NLS say-NLS+GEN sign/token-LOC big pot single
 ལྷ་ལྷ་ ལྷ་ལྷ་ ལྷ་ལྷ་ ལྷ་ལྷ་ ལྷ་ལྷ་ ལྷ་ལྷ་ ལྷ་ལྷ་ ལྷ་ལྷ་
 gywry baryn thalba gansy daxsan thwnyman Ywd
korw-ebariñ thalba garñ-se daxsan(g) thoneman jot.
 stone-PPOS dust fill-LB right.now until exist
 ‘As a sign of the people who are said to have lived there, there is until now among the
 stones one big pot filled with dust/ earth.’

དཀ་ མེ་ལྷ་ ལྷ་ལྷ་ ལྷ་ལྷ་ ལྷ་ལྷ་ ལྷ་ལྷ་ ལྷ་ལྷ་ ལྷ་ལྷ་
 daY myYtshyr jwkpw khan zaXrkhan kwn Any swk.
de mitshir dzukpo khan/ñ zer-khan-kun in-suk.
 that person.row end Khan(g) say-NLS-PL be-EM
 ‘The last of that lineage **are/ were** those called «Khan(g)».’

ལྷ་ལྷ་ ལྷ་ལྷ་ ལྷ་ལྷ་ ལྷ་ལྷ་ ལྷ་ལྷ་ ལྷ་ལྷ་ ལྷ་ལྷ་ ལྷ་ལྷ་
 gYa khn gYapa khn tYastYcw Ywktham Ywkamathm a
gjakhan/ñ gjapakhan/ñ testetfo joktham jokmatham
 Gyakhan(g) Gyapakhan(g) Testeco Yoktham Yokmatham
 ལྷ་ལྷ་ ལྷ་ལྷ་ ལྷ་ལྷ་ ལྷ་ལྷ་ ལྷ་ལྷ་ ལྷ་ལྷ་ ལྷ་ལྷ་ ལྷ་ལྷ་
 šarkhan markhan cakhan capa khan
farkhan/ñ, markhan/ñ, fjakhan/ñ, fjakpakhan/ñ,
 Sherkhan(g) Markhan(g) Cakhan(g) Capakhan(g)

ལྷ་ལྷ་ ལྷ་ལྷ་ ལྷ་ལྷ་ ལྷ་ལྷ་ ལྷ་ལྷ་ ལྷ་ལྷ་ ལྷ་ལྷ་ ལྷ་ལྷ་
 khWwYy bwWn šYrb tan na mashaYd khwñy cwsyr⁷² Ayn swk.
khw+e bu+n serbuñan-na mašaid khoñ-i fotshir in-suk.
 he-GEN son+PL Sherbuñan-COM Mashaid they-GEN ruler.row be-EM
 ‘Gyakhan(g), Gyapakhan(g), Testeco, Yoktham, Yokmatham, Sharkhan(g), Markhan(g),
 Cakhan(g), Capakhan(g), [and] his sons Sherbuñan⁷³ and Mashaid **are/ were** their successors
 as rulers.’

If my interpretation of *insuk* in this Baltipa text is correct, then we no longer deal with an epistemic function of the combination *yin* plus *sug*, but with the broader ‘factual’ function of the GEM, concerning explanations and shared knowledge, to be discussed in section 3.4.

Nevertheless, in narrations, the moment of identification may be interpreted also as the sudden realisation of an unexpected fact by the narrated figure, that is, as a case of shifted epistemic stance. This holds at least for the subsequent examples from Southern Purikpa and Eastern Baltipa. According to this interpretation, the informant from Sankoo stated that a narrator may switch between his or her own knowledge and that of the person narrated; and in the latter case the use of *sug* indicates the immediate coming to know of the narrated third person, while the use of the

⁷² This is quite apparently a slip of the pen; elsewhere, the word is given as *cwtslyr*.

⁷³ The name is given as “Shiribuñan” by Schuler, but it might have been Šer-e b[h]uñān “Lion of the Baltis” or, less likely, Šer-e butān “Lion of the demons”.

past distance marker indicates a coming to know after some time, either of the narrated third person or of the narrator him-/herself. In order to demonstrate this, I suggested translating a partly invented historical account. That is, the first three lines refer to the historical situation; the rest was invented to obtain the corresponding forms for the particular context.

- (62) Sankooa (Southern Purikpa, field data 2022), *Kartse Chamba*, suggested translation
- | | | | | | | |
|-------------------|--------------------|------------------------------|-----------------------|------------------------|--------------------------|-------------------|
| <i>kartse-a</i> | <i>rgjapu-ik</i> | <i>jot-pin.</i> | <i>kho</i> | <i>bot</i> | <i>in-min.</i> | |
| Kartse-ALL | king-LQ | exist.ASS-RM | s/he | Buddhist | be.ASS-RM | |
| <i>kho-s</i> | <i>mi-saḅ-a</i> | <i>khunti</i> | <i>bot-i</i> | <i>ḡhos</i> | <i>ḡtsab-imiḡna</i> | |
| s/he-ERG | people-PL-ALL | they.GEN | Buddhist-GEN | religion | teach-PPOS | |
| <i>rdoa-ḡfika</i> | <i>sku-ik</i> | <i>ḡfo-ḡfuks-pin.</i> | | | | |
| rock-LQ.PPOS | statue-LQ | construct-cause.PA-RM=ASS.PA | | | | |
| <i>sku</i> | <i>ḡfo-khan-po</i> | <i>rgjala</i> | <i>ses-khan</i> | <i>tsal-e</i> | <i>lamajuru-a</i> | <i>soḡ-min.</i> |
| statue | construct-NLS-DF | good | know-NLS | search-LB | Lamayuru-ALL | go.PA-RM=ASS.PA |
| <i>deka</i> | <i>lamajur-i</i> | <i>lama</i> | <i>ḡhoko-naḡnambo</i> | <i>thuk-se</i> | <i>spera</i> | <i>tans-pin.</i> |
| there | Lamayuru+GEN | lama | great-PPOS:COM | meet-LB | talk | give.PA-RM=ASS.PA |
| <i>lam-e</i> | <i>miḡ-a</i> | <i>sketpa</i> | <i>rinpoche</i> | <i>zer-en-jot-suk.</i> | <i>zer-bat-pin.</i> | / |
| lama+GEN | name-ALL | Sketpa | rinpoche | say-CNT-EX-INF/DST | say-NLS.EX-RM=ASS.PA.HAB | |
| <i>de</i> | <i>lama</i> | <i>sketpa</i> | <i>rinpoche</i> | <i>in-mintsuk.</i> | <i>in-min.</i> | / |
| that | lama | Sketpa | rinpoche | be-PA.DST | be.ASS-RM | |
- ‘In Kartse, there was a king. He was a Buddhist. In order to bring all people closer to their Buddhist religion (lit. in order to teach), he arranged that a statue was carved out of (lit. made on) the rock. Searching for an expert in making [such] statues, he went to Lamayuru. There he talked with a great lama. The lama **was called** Sketpa rinpoche (**as the king found out** / as I know well). / That lama was the Sketpa rinpoche (as the king or I found out later / as I know well).’

Since this is supposed to be a historical narration, the speaker chose the assertive past (stem II+NLS+yin) both for the main story line and for presenting the information about the rinpoche from the historian’s perspective as someone who has certain knowledge. However, the inferential-cum-distance marker is used when the narrator wants to shift the epistemic stance of just finding out upon the narrated person. The past distance marker can be likewise used to shift the epistemic stance upon the narrated person, but it may also be used if the narrator wants to signal that s/he came to know about the fact much later than about the history itself.

In a similar manner, the combination of yin and sug is used by the Tyaksipa speaker as an auxiliary in a historical narrative about the tragedy of Karbalah whenever a narrated third person comes to know something. In one case, followers of Husseyn, who are visiting the graves on the battlefield, see dust rising at the horizon and a large party coming closer. At first, they prepare to fight the enemy, but upon seeing a black flag, they realise that the survivors of the battle are coming back from the opponent’s court. In another case, Husseyn’s little daughter, who had been left back when Husseyn left for Kūfah, and who was not aware about what happened thereafter, comes to know that the family is returning and runs off to meet them all, not knowing that her father and her beloved brothers are no longer alive. Similar to the artificial historical account from Sankoo, the combination of the copula with sug stands in sharp contrast to the use of the unmarked and perhaps ‘factual’ past tense (mere stem II) and the assertive past (stem II+NLS+yin) used throughout the narrative.

- (63) a. Tyaksipa (Eastern Baltipa, 2022), *Karbalah*
kufik duk-pa, dʒinab-i dʒabir-i kulam-po-la nakpo alamkat thoŋs.
 a.bit stay-NLS venerable-IZF Jabir-GEN servant-DF-ALL black flag see.PA
de alamkat thoŋ-ma-na, khõ-la ŋozin soŋs :
 that flag see-NLS-ABL they-ALL knowledge go.PA
imā:m husein-i qafilá karbalá-irolla õ-en-in-tsuk.
 Imām Husseyn-GEN caravan Karbalah-PPOS come-CNT-CP-INF/DST
 ‘Staying [so] for a while, the servant of venerable Jābir saw a black flag. Upon seeing that flag, they came to know that [it was] the caravan of Imām Husseyn [that] **was coming** towards Karbalah.’
- b. Tyaksipa (Eastern Baltipa, 2022), *Karbalah*
imā:m husein-i fjak-po karbalá-iaŋ faχ-f-e waχ-p·eanu
 Imām Husseyn-GEN hon.presence-DF Karbalah-PPOS hon.go-NLS-GEN time-DF+PPOS
tsuntse boŋo ffig-la madin·eaŋ skjur-e sō-fa-in-pa.
 smallest girl single-FM Mādinah+PPOS abandon-LB go.PA-NLS-CP-RM=ASS.PA.PERF
mo-i miŋ-po-la fatima zogra in-pa.
 she-GEN name-DF-ALL Fātimah little be.ASS-RM
namisaŋ rgjalmo zeinap-na ã-o striŋmo gaŋma
 when lady Zaynab-COM mother-DF sister all
madin·eaŋ lok-se thon-p·idʒukpa(:)
 Mādinah+PPOS return-LB arrive-NLS+PPOS
fatima zogra-la ŋozin soŋs :
 Fātimah little-ALL knowledge go.PA
ŋ·i bawa-dun lok-se madin·eaŋ thon-pa-in-tsuk, zer-e-na,
 I+GEN father-with.all return-LB Mādinah+PPOS arrive-NLS-CP=PERF-INF/DST say-LB-ABL
tsal-en-ŋfi qafilá-i zeinab-irolla õs.
 search-CNT-LQ caravan-IZF Zaynab-PPOS come.PA
 ‘At the time when the honourable Imām Husseyn set off for Karbalah, he had left [his] smallest daughter behind. Her name was Fātimah, the Little. When lady Zaynab together with all the women (lit. the mother and sisters) arrived at Mādinah, Fātimah, the Little came to know: my father and all **have arrived** back at Mādinah, and saying so, [she] came towards the caravan of Zaynab in search [for him].’

A nice example is also found in the story of Prince Čobzaň (Bielmeier 1985: 36, sequences 13,19-13,25). The hero of the story, who has obtained a fairy as his wife and lives in her palace, enters a forbidden room with many windows, and when looking through each of the windows he sees a different scene, associated with the four seasons. The observed activities are all described with the construction *V-et-suk*. The epistemic shift concerns the narrated figure’s visual perceptions as well as his surprise (at the last window he sees his impoverished home country and his deserted first wife, and accordingly, he develops homesickness).

Similar examples of epistemic shift with or without a connotation of surprise are also found in the Kesar Epic from Khalatse (Francke 1905–41) and in the Ciktan version of the epic (Herrmann no date), in both cases with the related form *V-at-suk*. In Zeisler (2004: 814– 829), I described such usages as narrative conventions of looking into an (ongoing) scene and of coming onto the (already ongoing) scene. In both cases, the narrated third person observer(s) is/ are made explicit.

In my opinion, the above-described two functions of *sug* as an epistemic marker of preliminary realisation or unexpected perception and as a marker of background knowledge may not be contradictory, but rather seem to be related. That is, the possibly more original function as marker of preliminary or non-confirmative realisation may have been conventionalised in order to signal background information. The use of *sug* for a shifted or second-hand epistemic stance could be likewise seen as a conventionalised extension. However there is evidence that before ‘evidentiality’ was conventionalised and grammaticalised in the modern Tibetan languages, the admirative marker *hdug*, indicating non-confirmative knowledge, such as assumptions and first perceptions, was freely used for first perceptions and misperceptions of narrated third persons (Zeisler 2018a: 117f.). It seems thus that the Baltipa, Purikpa, and Western Shamma inferential-*cum*-distance marker and the Kenhat mirative distance marker *sug* have preserved this original function of indicating a shifted or second-hand epistemic stance.

3.1.5 Assumptions about future situations

The prospective construction (V-GRD-Aux) with the GEM has both assumptive and merely imaginative, that is, irrealis functions (for the latter see sections 3.2.2 and 3.2.4). According to the epistemic sub-function of *inok* & siblings, the construction can serve to imagine or assume future situations of great likelihood, without being fully certain, examples (64) to (66). The construction stands in concurrence to various other assumptive or probability constructions. They are given as alternatives indicating different grades of likelihood in examples (67) and (68).

- (64) Mulbekpa (Shamskat, Eastern Purikpa, field data 2016)
askj-a khimtsesp-i nono-s khuri rta-o tsoŋ-ŋa-intsuk.
 tomorrow·ALL neighbour·GEN younger.brother-ERG s/he.self.GEN horse-DF sell-GRD-GEM
 ‘Tomorrow, the neighbours’ younger brother/ son **is apparently going to sell** his horse.’
 (The speaker has some kind of indirect input; the other person had talked vaguely about that he wants to sell the horse.)
- (65) Tagmacikpa (Shamskat, Western Shamma, field data 2019)
kho rkunma intsok, jeraŋ fiŋtoŋ-ŋik dzat!
 s/he thief be=GEM hon.you something-LQ hon.do=IMP
men-na jaŋ rku-ŋa-intsok, jirikana rku-ŋa-intsok.
 NG.be-CD again steal-GRD-GEM hon.you.PPOS:ABL steal-GRD-GEM
 S/he is a thief; you should do something! Otherwise [s/he]’ll **steal** again; [s/he] **might** [even] **steal** from you.’ (Talking to the village head in a meeting. [The speaker cannot know for certain that another theft will occur.])
- (66) Lingshetpa (Shamskat, Southern Shamma, field data 2016)
kho-a snambu maŋbo jot-sok.
 s/he-AES snambu many have-INF/DST
di snambu tshaŋma tšoŋ-na, pene maŋbo thop-ŋa-nok.
 this snambu all sell-CD money much get-GRD·GEM
 ‘S/he must have many *snambu* (traditional woollen cloth). If [s/he] sells all these *snambu*, then [s/he]’ll **get/ quite likely** [s/he]’ll **get** a lot of money.’

The first sentence of (66) contains a contextually given inference based on sense perception: according to the explanation of the informant, one might have seen that these people have many

sheep; one can thus conclude that they *must have* a lot of wool, and hence they *must have* a lot of *snambu*. Based on this reasoning, the second sentence contains a predictive inference through further reasoning concerning a future situation.

(67) Gya-Mirupa (Kenhat, Upper Indus dialects, field data 2019)

kīn-e kīnra-ne kīnṭuk bor-de-duk;
 ibex-GEN ibex.enclosure-ABL/LOC ibex.child keep-LB-VIS=PERF
kīn-e ama lok-te-ḥoṅ-tfe-inak. / lok-te-ḥoṅ-at-to. /
 ibex-GEN mother return-LB-come-GRD-GEM return-LB-come-EX-PRB
lok-te-ḥoṅ-ar-aṅ, tḥi pata. / lok-te-ḥoṅ-tfe-duk.
 return-LB-come-EX-PRB what knowledge return-LB-come-GRD-VIS=PROSP

‘On the [protected] place where the ibex use to stay, an ibex kid is kept behind; the ibex mother **will likely come back** (sometime later). / will probably come back (soon). / might come back, but [who] knows. / is about to come back (as I can see).’ (The gerundive construction with the GEM is used when the ibex mother is not in view and thus expected to return only some time later. The speaker **imagines** the situation. / The probability marker *-to~-do* is used for a situation expected to happen more immediately, and here, it implies that the ibex mother is near by. / The probability marker *-aṅ* usually indicates that the speaker is less certain, which may often be emphasised by an expression of strong hedging: ‘who knows’. Here, it indicates that the ibex mother is merely expected to return soon. / The prospective construction with the visual marker indicates that the assumption is based on some visual input.)

(68) Faḍumpa (Kenhat, Central Zanskarpa, field data 2019)

tundub-e khorā-a buk tshayma lāh-eka ḍemo tḥø-ḍe ri²-du²,
 Tundup-ERG s/he.self-GEN book all shelf+PPOS nice do-LB arrange-VIS=PRS
te kh-øe nama lamo-ñampo thop-tfe-no². /
 then s/he-GEN wife easy-PPOS:COM find-GRD+GEM
thob-e-no². / thob-en.
 find-NLS+GEM=DPG find-CP=ASS.FUT

‘Tundup is arranging his books on the shelf, so that his wife **may / will easily find** [whichever she needs].’ (The gerundive construction with the GEM is used for an **assumption** when one is **not fully sure** about the result. / The DPG indicates that the speaker is sure. / The assertive future similarly indicates the speaker’s certainty, but it has a more subjective connotation of giving one’s own opinion, especially when giving advise to the addressee or when showing one’s experience, approving or also criticising the activity.)

The epistemic non-confirmative value of assumptions may be exploited for a socio-pragmatic value of lowered epistemic authority, as when making suggestions (see also section 3.2.4) or also when explaining a situation. In the following example, the gerundive construction may not only express an inference, but also an explanation or background information, focusing thus more on the addressee than on one’s own access to knowledge:

(69) Tagmacikpa (Shamskat, Western Shamma, field data 2019)

lama-s derij skurim tfo-tfa-intsok.

lama-ERG today ritual do-GRD-GEM

‘The *lamas* **are apparently going** to perform the (household) ritual (I **infer** this: because I have seen them going to my house/ because I have seen my parents prepare for their visit).’

Or:

‘(You **know**,) the *lamas* are going to perform the (household) ritual (**this is why** I can’t come today).’

3.2 *Irrealis contexts*

The use of the Shamskat GEM *intsok* in merely imaginative or irrealis contexts may readily be explained by the non-confirmative value of the inferential-*cum*-distance marker *-suk/-sok*. The latter marker may also appear with constructions containing the existential auxiliary *jot*; and it appears in the Kenhat dialects as a specialised mirative distance marker (MDST). However, in the case of the compound form *intsok*, this irrealis and mirative function can no longer be separated from all other functions. Note also that in the Lingshetpa dialect, the irrealis function is associated with the GEM *inok*, see examples (74) and (83). Even individual speakers of the Kenhat dialects may make use of the GEM in imaginative situations, see example (84) from the Çarapa dialect. It is possible, though, that this usage reflects some influence from the Western Shamma dialects.

3.2.1 *Conditioned assumptions about the future*

The assumptions described in section 3.1.5 are based on observed facts. The GEM as copula may infrequently also be used instead of the prospective gerundive construction for future situations that depend on the realisation of a particular condition in the present or future. In the Tagmacikpa dialect, the projected result is seen as possible only when the condition holds, which may or may not be the case. In the Gya-Mirupa dialect, by contrast, the speaker is convinced that the condition or precondition will hold. Similarly, when used in negation, the speaker is convinced that the (pre-) condition does not hold. In cases of uncertainty or doubt, other constructions must be used.

(70) Tagmacikpa (Shamskat, Western Shamma, field data 2022)

galtes kho pas tpha-na-ni kho koleđpa gjur-tfa-intsok. / intsok.

if(f) s/he pass go-CD-emp she college.student become-GRD-GEM be=GEM

inaŋ kho-s gjala ma-sil-basaŋ, kho pas tpha-tfa-in-tfa-mi-nuk. /

but s/he-ERG well NG-study-NLSA s/he pass go-GRD-CP=PROSP-GRD-NG-VIS=PROSP

inaŋ kho-s egzam tfikfik ma-taŋs; defia pas tpha-tfa-mentsok.

but s/he-ERG exam single NG-give.PA therefore pass go-GRD-NG.GEM

‘If and only if s/he passes the exam, s/he will become / **will be** a college student. But since s/he did not study well, s/he is not very likely to pass. / But s/he has not taken a single exam (yet); therefore, s/he won’t pass (this will definitely not happen).’

(71) a. Gya-Mirupa (Kenhat, Upper Indus dialects, field data 2022)

i kālat thon-de-tijne kho kōleđpa hinak. / gjur-fe-inak.

this class finish-LB-after s/he college.student be=GEM become-GRD-GEM

‘After finishing this class s/he **will be** / will become a college student. (The speaker is quite sure that the precondition holds, otherwise the future inferential *hin-ka(na)k* would be used.)’

b. Gya-Mirupa (Kenhat, Upper Indus dialects, field data 2022)

i egzam thon-na, kho kōledz-la ħinak.

this exam finish-CD s/he college-ALL be=GEM

‘When s/he finishes this exam [successfully], s/he **will be** [admitted] in college.’

3.2.2 Imagined situations: children’s play roles and stage directions

There are two contexts for the use of *inok* & siblings in purely imagined situations: children’s play roles, as well as stage directions in drama groups,⁷⁴ and explanations. Not all of the informants had played role games and of those who did, not all would use the GEM. For the role assignment, also the plain copula (alternatively also commands) and the copula plus a distance marker have been observed.

When a speaker may use both the plain copula and the GEM or a (mirative) distance marker, the plain copula indicates that the speaker alone decides about the roles, whereas the GEM or the distance marker possibly opens up an opportunity for negotiation. Note also the combination of the GEM with the gerundive construction in (72) and (73), alternative c. for an instruction or plan about how to act, which will be described in section 3.2.4.

(72) Sumurpa (Shamskat, Ldumrapa, field data 2016)

khjoraŋ đam-eaŋ gjapo ħintsuk.

fam.you drama·PPOS king be=GEM

khjorã-se di-di-sak ffo-fa-ħintsuk. / ffo-et-suk.

fam.you-ERG this-this-PL do-GRD-GEM do-EX-INF/DST

‘You’ll be the king in the drama. You should do/ You’ll do this and that.’ (The combination of the gerundive construction with the GEM has a more instructive value. / The combination of the existential with the inferential-*cum*-distance marker has a more descriptive value).

(73) a. Tagmacikpa (Shamskat, Western Shamma, field data 2019)

ŋa aba in, kheraŋ ama in, jaŋ kho phrugu in.

I father be.ASS fam.you mother be.ASS again s/he child be.ASS

‘I am the father, you are the mother, and s/he is the child.’ (The speaker alone decides about who is taking which role.)

b. Tagmacikpa (Shamskat, Western Shamma, field data 2019)

ŋa aba ħintsok, kheraŋ ama ħintsok, jaŋ kho phrugu ħintsok.

I father be=GEM fam.you mother be=GEM again s/he child be=GEM

‘I’ll be the father, you’ll be the mother, and s/he’ll be the child.’ (The GEM indicates that there is some discussion or further explanation ongoing as in the following alternative c.)

⁷⁴ Drama groups have been introduced only in the past few decades, and it appears that the founder of the initial groups was a Shamskat speaker, so his way of expression might have been taken over by other groups. Most informants never participated in such groups, and thus also did not know how such directions could be formulated. Note, however, also the use of *ħintsok* in the task description *kheraŋ gaid ħintsok* ‘you will be the guide’ uttered by the manager of the trekking company, example (94), alternative b., p. 67.

c. Tagmacikpa (Shamskat, Western Shamma, field data 2019)

ŋa aba intsok, ŋa-s philog-a las ʃo-a:(.) ʃha-ʃa-intsok,
 I father be=GEM I-ERG outside-ALL work do-NLS+ALL go-GRD-GEM
ʃiŋ khjoŋ-ba:(.) ʃha-ʃa-intsok, rama:(.) ʃha-ʃa-intsok.
 wood bring-NLS+ALL go-GRD-GEM goat-ALL go-GRD-GEM
kheraŋ ama intsok, kheraŋ-is kharji skol-ʃa-intsok,
 fam.you mother be=GEM fam.you-ERG food boil-GRD-GEM
khimsa zdu-ʃa-intsok, phrugu sukul-a kher-ʃa-intsok, ...
 sweepings gather-GRD-GEM child school-ALL take.away-GRD-GEM
 ‘I’ll be the father, I’ll go out to do [some] work, [I]’ll collect wood, [I]’ll go with the goats. You’ll be the mother, [you]’ll prepare food, clean up/ sweep [the house], and bring the child(ren) to school, ...’

(74) Lingshetpa (Shamskat, Southern Shamma, field data 2016)

ŋa gjapo inok, ŋa ʃhi:(.)ka dug-et.
 I king be=GEM I throne+PPOS sit-EX=ASS.PRS
kheraŋ jokpo inok, s+eka duk!
 you servant be=GEM ground+PPOS sit=IMP
 ‘I’ll be the king. I’ll sit on the throne. You’ll be the servant. Sit on the ground!’

In the case of play roles, some Kenhat speakers again use the mirative distance marker *-suk/ -sok*. In other dialects, however, the dialect-specific distance marker is used. The choice might perhaps depend not so much on the dialect, but on the individual speaker.

(75) Gya-Mirupa (Kenhat, Upper Indus dialects, field data 2015)

khjoraŋ gjafo ʃin-tsuk. khjoraŋ ʃhi-seha dar+a-hot-suk.
 fam.you king be-MDST fam.you throne-PPOS sit+NLS-EX=PRS-MDST
ŋa lōnpo ʃin-tsuk. s+eha dar+a-hot-suk.
 I minister be-MDST ground+PPOS sit+NLS-EX=PRS-MDST
 ‘You’ll be the king. You’ll sit on the throne. I’ll be the minister. [I]’ll sit on the earth.’

I am particularly grateful to Jigmet Yangdol from Gya-Miru for drawing my attention upon this usage, which nicely parallels the French *imparfait préludique*.

A similar use of the *red* and the compound ‘factual’ marker *yin.na.red* is documented for play roles or stage directions for both Standard Spoken Tibetan and the dialect of Mabzhi in Amdo:

(76) Standard Spoken Tibetan (Hongladarom 1993: 1154, ex. 6, adapted)

ŋa ama-la: re: khjēraŋ phumo jinta
 I mother-hon be.DISJUNCT you daughter be.CONJUNCT.IMPERATIVE (ADHORTATIVE)
 ‘I’ll be the mother and you’ll be the daughter.’

It seems that the child wants to swap roles with her mother, given that she adds the honorific marker *-la:*, with which she would address her mother, i.e., *I’ll be you, mother*. When Hongladarom observed this scene and asked the mother why the child would use the ‘disjunct’ or non-egophoric form *red* for herself, the mother “explained that this was because the speaker is not the real mother, but here the child assumes the role of a mother.” In such cases the ‘disjunct’ would be preferred (Hongladarom 1993: 1154f).

- (77) Dialect of Mabzhi (Amdo, East Tibetan, Suzuki & al. 2021: 88, ex. 43, slightly adapted)
kharge lopma jən.nəre.
 he student be.FACTUAL
 ‘He is/ [shall be] a student.’ (“Situation: The speaker is giving a person a role of ‘student’.”)

3.2.3 Imagining exemplary situations in explanations

Example (78) was given spontaneously by the Gyaikpa informant in order to explain the use of the phrase *fiotfedukpen* ‘must have been’. The use of a distance marker for imagined situations in explanations is extremely common, but the GEM can likewise be used, and for some speakers it appears to be obligatory, see example (84). Baltipa speakers of the Turtuk area use the probability marker *(t/n)uk* and the corresponding copula/ existential *duktuk*, (79) and (80).⁷⁵

- (78) Gyaikpa (Kenhat, Upper Indus dialects, 2016), *Linguistic explanation*
pēr-na, ŋa kh·e khimtsepa jin-kak.
 example-CD I s/he+GEN neighbour be-DST
jinan jīt+u me-kak : tē-zane kho tēhukpo fiot-a-met.
 but mind+LOC NG.exist-DST that-when she rich be(X).ASS-QM-NG.be(X).ASS
ŋa·(:) tē-re jīt+u fiot-kak :
 I+AES that-DF mind+LOC exist-DST
kho-a khampa fiot-pen, kho-a galqi fiot-pen.
 s/he-AES house have.ASS-RM s/he-AES car have.ASS-RM
tē·(:)fia kho tē-zane-an tēhukpo fiot-tē-duk-pen, zer-at.
 that+PPOS s/he that-when-FM rich be(X)-GRD-VIS-RM=PA.PROSP say-EX=ASS.PRS
 ‘For example, I might be his/her neighbour, but would not remember whether s/he was rich or not. [But] I would remember this: s/he had a house [and] s/he had a car. Therefore I (would) say: s/he must have been rich also at that time.’
- (79) Tyaksipa (Eastern Baltipa, 2022), *About real education*
saaq zer-khan d+o in :
 lesson say-NLS that+DF be.ASS
gasu-la inmen-po fes-et.
 whoever-AES right.wrong-DF know-EX=ASS.FUT/HAB
gasu mintaks-ika saaq zer-khan duktuk,
 whoever by.name-PPOS lesson say-NLS be.PRB

⁷⁵ The modal status of these forms is somewhat problematic. Baltipa *-(t/n)uk* is described as non-epistemic future by Biemeier (1985: 107f.) for all persons, including 1P, and the same holds for both the simplex and the compound forms in Ghulam Hassan Lobsang (1995: 33; only examples for 3P are given). Jones (2009: 36f.) describes *-(t/n)uk* as future under ‘modality’. In her example 19 (p. 37), she translates of *zer-uk* as ‘may/will say’, that is, with a possible epistemic reading of probability. *-duktuk* is listed as a periphrastic future under ‘inferential’ (p. 37), but then translated as non-epistemic future with a first person (p. 37, ex. 20). Read (1934: 43f.) describes *-(t/n)uk* as expressing future, and *-duktuk* as signalling “strong probability”. Zemp (2018) describes both forms for the Purikpa dialect of Kargilo as epistemic ‘potential’ markers. In my data from the Turtuk area, *duktuk* appears with *faet* ‘perhaps’ and in irrealis, imaginative contexts, while *-(t/n)uk* has been described by the Tyaksipa speaker as indicating that there is a condition. It thus has an epistemic connotation. The obviously related form *-tuk* in the Western Shamma dialects can have a counterfactual meaning of regret. The less obviously related shortened forms *-ok/-uk/-ak*, plus Western Shamma *-(p/b)-ok* and Kenhat *-k(an)-ak* (negated *-ka-m(an)-ak*) are used as future inferentials.

amma kho-eanu inmen-i fes medaŋ
 but he-PPOS right.wrong-GEN knowing NG.exist.EXP
mintaks-na kho saaq zerkhan men.
 by.name-ABL he lesson say-NLS NG.be.ASS

‘A [truly] educated person is that one: whoever knows right and wrong. Whoever might be educated on the paper (lit. on the given name), but does not know right and wrong (lit. but there is no knowledge of right and wrong in him), he is actually (lit. [apart] from the given name) not educated.’

- (80) Tyaksipa (Eastern Baltipa, 2022), *About addressing others*

misal, su-tfig-i lo sumfu duktuk.
 for.example who-LQ-GEN year 30 be.PRB
kho-si su-na spera taŋ-et-na,
 he-ERG who-COM speech give-EX-CD
de mi lo nijunis ja kapfu duktuk.
 that person year 40 or 50 be.PRB
ta kho-si e mi-u-la apo ja api zer-uk.
 now he-ERG that person-DF-ALL grandfather or grandmother say-PRB
gj+u ljaxmo zosta men.
 this+DF good manner NG.be.ASS
kho-la khuri naso-saŋ samb+eaŋ jak-pa-rgos-et.
 he-AES he.GEN age-FM thought+PPOS put-NLS-need-EX=ASS.PRS

‘For example, someone might be 30 years old. If he talks to someone, that person might be 40 or 50 years old. Now he might call that person grandfather or grandmother [in absolute age-related terms]. This is not a good way. He needs to take into account his [own] age, [and thus use the relative term corresponding to the age difference].’

In the Lehpa dialect, the distance marker *-kjak* is very common in such settings. Rebecca Norman (p.c. 2016) told me that she had commonly heard its usage, and initially rather disliked this way of speaking, as she thought it was pejorative, especially in combination with a second person pronoun. But, in fact, the Kenhat distance markers, the Shamskat inferential-*cum*-distance marker *-suk/-sok*, and the GEM only indicate that the situation is imaginative.

- (81) Lehpa (Kenhat, Central Ladakhi, second generation, field data 2017)

ŋa gowa in-kjak. tene kheraŋ julmi-zik in-kjak.
 I village.head be-DST then fam.you villager-LQ be-DST
tene kheraŋ-a rafen nuun thop-kjak. ...
 then fam.you-AES ration few get-DST

‘[For example,] I would be the village head [and] you would be a villager. [And] you would have got too few of the rations. ...’

The inferential-*cum*-distance marker and the corresponding compound form of the copula, the GEM, are the natural choice for speakers of the Western Shamma dialects.

- (82) Tagmacikpa (Shamskat, Western Shamma, field data 2019)

rpe+k bor-na, kheraŋ gaid intsok.
 example+LQ put.down-CD fam.you guide be=GEM
kherā-a klain khontaŋ fik-na-fik thap-khan rŋa jot-sok.
 fam.you-AES client they(incl) one-COM-one quarrel-NLS 5 have-INF/DST
nimatshere khoŋ-un thab-en-dug-et-sok.
 day.long they-PL quarrel-CNT-stay-EX-INF/DST
 ‘For example, you **would be** the guide. You would have 5 clients who would quarrel all day long with each other.’

While Shamskat *intsok* may be treated as being ambivalent between an epistemic and an extended irrealis reading, the occurrence of *inok* in the Southern Shamma dialect of Lingshet, example (83), and *hinak* in the Upper Indus dialect of Çara, example (84), can only be interpreted as an extended irrealis function.

- (83) Lingshetpa (Shamskat, Southern Shamma, field data 2016)

rperna ŋa gowa inok. kheraŋ julpa inok.
 e.g. I village.head be=GEM you villager be=GEM
ŋa-s kheraŋ-a las maŋbo taŋ-et ...
 I-ERG you-ALL work much give-EX=ASS.PRS
 ‘For example, I am/ **might be** the village head. You are/ **might be** a villager. I give you a lot of work ...’

- (84) Çarapa (Kenhat, Upper Indus dialects, field data 2016)

*pē:(.)naŋa, ŋa goba hinak. / *hin-tsuk. / *hin-kak.*
 example+PPOS I village.head be=GEM *be-MDST *be-DST
khjoraŋ julpa hinak. kho hunma hinak. ...
 fam.you villager be=GEM s/he thief be=GEM
 ‘For example, I am/ **might be** the village head, you are/ **might be** a villager, [and] s/he is/ **might be** a thief. ...’

The alternative use of distance markers, probability markers, and the GEM, whether here or in narratives or in play role or stage directions, indicates that the GEM is not simply a neutral form, but competes in its original epistemic function with other epistemic markers in irrealis contexts.

A quite similar imaginative extended irrealis usage of the past ‘factual’ marker *pa-red* is found in Standard Spoken Tibetan, while in Denjongke, the so-called ‘neutral’ copula *be*² is used.

- (85) Standard Spoken Tibetan (Oisel 2017: 106, ex. 38, transliteration and glossing adapted)

pē:na tēhāca²-na ŋ·ε⁷⁶ khāla² sɔ²-pare²-ta
 example put.down-CD I+ERG meal prepare.PA-FACTUAL.PAST-QUESTION.TAG
 ‘For example, let’s say, I cooked!’

⁷⁶ Oisel (2017) uses an apostrophe for the glottal stop or unreleased final consonant, as well as for what other authors describe as a falling tone contour and lengthening in the case of a lost final -s, thus low tone *ŋε:* (< *nas*) and *sɔ:* (< *zos*). In other cases, such as the genitive, the author gives a length distinction.

(86) Denjongke, Sikkim (Yliniemi 2019: 367, ex. 9.20 glossing adapted)
ʃeŋge: lo p^hate t'iwa ɲà t'i-ɛɛ bɛ?
 hon.you_DATIVE thither question I ask-NLS(GRD) CP.NEUTRAL
 '(Let's imagine) I'll ask you a question.'

(87) Denjongke, Sikkim (Yliniemi 2019: 367, ex. 9.19 glossing adapted)
ɲà gju-do bɛ?, t^ha:riŋ, kor bak-ti.
 I go-CNT CP.NEUTRAL far.away tour carry-CC
 [The speaker has asked the addressee to transfer a handsome sum of money. Upon being asked what he would do with the money, he replies:] 'I'm going, far away, roaming around.'
 Perhaps better: '[In that case,] I **might be going**, ...'

Additionally, one can find *yod.red* in past counterfactual constructions, another irrealis context for which, however, in the Ladakhi dialects only the various distance markers are used.⁷⁷

(88) a. Standard Spoken Tibetan (Denwood 1999: 160, glossing adapted)
*mɛ̃: di sɛ-bə-ji-nə sɔgbu debu tɛhā:-dɛ:-jɔ:re?*⁷⁸
 medicine this eat.PA-NLS-CP-CD body well become-stay-PERF.FACTUAL
 'If [I] had eaten this medicine, [I] **would have got** better.'

b. Standard Spoken Tibetan (Tournadre & Sangda Dorje 1998: 167, adapted)
kam-la kotɛa? kjap-na, tɛāla? lā-jo:mare?
 box-ALL lock apply.PA-CD thing get.lost-NG.PERF.FACTUAL
 'If [we] had put a lock on the box, the stuff [inside] **would not have got lost**.'

3.2.4 *Planning, suggesting, and explaining (profiling the interests of the addressee)*

The imaginative function of the construction V-GRD-GEM is commonly used across almost all dialects as a strategy for avoiding commands, and more particularly for planning, inclusive stage directions and play roles, advising, suggesting, or also wishful thinking, concerning both the MSAP and OTHER. Accordingly, the phrase *thopʃanok* 'will likely get' of example (66) in section 3.1.5 could also be used as encouragement when giving some advice about selling the *snambu*. Similarly, the phrase *thopʃeno*⁷⁹ 'will/ may find' of example (68) in section 3.1.5 might be used, when explaining how one could or should arrange books in a shelf for oneself or others. The gerundive construction with the GEM may also be used when explaining technical functions, (95), one's own individual future situation, (96) second part, or a generic fact, e.g., examples (89) and (100).

In a related function, the construction with GEM also appears in the Eastern Purikpa dialects as an auxiliary in questions that seek an advice or suggestion, cf. the contrast between an information-seeking question in (91) and (92) and the rhetorical question in (92), second alternative. It is possible that answers to such questions may take the same form, but they are still missing in my data.

Rev1 suggests that this construction refers to a "pre-existing plan, which is not the same as when you're making plans while speaking." This may well be the case in most instances. The same would be true, however, for many instances of imperatives. Whether the speaker already has a plan or not, thus, does not make the difference between the gerundive construction with the GEM and

⁷⁷ Note, however, the use of the inferential-cum-distance marker *-suk* in the protasis of counterfactual conditionals in several Eastern Baltipa dialects, cf. Jones (2009: 50).

⁷⁸ The phonological transcription should possibly look more like *mɛ̃: t̃i sɛ:-pa-ji-na, suku tɛpo tɛhā²-tɛ²-jɔ:re?*

an imperative. The difference lies in the tone or attitude, the imperative being a straightforward command, potentially impolite, while the gerundive construction with the GEM may express a *command in guise of a mere suggestion*. Similarly, the assertive future tense constructions with Set I markers (*-et* or *-in*) indicate that the speaker has made a decision to act in a particular way, and that means s/he has a pre-existing plan. When the speaker uses the gerundive construction with the GEM for something s/he intends to do, this can again be seen as a *decision in guise of a suggestion*. Whether planning for others or for him/herself, the speaker, at least formally, presents the ‘pre-existing plan’ in such manner that it can be opposed or questioned more easily by the addressee, and so will be seen as less harsh or more polite.

Nevertheless, there are also examples, where the plan or suggestion is made on the spot, see examples (97) a., (102), (103), and (105). Besides these, with the questions in examples (91) and (92) the speaker asks for a spontaneous suggestion, not for an already existing plan.

As already mentioned, the construction may be used also for explanations and generic facts, examples (95) and (100) for the latter function. In this function, the construction competes with the neutral future construction *V-GRD-yin*, cf. (95). While the latter construction implies that the speaker has observed the fact personally several times, the use of the GEM apparently shifts the focus onto the sharedness and shareability of the observation and so defocuses from the addressee’s knowledge gap.

In example (89), from the Western Purikpa dialect of Kargilo, the speaker, according to Zemp’s (2018: 574) translation, seems to focus on what the addressee wants to know. The same may be true for example (90), which might fall under the explanatory stance. Here, the first speaker asks for confirmation, using the neutral gerundive construction with the plain copula. The answer, however, is with the GEM, which apart from confirming may also have a connotation of appeasing or assuaging the addressee’s fears or doubts. In both examples, there is no indication that *insuk* is used for an inference or assumption concerning the content of the statement. With respect of (90), Zemp only comments that “while the indefinite article *-fik* [in the first part] indicates some reservation in the question, its lack in the answer indicates that the speaker *knows for a fact* that the video taken with his camera will have sound *because it always has*” (Zemp 2018: 860, emphasis added).

(89) Kargilopa (Western Purikpa, Zemp 2018: 574, ex. 811, slightly adapted)

ʂtswa za-ʃ-in-suk.

grass eat-GRD+CP-INF/DST (=GRD+GEM)

‘[The cows] eat grass. (Is that the answer you were looking for?)’

(90) Kargilopa (Western Purikpa, Zemp: 2018: 861, ex. 451, slightly adapted)

[A:] *p^huʈu spera zer-en-ʃik biŋ-ʃ-in-a?* –

photo speech say-CNT-LQ come.out-GRD+CP=FUT-QM

[B:] *spera zer-en biŋ-ʃ-in-suk.*

speech say-CNT come.out-GRD+CP-INF/DST (=GRD+GEM)

[A:] ‘Will the video (lit. photo) also have sound?’ – [B:] ‘Yes, **it will have** sound.’ ([Don’t worry,] “**because it always has**”.)

(91) Ciktanpa (Shamskat, Eastern Purikpa, field data 2016)

ta ŋa-s / ŋates ʃi ba-ʃ-entsuk?

now I-ERG we.incl.ERG what do-GRD+GEM

‘Now, what **should** I / we **do** (any suggestion)?’

- (92) Ciktanpa (Shamskat, Eastern Purikpa, field data 2016)
pene ski-se-khjoŋ-ŋfas-po [k_{ho}-s / ŋa-s] *mana kalat bas-(s)uk.*
 money borrow-LB-bring-GRD-DF [s/he-ERG I-ERG] ever wrong do.PA-INF/DST
ŋfia zer-na, kho-a / ŋa+(.) nokari met.
 why say-CD s/he-AES I-AES government.job NG.have.ASS
 [k_{ho}-s / ŋa-s] *ŋfi ba-se pene ldzok-ŋf+entsuk? / ldzog-et?!*
 [s/he-ERG I-ERG] what do-LB money return-GRD+GEM return-EX=ASS.PRS/FUT
 ‘Borrowing [that much] money, [s/he / I] made a mistake (as I realise). Because s/he doesn’t / I don’t have a government job. [So] how **can** [s/he / I] **pay** the money **back** (**any suggestion**)? / how could [s/he / I] ever pay the money back?!’⁷⁹
- (93) Tagmacikpa (Shamskat, Western Shamma, field data 2019)
tshanma-la dzule.
 all-ALL greetings
goba membar amatshokspa ŋifar studen,
 village.head village.assistant woman.group teacher student
tshanma+(.) dika dzom-ŋfaz-la rgasus zu-in,
 all+ALL here gather-GRD-ALL welcome hum.tell-CP=ASS.FUT
dene deriŋ ŋataŋ-is pikŋfar ŋta-ŋfa-intsok. ...
 then today we.incl-ERG film watch-GRD-GEM
khon-is pikŋfar takpo manbo ŋfo-khantsok.
 hon.s/he-ERG film great many do-DST
de-aŋna pikŋfar ŋfikŋfik ŋataŋ-is deriŋ ŋta-ŋfas-intsok.
 that+PPOS:ABL film single we.incl-ERG today watch-GRD-GEM
 ‘Greetings to all. [Dear guests], village head and village assistant, [members of the] Women’s Alliance, teachers and students, [I’d like to] welcome [you] all for coming together here. Then today, **we shall/ let us watch** a film. ... He [the filmmaker described in the elided passage] has made many brilliant films (as I can gather [from the critics]). **We shall/ Let us** now **watch** one of these films.’ (This would be an official introduction in a gathering; the introduced person would be known by most people in Ladakh.)
- (94) a. Tagmacikpa (Shamskat, Western Shamma, field data 2019)
askja ŋataŋ ŋug-ika biŋ-ŋf+entsok.
 tomorrow we.incl 6-PPOS get.out-GRD-GEM
ŋentaŋ-is buŋ gon-ŋf+entsok, koaŋ dŋonmo gon-ŋf+entsok,
 hon.you.(incl)-ERG boot dress-GRD-GEM coat warm dress-GRD-GEM
jaŋ mikfel tak-ŋf+entsok.
 again glasses wear-GRD-GEM
 ‘Tomorrow, we **will start** at six (**as per the plan**,). You **should put on** boots, a warm coat, and [sun] glasses.’ (The guide talks to the clients.)

⁷⁹ Note that the assertive form *ldzog-et* ‘will return’ is used for a rhetorical question, and as such may refer to third persons and first persons alike.

b. Tagmacikpa (Shamskat, Western Shamma, field data 2019)
kheraŋ gaid̪ intsok. khoŋ-naŋambo tuŋ-ika biŋ! / biŋ-tʃ-entsok.
 fam.you guide be=GEM they-PPOS:COM 6-PPOS get.out.IMP get.out-GRD-GEM

jaŋ tshaŋma sŋon-zig-a kur taŋ-ba-a tʃha-tʃ-entsok.
 again all early-LQ-ALL tent give-NLS-ALL go-GRD-GEM

‘You will be the guide. Start with them at six! / (**As per the plan**) [you] **will** start with them at six. And [the others] **will/ shall** all go first, in order to put up the tent.’ (The agent talks to the guide. The imperative (*biŋ*) conveys a strict order, which may be somewhat unexpected for the addressee. / The construction with the GEM (*biŋtʃentsok*) refers to a plan, which the addressee is expected to know. It serves thus more as a friendly reminder than as a command. Cf. the parallel example (101) from the Faɖumpa dialect.)

(95) Domkharpa (Shamskat, Western Shamma, field data 2017)

d-u di.es.pi.ti intsok. di.es.pi.ti(·)kana foun tʰeŋ-tʰana,
 this+DF DSPT be=GEM DSPT+PPOS:ABL phone give-when

pene tsapik phok-tʃ-en. / &phok-tʃa-intsok.
 money a-bit hit-GRD+CP=FUT &hit-GRD+GEM

dika su-i foun joŋ-na, nambar
 here who-GEN phone come-CD number

biŋ-tʃ-en. / &biŋ-tʃa-intsok.
 come.out-GRD+CP=FUT &come.out-GRD+GEM

ŋataŋ tshaŋm+ebarla di foun tʃikʃikpo mene met-pa-intsok.
 we.incl all+PPOS this phone single except NG.exist-NLS-GEM=PERF

defia d-u [r]demo ba-se kol-tʃik!
 therefore this+DF properly do-LB apply.IMP-DM

‘(Let me explain,) this is a DSPT (Digital Satellite Phone Terminal, a communal device for villages that have no landline or tower). When making a call from the DSPT, one **will have to pay** some money. Here, the number **will show** [of those] whose call is coming in. There is only a single phone for (lit. between) us all. Therefore, [you] must use it carefully.’ (The speaker explains the new device in the village assembly.⁸⁰)

In the Western Shamskat dialects, the gerundive construction with the plain copula is used neutrally for future situations concerning all persons and for generic facts (which the speaker has personally observed). However, in an **official setting**, the gerundive construction with the GEM as in the above example (95), line 2 and 3 is definitely preferred.

⁸⁰ Rev1 opines that the explanations about phones, here and further below, would be artificial (see also examples (172) and (174)). Rev1 is apparently not aware about the situation on the ground. None of the informants found the context artificial, because it was taken from their experience, if only from a few years earlier. Many villages of the remote areas never had a landline connection. The use of mobile phones was permitted in Jammu & Kashmir only from the year 2003 onwards, and for quite some time, not every remote village had a tower. E.g., Gya-Miru had none until around 2019, and before that, in 2016 or 2017, the villagers had finally got a communal connection, similar to that described in the above example. While the younger people of the urban areas used mobile phones right from the beginning, and switched to smart phones, as soon as they could afford them, elderly persons did not necessarily feel the need to do so; and if so, they started with simple mobiles. Even my host in Leh, switched to a smart phone only around 2018, after she was given one by her children, and she then repeatedly asked me for help.

- (96) Kārgyampa (Kenhat, Lalokpa, field data 2019)
ŋa nāa t̥o+i-indak. / t̥o+i-mak.
 I bride do·GRD-GEM do·GRD-NG.GEM
 ‘I **am going to be** married (it is decided, everyone agreed and **everyone knows**). / I’m **not going to be** married ([announcement with **explanation to follow**]: because something happened against the plan).’
- (97) a. Gyaikpa (Kenhat, Upper Indus dialects, field data 2017)
t̥erij kh+e k̥elak p̥e d̥eō gon-de-duk.
 today s/he+ERG dress very nice dress-LB-VIS=PERF
t̥e(·)fia oyo-aŋ d̥eō gon-ge+çe-inak.
 therefore we.incl-FM nice dress-need+GRD-GEM
 ‘S/he wears/ has put on very nice clothes today. Therefore, we, too, **should dress up** nicely.’
- b. Gyaikpa (Kenhat, Upper Indus dialects, field data 2017)
thore ŋ+e thukpa k̥ōl-t̥e+enak.
 tomorrow I+ERG soup boil-GRD+GEM
 ‘Tomorrow, I’ll prepare the soup (**as planned**, as it is my turn).’
- (98) Kyungyampa (Kenhat, Lalokpa, field data 2019)
thore oy+e hura t̥ē-t̥e-inak.
 tomorrow we.incl+ERG canal do-GRD-GEM
 ‘Tomorrow, we **have to/ are supposed to** repair the irrigation canal.’ (The task was decided in the meeting, the speaker is spreading the message.)
- (99) a. Gya-Mirupa (Kenhat, Upper Indus dialects, field data 2019)
thore ɖagɖar tshaŋma kjōt-t̥e-inak.
 tomorrow doctor all hon.come-GRD-GEM
t̥efia gow-e khoŋ-gun-a kjōd_ zi-re soldza phul-se+nak.
 therefore village.head-ERG they-PL-ALL come request-LB hon.tea offer-GRD+GEM
 ‘Tomorrow the doctors **are coming (as planned)** [for a health camp]. Therefore, (**it is planned that**) the village head **is offering** them welcome tea.’
- b. Gya-Mirupa (Kenhat, Upper Indus dialects, field data 2019)
khjoraŋ gjafo hin-tsuk; itsok t̥ē-re, khjore itsok p̥era-zik zer-t̥e-inak.
 fam.you king be-MDST this.like do-LB fam.you.ERG this.like speech-LQ say-GRD-GEM
 ‘You will be the king; acting like this you **will (have to) say** your line like this.’ (**Prescription by the stage director.**)
- (100) Gya-Mirupa (Kenhat, Upper Indus dialects, field data 2005)
ab+e ziŋkaŋ kh+e p̥utsa+(·) ɖzak-t̥e-inak.
 father+GEN field.house s/he+GEN son+ALL be.passed.on-GRD-GEM
 ‘A father’s estate will be passed on to his son(s).’ (This is a **generally known fact.**)⁸¹

⁸¹ Women still have no inheritance rights. The Buddhist Right to Succession Act dated 14th June, 2000 (Samvat, i.e. 1943), which specifies the “Right to all sons to succeed in equal shares” can be found under <https://jk.gov.in/jammu-kashmir/sites/default/files/2197.pdf>; https://www.indiacode.nic.in/bitstream/123456789/5860/1/ladakh_buddhistsuccession_to_property_act_2000.pdf. The act has not been revoked by The Jammu And Kashmir Reorganisation Act, 2019, see *The Gazette of India*, No. 53, August 9, 2019, available under <https://egazette.nic.in/WriteReadData/>

- (101) Faḍumpa (Kenhat, Central Zanskarpa, field data 2019)
thore hayo namo-ne galḍi tuḡ-ika i-ne biḡ-tfe+no?
 tomorrow we.incl morning-ABL clock six-PPOS this-ABL go.out-GRD+GEM
kheraḡ buḡ jela-zi? kon-tfe+no?, migra-zi? kon-tfe+no? ...
 fam.you.self boot good-LQ wear-GRD+GEM glasses-LQ wear-GRD+GEM
te raḡraḡ soso-e fhu khur-fe+no? ...
 then self.self different-GEN water carry-GRD+GEM
 ‘Tomorrow in the early morning at six o’clock, we **shall leave** from here. You **should wear** suitable boots. [You] **should wear** [sun] glasses. ... Then everybody **should carry** his/her own water. ...’ (The group leader **communicates the schedule** in which s/he includes him/herself and further **gives some advice** more specifically to the addressees, although the group leader will certainly also act accordingly.)
- (102) Faḍumpa (Kenhat, Central Zanskarpa, 2022), *The first cigarette*
tsuntse-zane, ḡa+(.) aḡo sigreḡ thũ-la thoḡ.
 be.small-when I+AES elder-brother cigarette drink-FM see=PA
tene kh·œ ḡa lyi-ḡe kher-ḡe ḡa-la thuḡ-fḡi ta, tsawi-fi.
 then s/he+ERG I placate-LB take.away-LB I-ALL drink-LQ give=PA a.bit-LQ
tekane kh·œ lo : «ta ma-thuḡ-wa! jafa fḡe-tā-e+no?» lo. /
 thereafter s/he+ERG say now NG-drink=PRHB-emp fun do.PA-give-NLS+GEM=DPG QOM
 «... *jafa fḡe-ḡe-in» lo.*
 fun do.PA-LB-CP=PERF QOM
«ta ḡa-la thuḡ-tfe+ma?, kherā-la thuḡ-tfe+ma?
 now I-FM drink-GRD-NG.GEM fam.you-FM drink-GRD-NG.GEM
jaḡ θiḡne thu-a thoḡ-ne, ḡuḡ-en» lo.
 again afterwards drink-NLS see-CD beat-CP=ASS.FUT QOM
 ‘When I was small, I [once] saw my elder brother smoking. Then he took me along, placating me, and let me take a draw, a little bit. Thereafter he said: «Now don’t smoke/ stop smoking, hey! [I] was [only] making fun, right? / ... [I] definitely [only] made fun.» [He] said «Now, I **shan’t smoke** [and] you **shan’t smoke** either. And [I]’ll beat [you], if [I] see [you] smoking later on,» [he] said.’ (With the gerundive construction and the GEM, the brother develops a plan on the spot for their future behaviour. The suggestive tone contrasts with the subsequent threatening.)

Note the DPG-construction (on which sections 3.4.5 to 3.4.7) in line 3, used here for a first person subject. Here, it potentially signals the speaker’s regret, upon realising his mistake but it may also have a more persuasive connotation.

The prospective construction is especially common in combination with the modal verb *ḡgos* (*rgos* ~ *gos* ~ *yø* ~ *ge(s)* ~ *gi*) ‘need’. In contrast to a command or other, more direct forms of the modal, the GEM conveys the connotation of a mere suggestion.

- (103) Tagmacikpa (Shamskat, Western Shamma, field data 2019)
d+u thaktfade thik mentsok! su in-(n)a+η, fi ba-na+η,
 this-DF definitely okay NG.be=GEM who be-CD+FM what do-CD+FM
ges-ηun-la rdemo ba-se spera taη-rgos. / taη-rgo+f+intsok.
 guest-PL-ALL nice do-LB speech give-need give-need+GRD+GEM
 ‘This is certainly not okay! Whoever [it] is, whatever [anybody] does, [you] must / [one] **should talk** quietly to the guests.’ (Teaching how to behave as a guide.)
- (104) a. Kārgyampa (Kenhat, Lalokpa, field data 2019)
oyo tshaηma teiktetik teō-re kūteo tāη-go.
 we.incl all single do-LB shouting give-need
 ‘We all need to unify and shout/ raise our voice.’ (Neutral statement.)
- b. Kārgyampa (Kenhat, Lalokpa, field data 2019)
oyo tshaηma teiktetik teō-re kūteo tāη-go-çi-indak.
 we.incl all single do-LB shouting give-need-GRD-GEM
 ‘(I think that) we all **should** unify and **raise our voice** (it is important.)’ (The construction conveys a note of **suggestion**, based on more general knowledge.)
- c. Kārgyampa (Kenhat, Lalokpa, field data 2019)
oyo tshaηma teiktetik teō-re kūteo tāη-gos-en.
 we.incl all single do-LB shouting give-need-CP=ASS.FUT
 ‘We all must unify and raise our voice.’ (The assertive future construction conveys a note of commanding, forcing the addressees.)
- (105) a. Gyaikpa (Kenhat, Upper Indus dialects, field data 2017)
khjoraη khjore kelak tshaηma
 fam.you.self you.self.GEN clothes all
i almari+(.)naηne tōn-ge-çe-(i)nak.
 this shelf+PPOS:ABL take.out-need-GRD-GEM
teīfia zer-na, khjo-a ta teēloη me-kak.
 why say-CD fam.you-AES now do.time have-DST
teīfia khjoraη-a, jaη almari soso-zig-enaηa por-na,
 therefore fam.you.self-AES again shelf different-LQ-PPOS put-CD
thik-tcha-tce-(i)nak.
 okay-go-GRD-GEM
 ‘You **should (perhaps) take** all your clothes from this shelf, because you won’t have time now [to put everything in order]. Therefore, you’d **better** put them on another shelf.’ (Speaker and addressee have an argument about the clothes on the shelf; the speaker, in consideration for the addressee, **strongly suggests** an action, rather than commanding it.)
- b. Gyaikpa (Kenhat, Upper Indus dialects, field data 2017)
khjoraη khjore kelak tshaηma
 fam.you.self fam.you.self.GEN clothes all
i almari+(.)naηne tōn-ges-en. η+e kelak tshaηma çik-duk.
 this shelf+PPOS:ABL take.out-need-CP=ASS.FUT I+GEN clothes all ruin-VIS=PRS
khjore mā-ton-na-ne, η+e tōn-de t̃im-taη-en!
 fam.you.self.ERG NG-take.out-CD-TOP I+ERG take.out-LB throw.away-give-CP=ASS.FUT

‘You’ll have to take out all your clothes! [You] are ruining all my clothes [i.e., by bringing them into complete disorder]. If you don’t take [them] out, I’ll throw them out into the garbage!’ (Speaker and addressee have an argument about the clothes on the shelf, and the speaker does not want to consider the addressee’s arguments or look for alternative solutions.)

Given this friendlier or more polite tone of the prospective construction with the GEM, it could certainly also be included in the next section on social conventions.

3.3 *Socio-pragmatic factors and conventions*

3.3.1 *Profiling one’s own subjective relationship of distance or non-involvement*

One of the foremost functions of the opposition between the plain copula and *inok* & siblings is to sort out persons and things into those that one is fairly acquainted with or that belong to one’s (quite elastic) personal sphere or territory of information and those that do not. Hence, when introducing a family member, a close friend, or a well-known member of one’s village (or neighbourhood in Leh), the plain copula will be used, whereas the GEM is used to indicate one’s personal distance, because either the relationship is not particularly close or even broken or the person belongs to a different village. Both the more objective factors (a person belongs to a different village) and the more subjective factors (personal non-acquaintance and emotional non-involvement) may be overridden by the pragmatic consideration that the person in question is present, in which latter case, there is a certain tendency for the copula to be preferred, while the absence of the person may lead to the use of the GEM even for more closely related persons, see also section 3.3.4. In other words, the indication of spatial and temporal distance is also part of the many functions of the GEM. In this section, I want to address only the more standard situations, namely such situations that would find their way into the usual standard descriptions of evidentiality under the heading of ‘factual’.

In my fieldwork, I focused on neutral identifications in the course of a conversation, explicit introductions, and the pointing out of persons on photographs. I neglected to a certain extent how one would ask about persons and how such questions may shape the answer. I realised the importance of the latter context only when writing down examples (1) and (2) above.

As the following Shamskat examples show, the GEM may indicate that one does not know a person well-enough, (108), that one does not feel close enough, (109), or that the person belongs to another village, (107), alternative b., and (111). This may be seen in contrast to a person that belongs to one’s own village and whom one knows well, (107), alternative a. and (110), first sentence. Even Baltipa speakers may use the form *intsuk* to describe a situation with which they do not identify although they know it well, (106). In none of these cases, does the form *intsuk* indicate an inference or a coming-to-know.

- (106) Tyaksipa (Eastern Baltipa, 2022), *Chulungka*
ʃhulunʃka jaŋ loʃso jul in-tsuk.
 Chulungka again different village be-INF/DST(=GEM)
 ‘Chulungka **is** yet another/ a different village. [It’s **theirs not ours.**.]’

Chulungka lies halfway between Turtuk and Byogdang, upstream the last village of the Baltipa-speaking region. Tyaksi lies downstream from Turtuk. The speaker has no doubts. His family has land in Byogdang, and he has been living in Byogdang for some time. It is thus quite

evident that the speaker does not just make an inference, that he has not just heard about the village from others, or that he has not just become aware of the existence of the village or of its being different. One could expect that the speaker talks about something in his personal sphere or territory of knowledge. However, the speaker **does not identify** with that village. According to him, Tyaksi and Byogdang have strong ties through original family relations, whereas the people of Phranu, Thang, Turtuk, and Chulungka form a different group of ‘others’. There are subtle differences in their dialects. It also appears that the people from Tyaksi and Byogdang bear a grudge against (some of) these ‘others’, as some of the latter’s ancestors seem to have appropriated part of the best land.

- (107) a. Wakkapa (Shamskat, Eastern Purikpa, field data 2002)

di mi ɲatʃ-i jul-i gjapo in.
 this person we.excl+GEN village-GEN king be.ASS

‘This man is the chief (lit. king) of our village.’ (The fact falls into the speaker’s territory of information.)

- b. Wakkapa (Shamskat, Eastern Purikpa, field data 2002)

di mi a jul-i gjapo intsuk.
 this man that village-GEN king be=GEM

‘This man **is** the chief (lit. king) of that village over there.’ (The fact falls **outside the speaker’s territory of information.**)

- (108) Ciktanpa (Shamskat, Eastern Purikpa, field data 2016)

di ane-o dʒarmani-na in-ma. / intsuk.
 this woman-DF Germany-ABL be.ASS-emp be=GEM

‘This lady is from Germany. (This is certain, I know her already for a while. / I **know** her **only for a very short time.**)’ (The fact does / **does not fall into the speaker’s territory of information.**)

- (109) Sumurpa (Shamskat, Ldumrapa, field data 2016)

kho stanzin intsuk. / in.
 s/he Stanzin be=GEM be.ASS

‘This (lit. S/he) is Stanzin.’ (The GEM is used for a person **not so close to ‘us’**, that is, for a fact **falling outside the speaker’s territory of information.** [It further indicates new information.] / The plain copula is used for a close friend, or a person the addressee already heard about, hence a fact subjectively belonging to the speaker’s territory of information or a fact where the interests of the addressee no longer need to be taken care of.)

- (110) Tagmacikpa (Shamskat, Western Shamma, field data 2019)

azəŋ-le ɲatʃ-i goba in. miŋ-a tsheriŋ aŋʃuk intsok.
 uncle-hon we.excl+GEN village.head be.ASS name-ALL Tshering Angcuk be=GEM

khəŋ goba ʃo-se lo rdun ʃha-ʃen.
 hon.s/he village.head do-LB year 7 go-GRD+CP=FUT

azəŋ-le jul-iphia datʃan jot. dephia ma-spo-a-bor-e-intsok.
 uncle-hon village-PPOS devoted be.ASS therefore NG-exchange-NLS-keep-LB-GEM=PERF

‘That man (lit. uncle) is our village head. (**Let me explain** that) [his] name **is** Tshering Angcuk. It is going to be seven years, since he became (lit. did) the village head. He cares for (lit. is devoted to) the village. Therefore (as I emphasise for you) [we] did not exchange him.’

In this example, the facts do not belong to the speaker's territory of information alone; all facts are communal knowledge. Nevertheless, the speaker presents the professional identity as unquestionable personal knowledge, while s/he attenuates his/her stance with respect to most further details. This choice may indicate slightly different grades of identification with, or involvement in, the situation. In the case of the professional identity, the speaker practically has no choice than to identify with the enduring situation, as s/he is participating in the hierarchy even if s/he may not have been actively involved in the election of the village head. S/he is certainly not responsible for the village head's name, but should be fully acquainted with him. But the latter does not stand as close to the speaker as his/her family members or friends do. See also p. 110, where example (110) is taken up again as example (192).

The gerundive construction with the plain copula is a neutral form that can be used for habits and generic facts that one has well observed or in which one is or was involved. The assertive existential for the description of the village head's engagement indicates the speaker's subjective assessment, that is, all the same, corroborated as an objective fact by the statement that the villagers did not exchange him. In this last statement, the choice of the GEM as auxiliary for the perfect construction may indicate that the speaker does not bear the sole responsibility and that other villagers were at least as much involved in the decision not to exchange the village head. However, when telling all this to an outsider, the use of the GEM as copula or auxiliary also signals that the speaker is focusing on the addressee's potential interest to know more, downgrading his/her own stance wherever possible.

(111) Tagmacikpa (Shamskat, Western Shamma, field data 2019)

aʒaŋ tiŋmozgaŋ-i goba intsok.
uncle Tingmozgang-GEN village.head be=GEM

jaŋ aʒaŋi miŋ-a padma dorɕe intsok.
again uncle-GEN name-ALL Padma Dorje be=GEM

'That man (lit. uncle) **is** the village head of Tingmozgang [which is quite **far from the speaker's village**]. And his name **is** Padma Dorje.' (The facts clearly fall **outside the speaker's territory of information**.)

Examples (110) and (112) also show that when talking about a person who is somewhat peripheral to one's personal sphere, after the identification with the plain copula, one may continue with the GEM for other details, switching to what I would like to call the 'explanatory mood' and to the profiling of the addressee's potential interest or right to know more, see also section 3.4. The GEM is used in a similar manner in the Kenhat dialects, (112) and (113).

The informant's explanation to example (112) further indicates that one's choices may also depend on to whom one is talking about whom. That is, when talking to one's parents about a close friend, the details will be rendered with the GEM or related forms, but this may not be necessary when talking about one's friend to another person. In other words, one may more likely profile the interests of the addressee the closer the addressee is and the less close the person talked about is, and the other way round. It was explicitly mentioned by the Faɖumpa speaker that the relative distance to the person talked about *and* to the person talked to affects the choice of the markers. In the case of habits, a relatively greater distance could yield the assertive marker *yod* instead of the visual marker *hdug*.

- (112) Lehpa (Kenhat, Central Ladakhi, second generation, field data 2016)

ŋ·e dzamo inok. / in. kho asam-ne inok.
 I+GEN friend.fem be=GEM be.ASS s/he Assam-ABL be=GEM

‘[She] (**who is absent** / who is present) is my friend. (**Let me explain** that) she is from Assam.’ (Introducing a friend to one’s parents. As the informant explains, the GEM would be used when the person is out of sight or when answering a question about the person. / Only the plain copula can be used when the friend is in sight, including on a visual representation (for the factor of distance, cf. also section 3.3.4). When introducing the friend, the plain copula also shows one’s respect for the friend. In the second part, the GEM is used, because, as the informant explains, “**my family is closer to me**; and **I cannot pretend that I know** all aspects of [my friends] life”.)

- (113) a. Gyaikpa (Kenhat, Upper Indus dialects, field data 2016)

tɛ pɔmo su j̄in? / j̄inak?
 that girl who be.ASS be=GEM

‘Who is this girl? / Do you (**by chance**) know who this girl is?’ (The plain copula expresses the expectation that addressee knows the person well and that the fact is part of his/her territory of information, but it is also quite inquisitive. / The GEM is **more neutral**. More importantly, it does not insinuate that the addressee has some peculiar association with, or some responsibility for, the person.)

- b. Gyaikpa (Kenhat, Upper Indus dialects, field data 2016)

kho su j̄inak? – kho gergan soma j̄inak.
 s/he who be=GEM – s/he teacher new be=GEM

‘Who is this? – He is the new teacher.’ (The fact falls **outside the** second speaker’s **territory of information**.)

3.3.2 *A matter of status and authority (profiling the addressee’s interests)*

When talking about facts or situations that are of concern not only for the speaker but also or even more so for the addressee and/ or the whole community, the choice of either the copula or the GEM depends not so much on the question of how one came to know, but on the question of whether one has the right to know it better than the addressee and everybody else. This is also a question of status or formal authority. The use of a Set 1 marker, such as the unmodified copula *yin*, signals that one has exclusive personal knowledge, is actively involved, or that one has or takes the exclusive responsibility for the situation. The signalled claim of exclusive responsibility for a situation that concerns also the addressee may be judged as being presumptuous, and is thus usually avoided. That means that even if one has the best possible ground to know better and even if one has more authority than the addressee (such as, e.g., a teacher *vis-à-vis* a student, parents *vis-à-vis* their children, etc.), one tends to downgrade one’s knowledge state or authority by choosing a form that conveys a connotation of slightly reduced certainty and signals the abandonment of one’s claims to authority, responsibility, involvement, and, above all, exclusiveness. One makes oneself smaller than one is, so to speak, for the benefit of communicative symmetry and harmony. Individual speakers, as well as individual village communities certainly handle this kind of communicative bargaining – individually.

There is further a certain tendency that the obligation towards politeness is felt strongest in the centre around Leh and less strictly in the areas at the periphery, especially at the western periphery. Considerations of politeness are almost absent or perhaps only less evident among the speakers of the

Purikpa and Baltipa dialects. This is well known among the communities. Speakers from Ldumra and Western Sham have described themselves as being ‘impolite’ or at least less polite than the people in Leh. On the other hand, speakers from Western Sham have warned me about people from Wakka-Mulbek in Eastern Purik that they would be ‘hard’, that is, more direct and less polite. Nevertheless, the basic principles are the same across most dialect areas: one tends to downgrade one’s own epistemic status *wherever appropriate*. This will be shown by two examples, one from the western, and one from the eastern periphery.

The first example concerns the essential water rights. Most communities appoint a responsible person, the so-called ‘water master’, who assigns and overlooks the daily distribution of water among the families. As water scarcity has always been a problem, aggravated now by climate change, as well as through the increased cultivation of water-consuming cash crops, unauthorised extraction of water and ensuing quarrels between the involved families are very common. The water master thus has a considerable authority, and in Leh, he or she even has (or had) the right (or obligation?) to beat up a ‘delinquent’ caught red-handed.⁸² In example (114), neither the speaker nor the addressee have particular rights or control over the water usage. As the speaker refers to a fact known by the whole community, s/he uses the GEM neutrally for shared knowledge in alternative a. In alternative b., by contrast, the speaker assumes authority (which s/he does not have) and overrides the convention, indicating thus also his/her anger.

(114) a. Tagmacikpa (Shamskat, Western Shamma, field data 2019)

fhu phut-khan-i khak-po fthurpon-i intsok.
 water release-NLS-GEN responsibility-DF water.master-GEN be=GEM

niri mentsok.
 hon.you.GEM NG.be=GEM

‘The responsibility of releasing the water **lies** with the *churpon* (the elected or otherwise rotating water master). **It’s not** yours. (– And **you know** this very well.)’ (Both speaker and addressee know the fact well. But ideally, only the village head has the authority to use the plain copula in this context.)

b. Tagmacikpa (Shamskat, Western Shamma, field data 2019)

fhu phut-khan-i khak-po fthurpon-i in.
 water release-NLS-GEN responsibility-DF water.master-GEN be.ASS

neraŋ izuk ma-fo!
 hon.you this.way NG-do=PRHB

‘The responsibility of releasing the water definitely lies (only) with the *churpon*. Don’t act like this [i.e. don’t take the water yourself]!’ (Ideally, only the village head has the authority to use the plain copula. Any other householder, even the one affected by the theft, should only use the GEM. However, if we all know it exactly, e.g., because we all were in the meeting where the *churpon* function was assigned, the plain copula *can* be used. The GEM thus signals [if only conventionally] a certain degree of uncertainty [or also non-involvement, while the copula probably signals something like *I know it well, you can’t fool me!*])

⁸² Since a few years, many households in Leh and surroundings have tapped the groundwater, mainly for the tourism business, but also for irrigation, so the situation appears to be less acute, one just runs the pump. Nobody seems to be ready to think of the side effects this uncontrolled extraction may have eventually.

Despite the original functional distribution between the copula *yin* for identifications and the existential linking verb *yod* for the expression of existence and possession, I have come across several instances where the copula *yin* and even more so the GEM are used for existential relations. The dialects or perhaps rather the individual speakers differ somewhat in their usages, whether and to which extent both the plain copula and the GEM may be used, whether only the GEM may be used, or neither. There is one case where the plain copula cannot be used, at all, while the GEM is rather frequent. This concerns the claim of ‘possessing’ a particular shared knowledge, that is, when one wants to say *we all know that X* in a polite way that safes the addressees from losing their face. Most speakers would automatically use the GEM. Only one informant stated that in his village the existential linking verb *yod* would be common, as there would not be any need for being extra polite. Nevertheless, in other places, an addressee might be offended when the existential linking verb *yod* is used, because the use of *yod* signals that the speaker knows better than the addressee does about what the latter knows or has to know.

When I came across this usage, and when we had discussed it in detail, I developed a mini-drama with the informant from Shachukul, in which the negative reaction of the addressee upon the use of the plain existential is illustrated. I gave the outlines in English and the informant translated it sentence by sentence. When we finished, she commented: “this happens every day”, referring to similar situations of apprehension in reality. In (115), I summarise the context.

(115) Shachukulpa (Kenhat, Lalokpa, field data 2016)

A student belonging to the village was expected to make an important list together with the other villagers. In the meeting, the village head had told everybody to come on time next morning at 10 o’clock, but nobody came in time, and some people did not come, at all. The student was quite frustrated and went to search the villagers, telling them:

«*dan tap fō-han-nanzin oyo tshañma+(.) gju hot:*
yesterday meeting do-NLS-according we.incl all+AES knowledge have.ASS
terij garj fū-ika dzom-fī, hīnanj su-aŋ tu-ika mā-lep.»
today clock 10-PPOS meet-GRD but who-FM time-PPOS NG-arrive=PA
‘«Following yesterday’s meeting, all of us **know it well (authoritative stance)**: today [we were supposed] to meet at ten, but nobody came on time.»’

tene āa-zig-a so hoŋ-de,
then mother-LQ-AES anger come-LB
«*khjoraŋ su_ hīn, ŋet tshañma+(.) gju hot zer-kan?!*
fam.you.self who be.ASS we.excl.coll all+ALL knowledge have.ASS say-NLS
khjoraŋ toruŋ datpa ma-tsho-a-hīndak!
fam.you.self still brain NG-ripe-NLS-GEM=PERF
ŋe-a terek zer-fī fī_ in?!
we.excl-ALL such say-GRD what be.ASS
gow+e terek zer-na+ŋ dik.
village.head+ERG such say-CD+FM be.okay
hīnanj khjot su_ in?!»
but fam.you who be.ASS

‘Then one lady (lit. mother) became angry [and said]: «*Who are you* to tell us <that we all **know it well (authoritative stance)**?! You are, as it appears, still wet behind the ears!

What [kind of manner] is this, talking to us in this way?! If the village head speaks like this, it is/ will be okay. But who, [do you think], are you?!»

When the student complained to the village head, the latter was also not amused. He went to that lady and made a scene, himself:

«*daŋ tap fō-han-naŋzin oyo tshayma·(:) gju fiot:*
 yesterday meeting do-NLS-according we.incl all·AES knowledge have.ASS
teŋiŋ gaŋi fū-ika dzom-fi fō-re, khjoraŋ fīphia tu-ika mā-lep?
 today clock 10-PPOS meet-GRD do-LB fam.you.self why time-PPOS NG-arrive=PA
jaŋ fīphia tū-a nāt tu-pen?»
 again why youngster-ALL blame dig-RM=ASS.PA
teŋe āa kha daŋ-de-lu.
 then mother mouth gape-LB-be.left=PA

‘«Following yesterday’s meeting, all of us **know it well (authoritative stance)**: it was agreed to meet at ten today, so why didn’t you come on time? And why did you wrongly scold the youngster?» Then the lady couldn’t say anything any more (lit. was left with a gaping mouth).’

As one can assume, the knowledge state of all three fictive persons would be the same, that of the student, that of the lady, and that of the village head. All three would have been in the meeting and would have been involved in the decision making, if only as witness. The fictive student speaks with *not-at-issue* authority, legitimised by the decision and backed by the authority of the village head, or so s/he thinks. But the fictive lady rejects this authority on the pretence of the student’s age-related low status. She would have preferred the student to use the less authoritative *at-issue* form *gju hindak* with the GEM. Of course, the lady simply does not accept being criticised. She has to accept, however, the authority of the fictive village head, *qua* his position.

As already mentioned, speakers of different dialects differ somewhat in their choices. For the Mūtpa speaker, the use of the existential linking verb poses no problem; it conveys a more certain expectation that the addressee also knows or should know the relevant fact, whereas the GEM signals a mere assumption. By contrast, the Faḍumpa speaker stated that only the GEM is possible when the inclusive plural is used.

Such pragmatic restrictions with respect to shared knowledge do not only concern the use of the existential linking verb *yod*. When talking about past activities in which both the speaker and the addressee were involved, the use of the remoteness marker *pin* (belonging to Set 1 for the MSAP’s authoritative or committed knowledge) is avoided in neutral contexts by most speakers, as it would signal that the speaker knows better than the addressee knows or that the speaker has the sole responsibility. It is only in contexts where the addressee does not remember, that the marker may be used, and even in such situations, individual speakers may avoid its use.

3.3.3 Who am I? Who is this? *Talking gently to small children (profiling their knowledge state and the social interaction)*

When talking to small children, the GEM is commonly used in quite a playful manner. A very common usage is to ask the child about the identity of a person who is coming for a visit or is just entering the room. Several times, I have been the object of that question, but I have also observed one aunt asking her niece about herself. The usage has so far been attested in all Ladakhi dialects and in the Baltipa dialect of Turtuk. Some informants commented that the speaker assumes that

the child does not or may perhaps not know (Sankoopka, Mulbekpa, and Lehpa). But the child usually answers in the same tone, even when referring to his or her close relative. In 2019, the Faḍumpa informant explained that the question might well be used when the children are expected to know. In order to demonstrate this, he asked his 8-year-old niece who lived in the same extended household, and her reaction was spontaneous and as predicted, see example (123). On the other hand, the Sankoopka informant stated that one would use this form only for very small children, up to 2 years of age, and these children would not be able to answer properly. If one would ask an 8-year old child with this form, s/he would only lough. The Mulbekpa informant stated that if the child would know, she would use the plain copula. The Lehpa informant suggested that this way of speaking occurs mainly during the time when the child has to learn the family relations. There is thus some variation in the usage or in the reflection about the usage across the dialects. In the following, I shall present only a selection of the attested examples, but the data is summarised in Table 9.

dialect	region	form	assumed knowledge of child
Turtukpa	Eastern Baltipa	<i>in-maŋ</i>	no comment (expected to know)
Sumurpa	Ldumrapa	<i>intsuk</i>	no comment (expected to know)
Sankoopka	Southern Purikpa	<i>in-tsuk</i>	expected not to know, only very small children
Mulbekpa	Eastern Purikpa	<i>intsuk</i>	not expected to know
Ciktanpa	Eastern Purikpa	<i>intsuk</i>	expected to know
Tagmacikpa	Western Shamma	<i>intsok</i>	expected to know
Lingshetpa	Southern Shamma	<i>inok</i>	no comment (expected to know)
Lehpa 2 nd genr.	Central Ladakhi	<i>inok</i>	the child still has to learn the relations
Rumbakpa	Central Ladakhi	<i>inok</i>	expected to know; <i>yin</i> not possible when asking about oneself: “sounds as if I lost my memory”
Kyungyam	Upper Indus	<i>j̄inak</i>	no comment (expected to know)
Gyaikpa	Upper Indus	<i>j̄inak</i>	expected to know; answer: “I remember”
Gyerepa	Upper Indus	<i>j̄indak</i>	expected to know
Mūtpa	Tibetan border	<i>j̄indak</i>	friendly teasing of child, who is expected to know
Kharnakpa	Himachal border	<i>j̄indaʔ</i>	speaker wants the child to know exactly
Faḍumpa	Central Zanskarpa	<i>inoʔ</i>	expected to know, answer by 8 year old niece
Pangipa	Himachal enclave	<i>j̄inne</i>	expected to know; answer: “I know”

Table 9 Use of the GEM and expectation concerning the child’s knowledge

(Shading is used for those few cases where the informants explicitly stated that the children might not yet know.)

(116) Turtukpa (Eastern Baltipa, field data 2017)

ge nene su_ in-maŋ? – *gj+u aʃurp+i nene in-maŋ.* –
 that aunt(FS) who be-EXP(=GEM) this+DF Aʃur.people+GEN aunt(FS) be-EXP(=GEM)
ŋa su_ in-maŋ? – *ja.ŋ momo in-maŋ.*
 I who be-EXP(=GEM) hon.you uncle(MB) be-EXP(=GEM)

‘Who **might** this aunty (father’s sister) be? – This **is** the aunt from the Aʃur family. – Who **might** I be? – You **are** [my] uncle (mother’s brother).’

- (117) Sankooa (Southern Purikpa, field data 2022)
ŋa su in-tsuk, i-u su in-tsuk?
 I who be-INF/DST(=GEM) this-DF who be-INF/DST(=GEM)
 ‘Who **am** I, who **is** this?’ (This could only said to very small children up to two years, who would not be able to answer properly. – This indicates that **the child is not expected to know.**)
- (118) Mulbekpa (Shamskat, Eastern Purikpa, field data 2016)
ŋa su intsuk? – ane in.
 I who be=GEM aunt(FS) be.ASS
 ‘Who might I be? – [You] are [my] aunt (father’s sister) (as I know).’ (Talking nicely to a child, but according to the informant, the **child is not expected to know.** The child then uses the plain copula to show that s/he knows.)
- (119) Ciktanpa (Shamskat, Eastern Purikpa, field data 2017)
kho su intsuk? – kho azaŋ / kaka ~ baŋho ~ ataŋho / batse ~ tsetse intsuk.
 s/he who be=GEM – s/he uncle(MB) uncle(FEB) uncle(FYB) be=GEM
 [Adult to child:] ‘Who **is** this? (**The child is expected to know.**)’ – [Child:] ‘He **is** [our] uncle (i.e. mother’s brother / father’s elder brother / father’s younger brother).’
- (120) Lehpa (Kenhat, Central Ladakhi, second generation, field data 2017)
kho / ŋa su inok? – azaŋ / ane inok.
 s/he I who be=GEM uncle(MB) aunt(FS) be=GEM
 ‘Who is s/he / am I? – [S/he] is / [You] are [my/ our] uncle (mother’s brother) / [my/ our] aunt (father’s sister).’ (This way of speaking would be used mainly during the time **when the child has to learn** the relations. When the child has grown up a bit, the plain copula would be used for family relations.)
- (121) Gyaikpa (Kenhat, Upper Indus dialects, field data 2016)
khjoraŋ jīt-u rag-a : ŋa su jīnak. –
 fam.you memory-LOC have.NVIS-QM I who be=GEM
ŋa jīt-u rak : ŋ+e maŋeŋ(-ne) jīnak.
 I memory-LOC have.NVIS I+GEN aunt(MYS)(-TOP) be=GEM
 ‘Do you remember who I **am**? – I **do remember**, you **are** my aunt (mother’s younger sister).’
- (122) Mūtpa (Kenhat, Tibetan border dialect, field data 2018)
kho su jīndak? – aŋe dorze jīndak. –
 s/he who be=GEM elder.brother Dorje be=GEM
ŋa su jīndak? – azaŋ jīndak.
 I who be=GEM uncle(MB) be=GEM
 ‘Who **might** this be? – [He] **is** elder brother Dorje. – Who **might** I be? – [You] **are** [my] uncle (mother’s brother).’ (According to the informant, the use of the GEM is part of a kind of friendly teasing or testing the children, but **one would expect that they know.**)
- (123) Faḍumpa with niece (Kenhat, Central Zanskarpa, field data 2019)
ŋa su ino?, fe-de? – fe, azaŋ ino?
 I who be=GEM know-QM know uncle(MB) be=GEM
 [Uncle:] ‘Who **might** I be? Do you know?’ – [Niece, 8 years, spontaneously:] ‘I **know**, [you] **are** [my] uncle (mother’s brother).’

(124) Pangipa (mixed variety, Himachal enclave, field data 2017)

ŋa su jinne? – *khjo ne ati jinne; ŋa fea.*
 I who be=GEM fam.you we.excl.GEN grandfather be=GEM I know
 ‘Who **might** I be? – You **are** our grandfather; I **know** [well].’

It is certainly possible that this playful questioning *also* serves to teach the children the social relations and the correct use of *inok* & siblings. Interestingly enough, quite a similar usage is found for the marker *red* in Amdo Tibetan, analysed as ‘allophoric’ by Tribur (2019):

(125) Dialect of Gcig.sgril (Amdo; Tribur 2019: 311, ex. 305, glossing adapted)

.ŋe si ret? *ŋa azan ret.*
 I who be.ALLOPHORIC I uncle(MB) be.ALLOPHORIC
 ‘Who **am** I? I **am** Uncle! (Mother’s brother).’

As Tribur comments, the example

was spoken by an adult playing with his newborn nephew. One communicative purpose of the utterance was to model speech for the still pre-verbal infant. The speaker did this by both asking the question and producing the solicited answer himself. The declarative statement is not marked as reported speech—because it isn’t—but its construction is still such as *to express the addressee’s*, rather than the speaker’s, *perspective* on the proposition (Tribur 2019: 311, emphasis added).

One can expect that the play of question and answer would continue when the child is old enough to answer him/herself, and that the child then would likewise use the marker *red*.

3.3.4 Who was it? *Asking about the identity of an absent person (profiling the interests of the person who wants to know)*

When somebody knocks at the door or calls from outside, one must ask the person directly about his or her identity with the plain copula *yin*, and the latter will similarly identify him/herself with the plain copula. By contrast, if a family member goes to look and talk with the person outside, and if s/he comes back without that person, other family members may ask who that person was, using the GEM. The same happens when one receives a phone call, because that person is invisible to the person who wants to know. If the question should target only the addressee’s realisation of the identity of the person in question, then in the case of identifying the person on the phone through his or her voice or because the other person identified him/herself, this would be an identification by sense perception other than vision and the SEM *inɖak*, *inak*, or *jɪn(da)rak* should be used. As this is not the case, the addressee’s way of coming to know is not part of the question. Accordingly, in the case of meeting the person at the door, the question about the latter’s identity is likewise not based on the addressee’s first realisation through visual input.

The question *who was it* thus does not so much reflect the presumed knowledge state of the person who conveys the information, but the knowledge asymmetry between the family member who stayed inside and the one who went to the door and between the one who did not pick up the phone and the one who did. Predictably, the answer to a question like (128), alternative b., concerning an invisible person outside, or to a question like (126), concerning an invisible person on the phone, would then take the same ‘evidential’ form as the question. The GEM is used even when the person is to be identified is a family member of the speaker, see examples (127) to (131). The answer thus profiles the curiosity of the addressee instead of the speaker’s epistemic authority.

- (126) Kargilopa (Western Purikpa, Zemp 2013: 628, no. 84, 2018: 537, no. 648, 555, no. 724)
su in-suk?
 who be-INF/DST (=GEM)⁸³
 ‘Who **was** it (the person you just had on the phone)?’
- (127) a. Mulbekpa (Shamskat, Eastern Purikpa, field data 2016)
su in? – ŋa paldzes in.
 who be.ASS I Paldzes be.ASS
 ‘Who is [it/ this]/ are [you]?’ (Asking from inside a person who knocks at the door, and is thus not visible.) – ‘I am Paldzes.’ (Answering from outside.)
- b. Mulbekpa (Shamskat, Eastern Purikpa, field data 2016)
o: ta su intsuk? – ŋ+i nomo intsuk.
 intj now who be=GEM I+GEN daughter/younger.sister be=GEM
 ‘Now, who **was** [it, at the door]? – [It] **was** my daughter/ younger sister.’ (Somebody knocked at the door, and the first addressee went to look and now is back. [The person (to be) identified remains **invisible** for the first speaker(s) and second addressee(s).])
- (128) a. Sumurpa (Shamskat, Ldumrapa, field data 2016)
su in?
 who be.ASS
 ‘Who are [you]?’ (The speaker hears a person calling from outside and asks the person outside without looking.)
- b. Sumurpa (Shamskat, Ldumrapa, field data 2016)
su intsuk?
 who be=GEM
 ‘Who **was** [it, at the door]?’ (Upon hearing a voice from outside, the addressee went to check and has come back.)
- (129) Tagmacikpa (Shamskat, Western Sham, field data 2022)
 [A:] *aka bos-khan-po / fon joŋ-khan-po su_ intsok? –*
 over.there call-NLS-DF phone come-NLS-DF who be=GEM
 [B:] *anmo intsok. / ama intsok.*
 Angmo be=GEM mother be=GEM
 [A:] ‘Who **was** [the one who was] calling over there? / Who **was** [the one] calling [on] the phone.’ – [B:] ‘It **was** [aunt/ my friend] Angmo. / It **was** [our] mother.’
- (130) Teyapa (Shamskat, Eastern Shamma, field data 2022)
zgo-a rduŋ-khan-po su inok? – aba inok.
 door-ALL knock-NLS-DF who be=GEM father be=GEM
 ‘Who **was** the one who knocked at the door’ – It **was** [my/ our] father.’

⁸³ As far as I know from personal communications, Zemp would insist on a purely inferential value of *-suk*. However, the addressee was certainly not expected to *infer* the identity of the caller. Zemp might further argue that *intsuk* would mark here the projected spontaneously becoming aware of the addressee. However, this is ruled out by the fact that in the other dialects where the auditory inferential is available, the latter is not used, at all.

(131) a. Gya-Mirupa (Kenhat, Upper Indus dialects, field data 2022)

[A:] *su_ _nak, go duŋ-gan-de?* –
 who be=GEM door knock-NLS-DF

[B:] *ŋaʒ·e afo jɪnak.*
 we.incl·GEN elder.brother be=GEM

[A:] ‘Who **was** [the person who was] knocking at the door?’ – [B:] ‘It **was** our elder brother.’

b. Gya-Mirupa (Kenhat, Upper Indus dialects, field data 2022)

[A:] *phun tāŋ-kan su_ _nak?* –
 phone give-NLS who be=GEM

[B:] *afo-se phun lēp-te-inak.*
 elder.brother-ERG phone arrive-LB-GEM=PERF

[A:] ‘Who **was** the person on the phone?’ – [B:] ‘It **was** a phone call by [our] elder brother.’

(132) Faḍumpa (Kenhat, Central Zanskarpa, field data 2022)

[A:] *su_ _inoʔ?* – [B:] *nomo inoʔ.*
 who be=GEM younger.sister/daughter be=GEM

[A:] ‘Who **was/ is** [it, i.e., the person at the door/ on the phone]?’ – [B:] ‘[It] **was/ is** my younger sister/ daughter.’ (The Faḍumpa informant perceives the situation spoken about as still present.)

One can compare this shift of attitude to tense shifts in the Standard European Languages, where the corresponding question likewise refers to the past situation, even though the identity relation would hold on. One could even compare it to the, in the linguistic discussion quite famous, question of the German-speaking waiter: *Wer bekam die Gulaschsuppe?* (lit. ‘Who got the goulash soup?’), uttered while standing there with the soup in his hand.

A related context showed up first in the Faḍumpa dialect. It was confirmed by the Tagmacikpa speaker. According to both speakers, one would use the plain copula when asking about a person that is present (inside the room), but the GEM when asking about an absent person, even if visible from outside. Notably, the GEM would also be used when asking about a person that had been inside after that person has left again. The Tagmacikpa speaker agreed that using the copula in the presence of the person in question is a sign of respect, because if one would use the GEM in her presence, she might get the feeling that she is considered to be nothing or treated like a beggar.

Interestingly, the Tagmacikpa speaker further stated, that when one knows that the person in question, as a foreigner, does not know the language, the GEM could be used neutrally. That seems to indicate that a person who does not know the language (and possibly a deaf person, as well) is communicatively absent. Similarly, when the person is outside the room, even if visible, s/he is communicatively absent, and one can talk about him/her neutrally. In this respect, the choice between the plain copula and the GEM differs considerably from the choice between the copula and the ‘factual’ marker *red* in Standard Spoken Tibetan, where it is the latter that appears to be more respectful, see the discussion following example (2), p. 24.

- (133) Tagmacikpa (Shamskat, Western Sham, field data 2022)

kho su_ _in? / *intsuk.*
 s/he who be.ASS be=GEM

‘Who is/ was s/he (this person present and listening / that person **absent or out of earshot or not understanding**)?’ (When the person is present and understands what you say, then only the copula should be used, as a sign of respect towards this person.)

- (134) Faḍumpa (Kenhat, Central Zanskarpa, field data 2019)

kho su_ (i)no? / *kho su_ _in?*
 s/he who be=GEM she who be.ASS

‘Who was/ is s/he?’ (The GEM is used for **a person who is visible outside**. One may be seeing him/her for the first time or just may not recognise him/her. The plain copula is used when the person is present inside, e.g., one’s brother comes in with a friend whom one does not know yet. If the person was not introduced while s/he was inside, the GEM is the preferred form **when the person has left the room**, independent of whether s/he stays outside for a while, where s/he can be seen, or is gone.)

In the Sankoopā dialect, a speaker would likewise ask about a person outside with *intsuk* and the addressee would answer accordingly, even when talking about a person s/he knows well. All further descriptions would then trigger the use of the Set I markers.

- (135) Sankoopā (Southern Purikpa, field data 2022)

ataama-s: «*a mi-u su in-tasuk?*» –
 father.mother-ERG that person-DF who be-INF/DST(=GEM)

husseyn-is: «*η+i rgakhan in-tasuk. kho master in.*»
 Husseyn-ERG I·GEN friend be-INF/DST(=GEM) s/he teacher be.ASS

‘The parents: «Who **is** that person (outside)?» – Husseyn: «[He] **is** my friend. He is a teacher.» (Husseyn and his parents talk about a person visible through the window.)

In the Mulbekpa dialect, spatial distance appears to play an even greater role beyond these questions. According to the informant, one would use the plain copula, when introducing a well-known person of one’s cultural sphere to the addressee. However, when talking about the same person when s/he is absent, one would use the GEM. As in the other cases, the GEM does not, in this context, indicate an inference or a sudden realisation upon seeing, but highlights a certain mental distance that has been increased through the spatial distance.

- (136) Mulbekpa (Shamskat, Eastern Purikpa, field data 2018)

sonam ŋaŋ+i jul-i goba in. / *intsuk.*
 Sonam we.excl·GEN village-GEN village.head be.ASS be=GEM

‘Sonam is the head of our village.’ (The plain copula is used when the person talked about is present; the GEM is used **when s/he is absent**.)

Note also example (112) above from the Lehpa dialect, where the plain copula *yin* is used for introducing a friend present (if only on a visual representation), while the GEM is used when that person is absent. Presence and absence of a person talked about plays a similar role in Denjongke, see Yliniemi (2019: 260, 273f. with exx. 7.49-7.51).

The question how identifications interact with (in)visibility or distance of the item in question and perhaps also how this interaction depends on the speaker’s relationship towards the item

in question *and* his/her relationship towards the addressee certainly needs further research. For a possible much older usage of the combination *yin & hdug* in a similar context, see also example (231) section 4.2 below.

3.3.5 It's your own fault and you know it (*profiling the addressee's expectable knowledge*)

When one is responsible, through carelessness or stupidity, for a loss or for being scolded badly or even being beaten up, people throughout Ladakh use the collocation 'you bought it (yourself)' to indicate 'it is your own fault'. When blaming the addressee, an emphatic past tense or a perfect construction are commonly found. The emphatic past tense (verb stem plus emphatic marker {*pa*}) is particularly used when the person had acted against one's explicit advice. The perfect construction combines either with the plain copula or with the GEM. The choice depends on whether it is just a subjective evaluation of the situation, whether the addressee has acted against the advice of the speaker (in both cases the plain copula is used), or whether the addressee could have known better by him/herself, particularly in cases, where the negative outcome is more widely known, such as giving away one's account number, not buying a full insurance for the new car, stealing, and the like. The GEM thus lays the focus not on the speaker's knowledge, but shifts it on the potential knowledge of the addressee and on what is generally known.

(137) a. Tagmacikpa (Shamskat, Western Shamma, field data 2022)

ŋ·i dzamo aŋoz-la khora+(·) soŋ, abaama+(·) ma-ŋi-a.
 I+GEN friend.fem other.side-ALL tour-ALL go.PA father.mother-ALL NG-ask-NLS
detsana ŋa-s kho-a «abaama+(·) tis!» ze:s-pin.
 that.time I-ERG s/he-ALL father.mother+ALL ask.IMP say.PA-RM=ASS.PA
ta daksa kho lok-se-joŋ-se-na-ŋ, sanŋe gjot-e-nok, (!)
 now now s/he return-LB-come-LB-ABL+FM very repent-LB+GEM(Leh-type)=PERF
abaama[-s] kho-a kharul maŋbo taŋ-sok.
 father.mother-ERG s/he-ALL bad.scolding much give-INF/DST
deana ŋa-s ze:s-pin : «d-o kheraŋ-is nos-e-in,
 then I-ERG say.PA-RM=ASS.PA that-DF fam.you-ERG buy-LB-CP=ASS.PERF
abaama+(·) ma-ŋri-a soŋ.»
 father.mother-ALL NG-ask-NLS go.PA

'My (female) friend had gone on a tour abroad (lit. to the other side), that is, without asking [her] parents. At that time, I had told [her]: «Ask your parents [before you go]!» Now, after she came back, she apparently repents [her behaviour] a lot, because [her] parents were scolding her badly. Then I said [to her]: «That is your own fault [as I had told you]: you went without asking your parents [against my advice.]»' (The speaker focuses on his/her personal assessment of the situation, based on his/her earlier advice.)

b. Tagmacikpa (Shamskat, Western Shamma, field data 2022)

ŋ·i dzamo-s restoren sul-ba+(·) gormen-i bulon maŋb-ek khjoŋs.
 I+GEN friend-ERG restaurant drive-NLS+ALL government-GEN loan much+LQ bring.PA
ta daksa restoren-bo gjala ma-nqul,
 now now restaurant-DF good NG-go=PA
bulon kok-ŋfaz-la kaksपो ifhe-en-uk.
 loan repay-GRD-ALL difficult go-CNT-VIS=PRS

deana ŋa-s ze:s-pin : «d-u kheraŋ-is no-se-intsok,
 then I-ERG say.PA-RM=ASS.PA this+DF fam.you-ERG buy-LB-GEM=PERF
restoren-tsak maŋb-ek ma-ndul-a-intsok, le market-la.»
 restaurant-PL much+LQ NG-go-NLS-GEM=PERF Leh market-ALL

‘My (female) friend had taken a government loan in order to run a restaurant. Now, the restaurant did not go well. [And] it was/ is getting difficult [for her] to repay the loan. Then I said [to her]: «This is **your own fault** [and you could have known better]: (as everybody knows,) the restaurants are not doing well (lit. restaurants have not been/ are not going much), that is, those at the Leh bazaar.»’ (The speaker **defocuses from his/her own knowledge** and focuses on what the addressee could have known and on what is generally known.)

- (138) a. Gya-Mirupa (Kenhat, Upper Indus dialects, field data 2007)

meme-se «rama+(.) ma-ŋha-raŋ!» zer-in, kho, raŋgal tā-re, soŋ.
 grandfather-ERG goat+ALL NG-go=PRHB-DM say-CNT s/he insistence give+LB go.PA
hinaŋ ŋima+(.) rama+(.) ŋaŋgu ŋu(ŋ). tene kho ŋante dʒik.
 but sun+ALL goat+ALL wolf appear=PA then s/he very be.afraid=PA
tene phitok meme-se zer :
 then evening grandfather-ERG say=PA

«ŋ-e <ma-ŋha-raŋ!> zer-e-in; (tere) khjoraŋ-e ne-fa!»

I+ERG NG-go=PRHB-DM say-LB-CP=ASS.PERF (intj) fam.you.self-ERG buy=PA-emp

‘The grandfather had been saying: «Don’t go with (lit: for) the goats!», but getting his/her own way, s/he went [with the goats]. But in the [bright] sun, a wolf came over the goats. S/he was terribly afraid. Then, in the evening, the grandfather said: «I had told [you] <not to go>. (See,) now you have the result! / [That] will teach you!»’

- b. Gya-Mirupa (Kenhat, Upper Indus dialects, field data 2022)

te khjore ne-re-in. / ne-fa!
 that fam.you.self-ERG buy-LB-CP=ASS.PERF buy=PA-emp

«khimtsep-e khi+a ma-dan!» ze:-fa, dan-pa, ta taksa tham.

neighbour+GEN dog-ALL NG-tease=PRHB say-NLS tease-NLS now now bite=PA

‘This serves you right! [I/ We] told [you] <not to tease the neighbours’ dog>, [you] did it [right away], so now [you] were bitten.’

- c. Gya-Mirupa (Kenhat, Upper Indus dialects, field data 2022)

khjoraŋ-gun ne-re-in. thabdiŋ tā-re, nēka+(.) phok.

fam.you-PL buy-LB-CP=ASS.PERF fighting give+LB both-ALL be.hit=PA

‘It’s just you guys’ own fault (I think). Fighting each other, you both got hurt.’

- d. Gya-Mirupa (Kenhat, Upper Indus dialects, field data 2022)

ta khjore ne-re-inak. galđi rintfan ne-re, infurens mā-ŋe-fa,

now fam.you.self-ERG buy-LB-GEM=PERF car expensive buy-LB insurance NG-do-NLS

ta dan egziden so-re, galđi tshettshet so-rok.

now yesterday accident happen-LB car demolished happen+PA-INF

‘Now, there’s **nobody to blame other than you** (and you know it). [You] bought an expensive car, but did not contract an insurance, and so yesterday there was an accident, and [your] car got demolished.’

On my last day in Leh in 2022, I had the opportunity to casually talk about this usage with Rebecca Norman, who has been living in Ladakh since three decades, and with the Faḍumpa speaker. While the latter, at first, could not figure out the difference between the perfect with the plain copula and the perfect with the GEM, Rebecca Norman correctly assumed that the plain copula would be used when the addressee acted against one's advice (implying that there has not been any such advice when the perfect with the GEM is used). When offered a context where somebody went trekking without taking sunglasses, sun milk, or gloves, and without having been warned against doing so, and then suffered sunburn or frozen fingers, both Rebecca Norman and the Faḍumpa speaker agreed on the use of the GEM.

3.3.6 It's mine, not yours (*profiling the addressee's relationship – to one's own items*)

When somebody takes my bag and I know well that it is my bag, then I know equally well that it is not the bag of that particular somebody. One would expect that if the speaker can use the assertive copula for stating that a certain item (or also task) is his/her own, then s/he should be equally licensed to use the assertive copula when stating that it is not the addressee's. However, many speakers confirmed that they would switch between the copula, when talking about an item as belonging to them and the GEM when talking about the same item as not belonging to the addressee.

(139) Ralepa (Kenhat, field data 2023)

ʃiŋ! *ʃiŋ!* *tɛ* *ɖzola* *niri* *m̄ndak.* / **man.*
 wait=IMP wait=IMP that bag fam.you.GEN NG.be=GEM *NG.be.ASS
ŋ·e / *ŋ·e* *māk̄p·e* *hin.* / **hindak.*
 I+GEN I+GEN husband+GEN be.ASS *be=GEM

'Wait, wait! That bag **might not be** / *is definitely not yours. [It] is definitely / *might be mine. / my husband's.'

I have used a modal expression in the translation to show the, from our perspective, oddness of the switch. The modal expression does not really fit, as the GEM does not express any epistemic hedging. It is not that the speaker has any doubts. What the speaker indicates here is that the belongings or not-belongings of the addressee do not fall into the speaker's territory of information. One could take the GEM and the modal in the translation as expressing pragmatic hedging for the sake of politeness. However, one would then expect that the speaker would keep this moderate tone also for stating his/her ownership rights. But this is not possible for a Ladakhi speaker.

The main point in the above example is that the speaker, so to speak, is not responsible for the fact that the addressee is not the owner. There are, of course, also contexts, where the speaker is responsible for the item in question, e.g., when having exchanged the relative position of two similar items unbeknownst of the addressee, when having kept and deposited certain items for the addressee, or when having assigned a particular task. In such cases, the speaker will use the assertive copula when indicating that the item (or task) in question is or is not the addressee's.

The effect does not depend on the order of the positive and the negative statements. The effect has been confirmed by speakers of the Kenhat dialects of Leh (negated GEM: *manok*), Gya-Miru (negated GEM: *manak*), and Faḍum (negated GEM: *mano*[?]), and by a speaker of the eastern Shamma dialect of Teya (negated GEM: *manok*). By contrast, one speaker of the Southern Shamma dialect of Lingshet denied that he would switch; he would use only the copula *yin* for stating both his own and the addressee's (non)-possession. Unfortunately, no data is yet available from speakers of Western Shamma dialects for this particular context; however, the same effect has been observed

for statements about *my but not your job/ task*. Two speakers of the Purikpa dialects of Sapi and Ichu have likewise confirmed the switch between the negated GEM *mantsuk* for the addressee and the copula *yin* for themselves, but given the casual setting in which I obtained their answers, I cannot preclude misunderstandings on either side.

3.3.7 *Expressing one's feeling of shyness or shame (profiling the addressee as being more competent or projecting the addressee as being much richer)*

Bielmeier (2000) mentions the use of *inok* for self-identification, motivated by what he takes to be politeness, (140). However, all informants with whom I discussed this usage have either rejected it or described it rather as an utterance of shyness or shame. In the case of example (140), the speaker would be shy or would feel ashamed, because being a trader is not such a great thing as compared to teachers, doctors, or engineers. One becomes trader only when one does not have other options. This usage is attested around the ancient royal centres in Leh and Shey, to some extent also in some of the eastern regions, but is absent in the periphery, especially the western regions.

(140) Nurlapa (Shamskat, Eastern Shamma, adapted from Bielmeier 2000: 95, no. 65)

ŋa tshoŋpa inok.

I trader be=GEM

'I am (only) a trader.'

(141) Stokpa (Kenhat, Central Ladakhi) *Kesar* (recorded 1996)

ŋa+(.) dontaŋ phul-ŋe met. abi gatmo-zik inok.

I+AES meal offer-NLS have.ASS grandmother old-LQ be=GEM

'I don't have any food to offer [you] (I can assure you). [I] am only an old grandmother (and I feel shame/ shy/ insignificant/...).'

(142) Chushulpa (Kenhat, Lalokpa, field data 2016)

ŋa taruaŋ lōptuk-ŋik hinak-pa, thel-te ŋi-a-rak.

I still student-LQ be=GEM-emp be.ashamed-LB die-NLS-NVIS=PRS

'I am (unfortunately) still (only) a student. I'm so ashamed, I'm going to die.'

In the above example, the second clause was added upon my suggestion, in order to make the connotation of regret and shame of the first clause explicit and to further emphasise it. This second part is by no means necessary for the interpretation of the first part. Likewise, the emphatic marker *pa* merely stresses the emotional involvement, but otherwise does not add to the meaning of regret or shame.

(143) Çarapa (Kenhat, Upper Indus dialects, field data 2016)

ŋa zara hinak.

I blind be=GEM

ŋ+e dzamo-aŋ zara hinak. kho dgarmani-ne hinak.

I+GEN friend.fem-FM blind be=GEM s/he Germany-ABL be=GEM

'(Embarrassingly,) I am blind (as you must know). My friend is also blind (you might not know). She is from Germany (you might not know).'

(The speaker does not know that the addressee, BZ, actually knows her friend.)

In the last example, there might be two motivations for the use of the GEM in the first part. Everybody who has seen the speaker will know that she is blind; it is thus not exclusive personal

knowledge. The speaker, however, confirmed in 2017 that the GEM can be used in her dialect to express one's sense of inferiority, e.g., to say that one is a person without education, cf. her example (144), alternative a, which was not further discussed. By contrast, the GEM could not be used when one introduces oneself as a teacher, something one can be proud about, (144), alternative b. The GEM may thus signal that one does not fully identify with one's role in the society or, in the case of impairment, not with one's fate.

(144) a. Çarapa (Kenhat, Upper Indus dialects, field data 2016)

ŋa jontan meṭ-kan-e pɔmo hinak.
 I education NG.have-NLS-GEN girl/woman be=GEM

'I **am (unfortunately/ only)** a woman without education.' (The speaker feels shy or ashamed.)

b. Çarapa (Kenhat, Upper Indus dialects, field data 2017)

*ŋa lū lāp-kan-dzik hin. / *hinak.*
 I song teach-NLS-LQ be.ASS *be=GEM

'I teach songs (lit. I am a song teacher) (and I am kind of proud about it).'

Rev1 suggests to analyse the element *-ok/-ak* of the GEM as a marker of visual access, which would yield an identification from an outside perspective. However, this would most likely yield the connotation *I just see / find out/ realise that I am a trader, etc.*, something a person with partial amnesia might perhaps say. The 'outside perspective' of mental non-identification with one's role or fate, however, has a different connotation: *I may be a trader, etc., but this has not much to do with me/ with my wishes*, and this connotation has become independent from the question of access.

In 2019, the Faḍumpa informant rejected the use of the GEM for such feeling of inferiority. Nevertheless, I have come across two examples of an apparently related usage in the dialect of the close-by village Karsha. The first occurs in a video recorded by Maaz Shaikh, University of Alberta, where one of the two ladies interviewed remarks:

(145) Karshapa (Central Zanskar, Kenhat), interview by Maaz Shaikh 2022

goma:(.) nalbatfan _no?, mi tshamma, ...
 beginning+ALL poor be=GEM people all

'In the beginning, [we] **were just** poor, all the people, ...'

Part of the motivation for the GEM is that this is shared knowledge among the speech community. The speaker does not talk about her own status or perception of being poor, but refers to all the people including her: *the people (that is, we all,) were poor in the past*. This interpretation was also suggested by the Faḍumpa speaker in 2022. However, the statement also seems to be a kind of standard complaint (besides the complaint that in the past, most things social were much better), a complaint that comes up naturally, when talking to foreigners (including Indians), who are conceived as being rich by definition. The utterance is thus perhaps not to be taken too seriously. To catch this notion, I would insert the particle *halt* or *eben* in the sense of 'just' and 'nothing special' in a German translation.

The same connotation shows up in the utterance of an old abbess in the Arte documentation *Zanskar – Die Versprechen des Winters/Zanskar, les promesses de l'hiver* (Zanskar, the promises of winter) by Caroline Riegel, 16.12.2021. Unfortunately, the voice-over translation covers up most utterances,

so that very few original sentences can be heard. The old abbess talks about her three blankets, two of which were given to her, the third being patchwork, and comments:

(146) *abi* Pele, Karsha (Central Zanskar, Kenhat, video 2021)

ta awi nalbatfē_ 'no'?
 now grandmother poor be=GEM
 'So then, [I] **am just** a poor old woman.'

In this case, the statement is only about the speaker and how she perceives herself, possibly in contrast to the French filmmaker. The speaker apparently also declares herself as stupid (according to the translation), making herself smaller or less significant than she is, and the filmmaker then promptly asks her not to say such things.

In 2023, when discussing the topic again, the Faḍumpa informant stated that the expression *nalwatfen no'* '[I/ we] am/ are poor' may be used, when apologising to a visitor that one cannot offer very tasty food (as might be expected) or that the carpet is worn, etc. There may be a connotation of 'as you can see'. At the same time, one may see this as an attempt to prevent criticism (behind one's back) by appealing to the addressee's mercy. With respect to usages as in examples (140) and (143), the Faḍumpa speaker commented in 2023 that, depending on the situation, such statements might be marginally possible, but most people (in Central Zanskar) would possibly reject them. – It is well possible, that his statement reflects a different self-perception of male and female speakers.

3.3.8 Lowering oneself in sarcastic usage (pretending to profile the addressee as being more competent)

The GEM may be used in sarcastic speech, besides, or in place of, the 'of course'-marker *-k(h)anla*. Both markers may be used to express one's annoyance in view of being criticised. The speaker then virtually lowers him- or herself down and pretends to be less skilled etc. than s/he is. In this context, the GEM is found even with speakers of those dialects, where the GEM is not normally used to express one's feeling of shame, e.g., in the Tagmacikpa dialect, (147).

(147) Tagmacikpa (Shamskat, Western Shamma, field data 2019)

[A:] *kheraŋ-a eplikefen ffig-aŋ bri-a-ŋen-ba-mi-nuk!* –
 fam.you-AES application one-FM write-NLS-be.able-NLS-NG-VIS=PRS
 [B:] *ona, ... ŋa fi-aŋ takp+ek mentsok-pa. / men-khanla.*
 intj I what-FM great+LQ NG.be=GEM-emp NG.be-of.course

[A:] 'You can't even write an application!' – [B:] 'Oh yes, ... (unlike you) I **am not** at all that great (implied: there are many more persons greater than me). / of course, I am not at all that great (quite as you expect).' (In both cases, speaker B is offended by the criticism and answers with sarcasm. The first alternative with the GEM hits more indirectly at the addressee as one of those who think big of themselves. / The second alternative is more directly turned against the criticism.)

When re-discussing the example in 2022, the informant stated that the marker *-khanla* is ambivalent between a true statement about a fact also known by the addressee and a sarcastic utterance. The GEM, by contrast, indicates more directly that the statement cannot be true. Here, both markers are used in a sarcastic manner.

In (148) from the Kesar epos, the narrated speaker is a trickster figure, who, particularly in his youth, hides his divine nature under the disguise of an ugly and, in the eyes of his contemporaries,

illegitimate child. He is deprived of his heritage, a fact about which he complains, presenting it as if just becoming aware of it. While complaining, he talks about himself as a despicable person, sarcastically and as a challenge.

(148) Stokpa (Kenhat, Central Ladakhi), *Kesar* (recorded 1996)

ta *ŋa-nik* *ama* *Gogza* *Lam·e* *thugu*,
now I-TOP mother Gogza Lamo·GEN child

mōan-i *ṣaŋthuk* *inok*.
woman.bad-GEN street.child be=GEM

ŋa+(·) *ʃig-ek* *mane* *mi-rak*.

I+AES one-LQ ever NG-have.NVIS

ŋaza+(·) *mane* *sakjat* *mane* *mi-ruk*. ...

we.excl+AES ever land ever NG-have.VIS

neza-s ... *tene* *ŋa+(·)-aŋ* *sakjat-ʃik* *sal-gos-ok!*

you(excl)-ERG then I+ALL-FM land-LQ hon.give-need-INF.FUT

‘Now, as for me, I **am just** mother Gogza Lhamo’s child, **just** a street child, born to a despicable mother. *To my dismay*, I do not possess a single thing (on my body), at all! *To our dismay*, we [mother and I] do not have any land, at all! ... You guys ... have to give me a piece of land!’

In 2019, the Faḍumpa speaker suggested that the use of the GEM for oneself might indicate that one is not speaking seriously. If he wanted to excuse himself for not being able to give a donation because he were really poor, he could not use the GEM. But to say that one is poor and at the same time indicate that one is not really poor can be seen as a reaction of defiance, comparable also to the usages described in the next section.

(149) a. Faḍumpa (Kenhat, Central Zanskarpa, field data 2019)

ŋaza+(·) *tanju* *met*, *nalbaŋfen* *hin*. / *hino?*

we+AES give.means NG.have.ASS poor be.ASS be=GEM

‘We have nothing to give; [we] are (really / **just**) poor people.’ (Reacting to a request for a donation or to critical comments upon one’s stinginess. The use of the GEM indicates that one is not speaking seriously, but rather sarcastically. The speaker is *not* poor.)

b. Faḍumpa (Kenhat, Central Zanskarpa, field data 2019)

gōfa *sal*, *ḍudḍu!* *ŋaza+(·)* *tanju* *met*, *nalbaŋfen* *hin*. / **hino?*

excuse hon.give please we+AES give.means NG.have.ASS poor be.ASS *be=GEM

‘Please, forgive [us], we have nothing to donate, [we] are (really) poor people.’ (The GEM is not possible when talking seriously and feeling shame.)⁸⁴

This kind of non-serious talk may possibly have a parallel in Lhasa Tibetan. Oisel (2017: 116) mentions the use of ‘factual’ *red* for non-serious speech or joking, here in a future tense construction.

⁸⁴ The motivations for using the GEM for oneself may differ considerably between the dialects. As mentioned above, the GEM can be used in the central dialects when feeling ashamed, but this is impossible for speakers from Western Sham, not to speak of Purik, and it appears to be uncommon for the Faḍumpa speaker, even in view of examples (145) and (146) from a nearby village. There is certainly also some individual variation, possibly also between male and female speakers.

(150) Lhasa Tibetan (Oisel 2017: 116f., ex. 79, transliteration adapted)

[The man:] *kūci?*, *kūci?*, *ŋa* *ŋotsa-ki?* –
 please please I be.ashamed-ENDOPATHIC.‘IMPERFECTIVE’

[The woman:] *raŋ* *ŋa+*: *o* *ma-kjē:-na*
 you I+ALL kiss NG-deliver-CD

ŋ+ε? *lōkɛu* *pār-kire?* *hā!* *hā!*
 I+ERG light turn.on-FACTUAL.FUTURE ha ha

[The man:] ‘Please! Please! I’m ashamed. (Don’t switch on the light!)’ – [The woman:] ‘If you don’t kiss me, I **will turn on** the light. Ha! Ha!’

3.3.9 Other usages concerning the speaker, carrying a special emotional load

The GEM may also be used by some speakers for the first person with the aim to impress or frighten the addressee. This usage stands in opposition to the otherwise more deferential use of the GEM. I suppose this marked meaning results from the contrast with what is expected to be used for the first person. According to the Faɽumpa informant, one motivation is also just to make the addressee aware. However, the speaker would also distance him/herself from him/herself, and by this attitude create a negative or positive connotation. Examples (151) and (152) are uttered as a warning, but with a certain emphasis, underlined through the emphatic marker. In (151), the speaker expects the addressee to already know what kind of person he, the speaker is. In (152), the speaker describes herself. The GEM may also indicate some sort of pride or also a reaction of defiance, (153). Cf. also section 3.4.7 for similar usages with the most neutral DEPERSONALISED GENERIC KNOWLEDGE MARKER (DPG).

(151) Sankoopa (Southern Purikpa, field data 2022)

ŋa *su* *intsuk* *kheraŋ-a* *pata* *jot-a?!*
 I who be=GEM fam.you-AES knowledge have.ASS-QM

ŋa-s *kherang-a* *rduŋ-e(n)-nuk!*
 I-ERG fam.you-ALL beat-CNT-EXP=PRS/FUT

‘You do know who I am, right? (So **be warned**.) [You’ll see how] I’ll beat you up!’

(152) Rumbakpa (Kenhat, Central Ladakhi, field data 2017)

kheraŋ *izuk* *ʃo-na*, *ŋa-ni* *ma:* *sokpo* *inok* *he!*
 fam.you this.way do-CD I-TOP very bad be=GEM intj

‘If you act like this, (**be warned**) I can be quite nasty!’

(153) a. Faɽumpa (Kenhat, Central Zanskarpa, field data 2023)

ŋa *fon* *fino²-pe!*
 I painter be=GEM-emp

‘I am a painter (of religious figures) (**isn’t that something**)?! (But the speaker is not a real painter!)⁸⁵

⁸⁵ Nicolas Tournadre (p.c., May 2023), pointed to a similar sentence in the Leh dialect. According to him, *inok* would generally express a speaker’s heightened authority. However, this is certainly not true for the most common usages of *inok* & siblings, and it is not even true in the above context. In any case, examples like the above one are marginal and cannot be taken for the core meaning of the form.

b. Faḍumpa (Kenhat, Central Zanskarpa, field data 2023)

ʃhu'po ino'-pe te!

rich be=GEM-emp then

‘[I]’m rich (enough), **so what?!**’ (This might be said as a reaction upon being criticised for spending a lot of money.)

Potentially parallel usages of the copula *red* and of the existential *yod.red* for the speaker in assertions are described by Oisel (2017: 109) as emphatic assertion. Example (154) is described as provocative statement, focussing on the dangerousness of the act, since going to Dharamsala was forbidden at that time. In example (155), the speaker insists on the fact of not having married, either confirming a question or countering a statement of disbelief. The situation may not be fully acceptable for the addressee or the larger community (or the state).

(154) Lhasa Tibetan (Oisel 2017: 109, ex. 53, transliteration and translation adapted)

lo 1998 ŋa daramsala-la tɛh[ɪ]n⁸⁶-pare?

year 1998 I Dharamsala-ALL go.PA-FACTUAL.PAST

‘I went to Dharamsala in 1998. [**I took the risk**, as it was forbidden].’

(155) Lhasa Tibetan (Oisel 2017: 109, ex. 55, transliteration and translation adapted)

re? ŋaŋi? ʃhāŋsa kjaŋ-jo:mare?

be.FACTUAL we.two marriage VERBALISER.PA-NG.FACTUAL.PERFECT

‘Correct! We aren’t married [**as you assume/ believe it or not**].’

3.4 Generalised or ‘factual’ usage

I must confess that I have some problems with the notion of ‘factual’ in connection with the ‘evidential’ systems of the Tibetic languages. As Suzuki, Sonam Wangmo, & Tsering Samdrup (2021: 75) remark: “[s]everal terms refer to the factual/statemental category; however, there have not been any debates over which terms are exclusive and more suitable for the category.” What is likewise missing is a debate about how useful the category ‘factual’ or ‘statemental’ or also ‘assertive’ is for the Tibetic languages.

From a cross-linguistic perspective, ‘factual’ may be opposed to ‘irrealis’ mood (see, e.g., Tantucci 2016: 183; cf. also Tribur 2019: 113, Table 12, repeated p. 249). In a somewhat narrower sense, it may also be opposed to evidential marking in the strict sense, that is to – external – ‘direct’/sense perception and ‘indirect’/inference/hearsay (see Kittilä 2019: 1275, 1297f.; Tribur 2019: 113, Table 12, repeated p. 249, and *passim*). In accordance with this view, Zemp (2018) uses the term ‘factual’ for all forms based on *yod*, because in the Kargilopa dialect, they are opposed to the experiential (in his terminology ‘testimonial’) marker *hdug*. The copula *yin*, on the other hand, is not described as ‘factual’, apparently because it would lack an experiential counterpart. I should think that Zemp’s use of ‘factual’ is quite suitable for both Set 1 markers, *yin* and *yod*, in the Baltipa dialects of the Turtuk area, the Southern and Western Purikpa dialects, and to some extent also in the Eastern Purikpa dialects.

In most descriptions of the Central and Eastern Tibetic languages, it is neither *yod* nor *yin*, which are described as ‘factual’, but *red* and *yod.red* and the respective counterparts. These markers

⁸⁶ Throughout his article, Oisel transcribes this verb with low tone: “chɪn”. However, given the written form *phyin*, the verb should have high tone; and it is listed with high tone in Bielmeyer & al. (2018: 208b).

are described as presenting facts without indicating the particular source or access channel or, in other words, “with the information-source left unexpressed” (Sun 1993: 950f.), being “unmarked for evidentiality” (Sun 1993: 951), “non-evidential” (Tribur 2017: 373) or “evidentially-neutral” (Tribur 2017: 375). However, as Kittilä (2019: 1293) has shown, ‘factual’ or alternatively ‘general’ knowledge comprises most particularly *also* one’s privileged personal access, and would thus yield ‘egophoric’ or Set 1 markers in the Tibetic languages. As a result, the Tibetic languages would have two sets of ‘evidentially-neutral’ (i.e., non-experiential/ non-testimonial) markers. The ‘factual’ or non-experiential character of the Set 1 (or ‘egophoric’) markers is quite likely the reason why Aikhenvald and in principle also DeLancey do not include these markers in the category of evidential markers in the strict sense. According to Aikhenvald, the main system is a kind of weird person-marking system, treated under the terminology of ‘conjunct-disjunct’, and “the ‘true’ evidentiality system (first-hand versus non-first-hand [i.e., inference!]) is only found in perfective” or, to be precise: with perfect constructions (Aikhenvald 2004: 264, based on DeLancey 1986: 210f.).

What I shall describe below, has, in fact, less to do with sources and access channels, but with what has also been described as ‘epistemic authority’ and ‘right to know’ (Grzech 2020; cf. also Aikhenvald 2018: 29), ‘territories of knowledge’ (Kamio 1997, Heritage 2012), ‘mutual knowledge’ (Hintz & Hintz 2014/2017), or ‘engagement’ (Bergqvist & Kittilä 2020), namely the question of speaker-hearer (a)symmetries and the pragmatic handling of these in the communicative situation. Additionally, it has to do with knowledge shared by a third party collective. According to Tantucci (2013: 224), in such cases, “the proposition is ‘presented’ as a shared knowledge and not ‘asserted’ as a subjective proposition personally believed by the SP/W [speaker/writer]”.

However, if one classifies the pragmatically conditioned choices of *inok* & siblings as ‘non-evidential’, then the whole system becomes ‘non-evidential’. In terms of ‘evidentiality’ (in a broader sense) as a grammatical means to specify different knowledge *types*, generic or shared knowledge can be classified as non-personal knowledge in contrast to the knowledge acquired through personal involvement, personal observation, or personal inference or assumption.

It should be noted that the GEM is not the only marker for generic facts, but competes with other markers, such as a neutral future tense construction (V-GRD-*yin*) or the Kenhat future inferential *-ka(na)k* or also the assertive and perceptual markers when used for habits. While these latter markers put the focus on one’s access channels or one’s private sphere (or territory of knowledge), the GEM shifts the focus on the addressee’s knowledge or, in the case of his/her lack of knowledge, on his/her interests or obligations to know.

3.4.1 *Shared observations (defocusing from one’s personal observation)*

Since the visual marker goes along with the connotation of a personal or private observation, it is for many speakers not suitable in a situation where both, speaker and addressee(s) observe the situation together (and when it is thus not necessary to draw the attention of the addressee(s) to a particular situation or fact). Despite Anderson’s (1986: 277) early observation that evidentials are rarely used when the situation is directly observed or observable by both speaker and addressee, very few scholars in the field of Tibeto-linguistics have commented upon the use or non-use of the experiential or visual marker when speaker and addressee both observe the result together or when the speaker can assume that the addressee has observed it as well. With respect to the South Tibetan language Denjongke, Yliniemi (2019: 259) states:

[The neutral copula *be?* (<*sbad*)] can be used, for instance, when the speaker and the addressee share the same visual experience at the moment of speech, and, therefore, it would be redundant for the speaker to use an evidential to make explicit how the information was received. [...] The term “neutral” [...] derives from the Denjongke system where neutrality is defined as absence of sensorialness and personalness.

With respect to his examples 7.53a and 7.53b, which show the use of *be?* and *du?* respectively, Yliniemi (2019: 275) further states

One context for saying (7.53a) [with *be?*] rather than (7.53b) [with *du?*] is when the sensory experience [for] the knowledge acquired is shared by the speaker and the addressee. In these cases, there is no need to base one’s assertion [on] an evidential.

With respect to West Tibetan, Jones (2009) and Zeisler (2018a: 96) point to the possible use of the non-experiential marker *yod* in such situations. This option is attested so far only in some Baltipa and some Western Shamma dialects. It is not available in the Kenhat dialects nor in the Purikpa dialect of Ciktan. There are various other strategies to avoid the visual marker, but more research is necessary to get the whole picture. One such strategy, comparable to that in Denjongke, involves the use of the GEM. Unfortunately, this usage has been fully understood only during the last field stay before the Corona pandemic struck, in 2019. Therefore, only few data are available. Nevertheless, they indicate that the strategy may be used across the dialect divide, even if the motivations may differ somewhat.

- (156) Anonymous (Lehpa, Kenhat / Western Shamma, Shamskat, 2014, overheard)
kho fhirgjalpa inok! ~ intsok!
 s/he foreigner be=GEM(Lehpa) be=GEM(Shamma)
 ‘[But] she **is** (apparently/ surprisingly/ **as we see**) a foreigner!’

In this situation, first a family in a car, somewhat later two ladies from the Brokpa community of Lower Ladakh commented upon BZ who, despite being a foreigner, was wearing the traditional Ladakhi coat. There was thus a connotation of surprise in both statements. However, in this case of shared visual observation, the visual marker is not possible.

- (157) Ciktanpa (Shamskat, Eastern Purikpa, field data 2017)
dun-p+ika roa?-po duk. / dun-po roa? intsuk.
 front-DF+PPOS road-DF exist.VIS front-DF road be=GEM
 ‘In the front [of this photograph], there is a road (have a look at it). / That in the front **is** a road (as you can also see).’ (The visual marker implies that the addressee is not looking at the photograph or not paying attention to the road. / The GEM implies that speaker and addressee are looking together at the photograph and commenting upon what they see.)

A perfect construction with the GEM is used for shared observations of results, (158)–(162), but also for ongoing situations observed together with, or observable for, the addressee, (163).

- (158) Tagmacikpa (Shamskat, Western Shamma, field data 2019)
ŋa tsuntse men, ŋa-(:) sul marbo du-se-jot. / du-se-intsok.
 I small NG.be.ASS I+AES wrinkle many gather-LB-EX=ASS.PERF gather-LB-GEM=PERF
 ‘I am no longer young; there are (lit. have gathered) so many wrinkles (as I know for a while / **as you can see** [so please stop making false compliments]).’

This usage also applies to observations of which one assumes that the addressee made them already independently, e.g., when one knows that the addressee has come along the same harvested field. Otherwise, if one thinks that one is telling some news, the visual marker would be used.

(159) Tagmacikpa (Shamskat, Western Shamma, field data 2019)

khon-is zih ŋŋa-se-intsok. / *ŋŋa-se-duk.*
 they-ERG field harvest-LB-GEM=PERF harvest-LB-VIS=PERF

‘(Apparently,) they have harvested the field(s) (**as you can see** / have a look).’ Or:

‘(Apparently,) they have harvested the field(s) (**as you might already know**, since you also came along that way / as I just saw on the way).’

The perfect construction with the GEM remains ambiguous between an inferential reading and the downgrading of one’s personal observation when talking to the addressee in view of the situation.

(160) Tagmacikpa (Shamskat, Western Shamma, field data 2019)

tshas-la fhu taj-tsana,
 garden-ALL water give-when
kho-s ŋi nan-a+ŋ fhu ŋtat-e-intsok, lta-ma-lta-a.
 s/he-ERG I+GEN house-ALL+FM water let.go-LB-GEM=PERF look-NG-look-NLS

‘While watering the garden, s/he **let** the water **flow** also into my house, without looking at all (**as I can infer** from the water everywhere // **as you see**).’

In the Faɖumpa dialect, one can observe a similar downgrading of one’s personal observation and prior knowledge, albeit for quite different reasons. When telling back home what one has done, the Faɖumpa speaker would use the perfect with the non-experiential existential, but when observing the resulting state together with the addressee, he would use the perfect with the GEM. In that case, the GEM might go along with an emphatic connotation, such as pride about one’s own strength, etc., or as an exhortation for the addressee to do as much as the speaker or even more, while the copula may be used for a neutral information, (161), alternative a. In other contexts, the GEM also indicates that the speaker is already informed, so that there is an asymmetry of knowledge between speaker and addressee, (161), alternative b. By contrast, when the speaker finds out a new fact together with the addressee, the visual marker can be used, although there is no speaker-hearer asymmetry, (162), first part. In these contexts, the GEM, as used by the Faɖumpa speaker, seems to be mainly motivated by the explanatory mood, to be described in the next section (3.4.3), and/ or by an emotionally coloured emphasis, cf. section (3.3.9) above.

(161) a. Faɖumpa (Kenhat, Central Zanskarpa, field data 2019)

ŋe nan ji ŋe-tshar-ɖe-noʔ, / *ŋe-tshar-ɖe-in,* /
 I+ERG row 2 harvest-complete-LB+GEM=PERF harvest-complete-LB-CP=ASS.PERF
ŋe-tshar-ɖe-met. *ta lyi-hen-bo kherã-e ŋe!*
 harvest-complete-LB-NG.EX=ASS.PERF.NRS⁸⁷ now be.left-NLS-DF fam.you-ERG harvest=IMP

⁸⁷ For the perfect of negative result, cf. also n. 60, p. 40 above. The construction emphasises the disappearance or complete destruction of the item transformed, here that the grain on the particular part of the field is completely harvested. The literal translation would be ‘I have harvested two rows [of the field], and nothing is there.’ The perfect of negative result is formed with all three negated existential auxiliaries: *yod*, *ɥdug*, *rag*, but cannot be formed with the negated copula and thus also not with the negated GEM.

'I (have) harvested two rows [of the field] completely (**as you can see!**; **I tell you** / for your information / out there), now, you do the rest!' (The GEM is used when standing with the brother in front of the field. It may go along with a connotation of exhortation or also of pride. / The copula can be used neutrally in front of the field, when simply informing the brother about who had done the work. / The non-experiential marker is used when coming home and telling the brother to do the rest.)

b. Faḍumpa (Kenhat, Central Zaskarpa, field data 2019)

izam-zɪʔ khow+e ŋɛ-ðe-noʔ. ta lyi-hen-bo kherã-e ŋɛ!
 that.much-LQ they+ERG harvest-LB+GEM=PERF now be.left-NLS-DF fam.you-ERG harvest=IMP
 'They have harvested that much (**as you can see; I tell you**). Now, you do the rest!'

(162) Faḍumpa (Kenhat, Central Zaskarpa, field data 2019)

wa, am+e mobail khjõ-ðe-duʔ! / am+e mobail khjõ-ðe-inoʔ.
 intj mother+ERG mobile bring-LB-VIS=PERF mother+ERG mobile bring-LB-GEM=PERF
 'Hey, [our] mother has brought a mobile phone (what a surprise)! / [Your] mother has brought a mobile phone (**as you can see; I tell you**).' (In the first case, speaker and addressee become aware of the unexpected fact together. / In the second case, the speaker, e.g., the father, has already the relevant information and tells the children as soon as they come in and can see the mobile phone.)

The perfect construction can be used for an ongoing situation, cf. also section 3.4.4.:

(163) a. Rumbakpa (Kenhat, Central Ladakhi, field data 2017)

ŋ-e ige qi-ste-in.

I+ERG letter write-LB-CP=ASS.PERF

'I am writing a letter. / I have written a letter.' (The addressee has just come in. The perfect reading is enhanced when the word order is inverted. – In the eastern Kenhat dialects, the perfect reading may depend on the presence of the ergative marker.)

b. Rumbakpa (Kenhat, Central Ladakhi, field data 2017)

kho-a snat ma-ɖu he! kho-e qi-ruk. /

s/he-ALL provocation NG-dig=PRHB intj s/he-ERG write-VIS=PRS

qi-ste-nok, thoŋ-a-mi-rug-aʔ

write-LB-GEM=PERF see-NLS-NG-VIS=PRS-QM

'Don't provoke/ irritate him/her. S/he is writing (you might not see it). / S/he **is writing**, don't you see?' (The visual marker can be used when the addressee does not see the person or to draw the attention of the addressee to a particular situation. / The generalised perfect is used when the addressee **could observe the situation**, the addressee may have been asking about the situation, and the speaker **explains**.)

3.4.2 *Shared activities*

While the speaker from Gya-Miru does not use the GEM for shared observations, she may use it when talking about results from activities performed together by speaker and addressee, example (164). The GEM may also be used when talking about ongoing shared activities. However, talking about activities both speaker and addressee are involved in is not very common, and one needs some special context to do so. Asking for silence may be one of the few contexts that make such statements natural, example (165).

In a similar context, the Faḍumpa speaker uses a complex combination with the existential perfect and the GEM. This is necessary, as the combination of the continuous form with the copula is not available in this dialect. His example (166) also shows that the construction depends on the use of the inclusive plural pronoun. In these cases, speaker and addressee both share the access to the knowledge at hand. The speaker thus cannot claim it as his/her (exclusively) personal knowledge, to have privileged access, or to know it better than the addressee does.

- (164) Gya-Mirupa (Kenhat, Upper Indus dialects, field data 2022)
daŋ oyo-hun-e ŋē-re-inak. tɕfia deriŋ tɕk-te kjē-en.
 yesterday we.incl-PL-ERG harvest-LB-GEM=PERF therefore today bind-LB carry-CP=ASS.FUT
 ‘Yesterday, we (including you) **have harvested** [the field completely] (speaker-hearer **symmetry**). Therefore, today [we] shall bind up [the sheaves] and transport [them] [to the threshing ground].’
- (165) Gya-Mirupa (Kenhat, Upper Indus dialects, field data 2022)
oyo tshaŋma iru sil-en-inak, sil-en tɕi-en-inak;
 we.incl all here study-CNT-GEM=PRS study-CNT write-CNT-GEM=PRS
dʒudʒu kūfo mā-taŋ!
 please noise NG-give=PRHB
 ‘We (including you) **are** all **studying** here, studying and **writing**; [so] please be silent!/ don’t make [that much] noise!’ (Speaker-hearer **symmetry**: the speaker has no privileged knowledge and does not know it better than the addressee does.)
- (166) a. Faḍumpa (Kenhat, Central Zanskarpa, field data 2019)
taʔsa haɣo leha fθ-in-jot-e-noʔ; habɣot ma-taŋ!
 now we.incl work do-CNT-EX-LB-GEM=PERF laughter NG-give=PRHB
 ‘We (including you) **are working** now; stop laughing!’ (Speaker-hearer **symmetry**: the speaker has no privileged knowledge and does not know it better than the addressee does.)
- b. Faḍumpa (Kenhat, Central Zanskarpa, field data 2019)
taʔsa ŋaɣa leha fθ-in-jot; θiŋna foʔ!
 now we.excl work do-CNT-EX=ASS.CNT.PRS afterwards come.IMP
 ‘We (other than you) are working (right now); [please] come later!’ (Speaker-hearer asymmetry: The speaker has privileged access through his/her involvement, while the addressee has not.)

3.4.3 The explanatory mood: shared and shareable knowledge (profiling the addressee’s interests and knowledge)

In most dialects, the GEM is used in explanations, concerning both situations from one’s personal sphere, cf. (173), and situations more generally accessible to others. In statements, the speaker assumes that the addressee either already knows the fact or does not know it yet. This will probably be seen as a paradox. However, in the first case, the GEM indicates that the speaker does not claim exclusive personal knowledge, while in the latter case, the GEM additionally functions as a friendly invitation to share this knowledge,⁸⁸ similarly indicating that the speaker will not claim exclusive personal knowledge.

⁸⁸ As mentioned above, p. 13, I owe this idea to Diane M. (or Daniel J.) Hintz.

When the GEM is used, the facts are presented as generally knowable, and, as the Sumurpa informant stated, it does not matter how the speaker came to know the facts. This would perfectly correspond to descriptions of the assumed ‘non-evidential’ character of the ‘factual’ markers in Standard Spoken Tibetan, such as the following one by DeLancey (2018: 583, 588):

The speaker feels no need to justify the claim, and asks the addressee to simply take it as given. [...] But this establishes the true function of the Factual category: it simply disregards the question of evidence.

Far from being neutral, however, *inok* & siblings (that is, in the case of the Sumurpa informant: the GEM *intsuk*) signal that the speaker is open for further discussion or ready to give more details, that is, the content of the statement is *at issue* (or debatable). As the same Sumurpa informant further stated, as a listener, she would be more likely to ask back, when the facts are presented with the GEM than when they are presented as personal knowledge or even authoritative personal knowledge. In a similar vein, the Rumbakpa informant stated that she would use the assertive markers to avoid further discussion, indicating thus that the content of such statements is *not at issue* (or not debatable). Accordingly, questions with the GEM indicate one’s friendly or also casual curiosity, in contrast to authoritative inquiries with the assertive markers (see also section 3.4.5, for an even more discussion-friendly construction).

A second motivation for the use of the GEM in generic contexts is that the speaker cannot, or does not want to, claim responsibility for, or even creatorship of, the situation, cf. example (179).

While most speakers would automatically switch to the respective GEM, when explaining things, speakers from Purik and from the Turtuk area would prefer the plain copula for a neutral explanation. Nevertheless, in the dialects of the Turtuk area, both *inmaj* and *intsuk*, in their generalised function, appear in explanations, if only sporadically. Unlike the inferential or hearsay usage, this generalised usage appears to be restricted to present (or near past) time references. My first impression was that *intsuk* may indicate that the content is not very important or serious, see examples (167) and (169), but there are also other cases, where this interpretation does not apply, at all. With respect to example (167), I was able to collect a parallel example, (168), from the Faḍumpa speaker. He stated that the GEM does *not* signal that one is not fully convinced or not fully serious. However, the plain copula could not be used, because the truth talked about is not something one has just created oneself and proved; it is a truth or belief that has come down from the elders.

- (167) Thangpa (Eastern Baltipa, 2022), *Animals in our village*
bifu.mar ḍ-m+at. bifu.mar-la rdoa tã-ma-na,
 weasel come-NLS+EX=ASS.HAB weasel-ALL stone give-NLS-CD
ba:ŋ nor-la noksan taŋ-ŋa. sahi in-tsuk!
 cow goat/sheep-ALL damage give-GRD true be-INF/DST(=GEM)
 ‘[In our village] there is [also] the weasel (lit. red cat). If one throws a stone at the weasel, it will bring harm to the cattle and the goats and sheep. This **is (really) true!**’⁸⁹

The last sentence is an assertion in the context of an explanation or factual information. It constitutes neither an inference, nor hearsay knowledge, but knowledge shared in the village community. It also indicates the strong conviction of the speaker.⁹⁰

⁸⁹ In Ladakh, the weasel is said to bring riches. Accordingly, if one harms it, it would take revenge. Apparently, the weasel has the same auspicious symbolic value as the mongoose or ichneumon in the Indian tradition.

- (168) Faḍumpa (Kenhat, Central Zanskarpa, field data 2023)

kalte lakimo-a ḍoa jap-ne,
if weasel-ALL stone throw-CD

lakim·e kherā-la notpa tã-a·no? ḍenba _ no?.
weasel-ERG fam.you-ALL damage give-NLS·GEM=DPG true be=GEM

‘If [you] throw a stone at a weasel, it will send you harm. [This] **is (really)** true. (I have not made this up; this is a common belief.)’

Example (169) was a spontaneous comment on the use of a lock. While a lock would not prevent a thief from burglary, it helps preventing an honest person from temptation. In this context, the speaker expounded how he might be tempted by seeing something precious. He further demonstrated how in his village, people might tie the lock to a door or gate simply with a piece of cloth. This device would be enough to signal to an ordinary person that ‘you are not expected to enter’.

- (169) Tyaksipa (Eastern Baltipa, 2022), *The lock*

rdos-po mi ljaχ-la doafari in-tsuk :

lock-DF person good-ALL therefore be-INF/DST(=GEM)

rdos taη-se-met-na, de naη-p·eanu ljaχmo laxf·e thoη-na

lock apply-LB-NG.EX=PERF-CD that room-DF·PPOS good thing+GEN=LQ see-CD

kho-e-saη sniη khjor-et.

he-GEN-FM heart go.astray-EX=ASS.PRS

gi spera gaηm·e khutpo d·o in :

this talk all·GEN essence that·DF be.ASS

rkunma-la rdos-i f·aη rtsiruk-fī met.

thief-AES lock-GEN what·FM esteem-LQ NG.have.ASS

amma mi ljaχ-la sniη khjor-et zer-e,

but person good-AES heart go.astray-EX=ASS.FUT/HAB say-LB=CNJ

rdos taη-ma-in-tsuk.

lock apply-NLS-CP-INF/DST(=GEM)

‘The lock **is** [only] for the reputable (lit. good) persons because of that: if a lock is not applied, [and] if [a reputable person] sees a precious (lit. good) thing in that room, he, too, will yield to temptation (lit. his heart will go astray). In short, the thief has no respect at all for a lock [he will simply break it], but lest a reputable person’s heart may go astray, [one] **applies** a lock.’ (Spontaneous **explanation**, after discussing the need to prepare in time for a journey and not to search for a lock in the last minute.)

- (170) Tyaksipa (Eastern Baltipa, 2022), *Birds*

biu baktfi+(·) zost·o d·o in-tsuk :

small.bird some·GEN manner·DF that·DF be-INF/DST(=GEM)

ki rgun-la tshatjul-a go-a-in-tsuk,

CNJ winter-ALL heat.country-ALL go-NLS-CP-INF/DST(=GEM)

zajar-la graχm·e maltsa+(·) duk-pa-in-tsuk.

summer-ALL cold·GEN place·ALL stay-NLS-CP-INF/DST(=GEM)

⁹⁰ In 2023, I had a discussion with some Baltipa speakers about whether the past was better than the present. One of them stated that in the past, 90% of the people were good, now, 90% were bad. When I signalled my doubts, he confirmed his point of view with a boldly uttered *intsuk!* ‘Yes it is so!’, indicating that I should definitely believe him.

‘The manner of some birds **is** that: that in winter they **go** to a hot/ warm country [and] in summer they **stay** in cold/ cooler places.’ (**General knowledge.**)

Example (170) might still be seen as a case of mere hearsay knowledge. However, in (171), this is no longer possible. The speaker answers a question about a custom within his community, in which he is actively involved. He would not prepare the ‘street soup’,⁹¹ but he would preside the prayers and offer some preaching.

(171) Tyaksipa (Eastern Baltipa, 2022), *Food donation*

safar-i stranj-b-i bale
safar-GEN street-GEN soup
ataapo+n-ena drul-en-jot-p-i las 'tsir-fik in-tsuk.
 father.grandfather+PL-PPOS:ABL go-CNT-EX-DF+GEN work.row-LQ be-INF/DST(=GEM)
d+o defila in-tsuk :
 that+DF that.for be-INF/DST(=GEM)
bala-banf-fat-na stranj-se-duk-fik! zer-e.
 accident-calamity-ABL protect-LB-stay-DM say-LB

‘The ‘street soup’ of the second Islamic month (*safar*) **is** a tradition that comes from our forefathers. That one **is** for that [reason]: that it may protect continuously against all calamities [associated with this month].’ (**Explanation** for BZ, who had witnessed some preparations and was curious enough to ask what this soup is for.)

It also appears that in the Baltipa dialects of the Turtuk area, *intsuk* is used for abstract and generic situations, while *inmanj* may be preferred for concrete, individual situations and when trying to talk nicely or politely, (172).

(172) Turtukpa (Eastern Baltipa, field data 2017)

gi-u mobail in. / apo, gi-u mobail in-manj.
 this+DF mobile.phone be.ASS grandfather this+DF mobile.phone be-EXP(=GEM)
gi-u fo:n tanj-m+ephia in. / in-manj.
 this+DF phone give-NLS+PPOS be.ASS be-EXP(=GEM)

‘This is a mobile phone. / Grandpa, this **will be** a mobile phone. This is / **will be** for making phone calls.’ (The plain copula is used for a neutral statement or explanation. / The GEM may be used when talking nicely [e.g., to show one’s attachment] or when being more polite. The English translation cannot capture this notion.)

In all other dialects of the core area, the GEM, rather than being marginal, is the expected copula or auxiliary in explanations.

(173) Hundarpa-Sumurpa (Shamskat, Ldumrapa, field data 2016)

njai rgompa fhenmo jot. ... gniypa intsuk.
 we.excl.GEN monastery big be(X).ASS old be=GEM

‘Our monastery is big. ... [Yes,] [it] **is (really)** old (**as you might want to know/ as you expect/ as all of us know**).’ (From a conversation with the mother of the Sumurpa infor-

⁹¹ The ‘street soup’ is not necessarily a soup. A free midday meal is prepared in the masjid as a donation every Wednesday during the month of *safar*. In the Shia tradition, the second month is associated with quite a few cases of martyrdom, death, and murder of religious figures.

mant, who grew up in Hundar. The first sentence was uttered spontaneously, the second one after I asked back – most likely not with the most suitable form.)⁹²

- (174) a. Tagmacikpa (Shamskat, Western Shamma, field data 2019)
d·u mobail intsok. di-an ηataŋ-as spera taŋ-ba-nen-e-intsok. /
 this+DF mobile be=GEM this-PPOS we.incl-ERG speech give-NLS-be.able-LB-GEM=PERF
taŋ-ba-nen-ŋas-intsok. (~taŋ-ba-nen-ŋ·entsok.)
 give-NLS-be.able-GRD-GEM (~give-NLS-be.able-GRD+GEM)
 ‘This **is** a mobile phone. We **can** speak / **will be able** to speak through (lit. in) this.’ (The speaker **introduces** and **explains** the functions of the item.)
- b. Tagmacikpa (Shamskat, Western Shamma, field data 2019)
d·u η·i phoun soma in. d·u-a ston ʃoŋa khe:s.
 this+DF I+GEN phone new be.ASS this+DF-ALL 1000 15 take.PA
jaŋ di-an nakʃa gjap-pa-nen-en-(d)uk. /
 again this-PPOS picture take-NLS-be.able-CNT-VIS=PRS
gjap-pa-nen-ŋ·en. / *gjap-pa-nen-ŋ·entsok.*
 take-NLS-be.able-GRD+CP=FUT take-NLS-be.able-GRD+GEM
 ‘This is my new phone (personal mode). It cost me 15,000 [rupees] (lit. [They] took 15,000 for this). And with (lit. in) this [I/ one] can take pictures (as I just found out / as is generally known and I have experienced / as it **is certain [and you/ others may know]**).’

Here, the neutral future construction (GRD+*yin*) is used for a more general statement. According to the informant, the gerundive construction with the GEM makes the information more certain. But the GEM could possibly also indicate that the addressee is expected to know or that the speaker thinks that most people would know. The gerundive construction with the GEM may also function as a suggestion or invitation to act, see section 3.2.4 above.

- (175) Domkharpa (Shamskat, Western Shamma, field data 2011)
wase khitsoks-i semfen-i riks intsok.
 fox dog.like-GEN animal-GEN class be=GEM
 ‘The fox **is** [of] the class of dog-like animals [i.e., the fox **is** a dog-like animal.]’ (Fact expected to be, or presented as, **generally known** or presented in an **explanatory mood** to somebody who does or might not know, e.g., in school.)
- (176) a. Domkharpa (Shamskat, Western Shamma, field data 2012)
gjawa izin nurbu-s «mi tshayma tsoks intsok» mol-khan-bo
 Gyawa Ižin Nurbu-ERG person all equal be=GEM hon.say-NLS-DF
η·i spin-a zen.
 I+GEN heart-ALL affect=PA
ʃiba zer-na, di spera ʃhozluks-i spera mentsok.
 why say-CD this speech religion.manner-GEN speech NG.be=GEM

⁹² The daughter of this speaker, the Sumurpa informant, thought that the existential linking verb should have also been used when telling somebody who does not know. However, she would also not use the copula and hence also not the GEM for attributes, except in constructions of contrasting or comparing. In most dialects, however, age-related attributes trigger the copula and hence, where feasible, also the GEM for the MSAP and items in his/her personal and cultural sphere.

‘Gyawa Izin Nurbu’s [i.e., H.H. the Dalai Lama’s] statement that «all men **are** equal», is completely in accordance with my own thoughts. Because this **is not** [solely] a religious truth.’ (The cited statement concerns a fact that is accepted by the cited speaker and *presented* as generally known and acceptable – even if it were not generally accepted, cf. also the following alternative b. The comment by the reporting speaker points to the generic value of the cited statement. The comment itself is *presented* as a generally acceptable truism, not something the reporting speaker just found out.)

b. Lehpa (Kenhat, Central Ladakhi, Koshal 1979: 92, ex. I, my translation)

rgjalpo-dan lama koj-a phut! tene tshanma tsoks inok.

king-COM lama above-ALL let.go=IMP then all equal be=GEM

‘Apart from kings and lamas at the top, all **are** equal. (Lit. Leave aside the kings and lamas at the top, then all [others] **are** equal.)’

(177) Khalatsepa (Shamskat, Western Shamma), *Village history* (recorded 2006)

Brokpa-s «Brokrgjut intok» zer-e-intsok. o le.

Brokpa-ERG Brok.lineage be=GEM say-LB-GEM=PERF that HON

‘[Let me explain:] the Brokpa (‘Dards’) have (always) been saying that [they] **are (as everybody in Khalatse knows)** of the Brok [that is, Gilgit] lineage. That [is how it is].’ (The first GEM inside the reported speech represents **common knowledge, shared by the people of Khalatse**.⁹³ The second GEM in the perfect construction concerning the utterances of the Brokpa is used, as the speaker explains a fact to BZ, who, as an outsider, cannot know it, but seems to be interested.)

In the following example from the Kesar epic, the king asks an old lady about something only she can know and for which she is presumably responsible. Her assertive answer shows exactly this. However, with the use of the GEM, the king asks for an explanation and indicates his friendly curiosity – in contrast to an authoritative inquisition. The old lady, however, is not in the mood to give an explanation and tries to cut short any further discussion. The question does not aim at the knowledge state of the addressee, but is motivated by the speaker’s own attitude towards the content of that knowledge. This attitude may be compared to that of a speaker who asks about the identity of a person who is not or no longer present, as described in section 3.3.4.

(178) Stokpa (Kenhat, Central Ladakhi), *Kesar* (recorded 1996)

«abi fi inok, phats+enaja gul-kan-zik duk-pa?»

grandmother what be=GEM sack+PPOS move-NLS-LQ exist.VIS-emp

zers-pa, «ta gjapo khen, fhak-tfe-zik jot.

say.PA-NLS now king please break-GRD-LQ exist.ASS

gul-tfe-zik fi-an med-le.» zers-pa,

move-GRD-LQ what-FM NG.exist.ASS-hon say.PA-NLS

‘«Grandmother, what **could this be**, (I see that) in the sack, there is something that moves?» [he] said. «Oh my king, please, (I can assure you), there is [only] something breakable [inside], there is not anything moving (I can assure you/ that’s all I have to say),» [she] said.’

Apart from the fact that one does not have exclusive knowledge, the GEM may additionally signal that one is not in any way involved in, or responsible for, the reported situation.

⁹³ The village is said to have been founded by Brokpa settlers, see also Zeisler (2022b: 734–737).

- (179) Kārgyampa (Kenhat, Lalokpa, field data 2016)

*ɖɪkten rilril ɦɪndak. / *ɦin.*

earth round be=GEM *be

‘The earth **is** round (and this **is a given fact**).’ (For the informant, the unmodified copula would sound as if the speaker made the world him/herself. A person who went or sailed etc. around the earth could possibly use the copula, indicating with it that s/he measured it and thus knows it well; nevertheless, it would be more polite to use the GEM.)

- (180) Pangipa (mixed variety, Himachal enclave, field data 2017)

ɲɛ jɪl ɡonʃ, ɦɛnem kɛmer ɡon-ʃ-en.

we.excl.GEN village dress salwar kameez dress-GRD+CP=FUT

pent ɡon-ʃ-men. ʃia zer-nɛ, pɦejat ɦinnɛ.

pant dress-GRD-NG.CP=FUT why say-CD shameful be=GEM

‘In our village, [we women] wear salwar and kameez [as] dresses. [We] don’t wear pants, because this **is** [considered to be] shameful.’ (The possible implied readings of the GEM are: 1. **as everybody of our village knows**; 2. I explain, **as you might not know**; 3. **this is a given fact beyond my control**.)

One of the speakers who do not use the GEM for themselves in order to indicate their shyness or even shame (see section 3.3.7) explained that he could use the GEM for himself, as soon as he gives more information.⁹⁴ This is especially the case when contradicting incorrect assumptions about himself. In such cases, he might use first the plain copula for the contradiction and subsequently the GEM for the explanation (181), alternatives a. and b. But he may also directly contradict the assumption with the GEM, alternative c. This usage differs from the above-described expression of shyness or shame, including the sarcastic usages discussed in sections 3.3.7 and 3.3.8. First of all, the GEM is in these cases not restricted to negatively connoted professions or low status. Secondly, it is always tied to a contextually given wrong assumption by the addressee. Furthermore, the GEM could not be used independently, e.g., when introducing, or simply informing about, oneself.

- (181) a. Kharnakpa (Kenhat, Himachal border dialect, field data 2018)

khjɔʔ ɡergen ɦin-aʔ – ɲa ɡergen maɳ. ɲa ʈuris ɡaiʃ ɦinɖaʔ.

fam.you teacher be.ASS-QM I teacher NG.be.ASS I tourist guide be=GEM

‘Are you a teacher (expecting assertion)? – No, I’m not a teacher (assertive), I’m a tourist guide (**as you might want to know; and I am ready to give more details**).’

- b. Kharnakpa (Kenhat, Himachal border dialect, field data 2018)

khjɔʔ ɦaɡzi ɦin-aʔ – ɲa ɦaɡzi maɳ. ɲa ɡergen ɦinɖaʔ.

fam.you yak.herder be.ASS-QM I yak.herder NG.be.ASS I teacher be=GEM

‘Are you a yak herder (expecting assertion)? – No, I’m not a yak herder (assertive), I’m a teacher (**as you might want to know; and I am ready to give more details**).’

- c. Kharnakpa (Kenhat, Himachal border dialect, field data 2018)

khjɔʔ ɡergen ɦin-aʔ – ɲa ɡergen maɳɖaʔ.

fam.you teacher be.ASS-QM I teacher NG.be=GEM

‘Are you a teacher (expecting assertion)? – No, I’m **not** a teacher (**you might want to correct your error; and I am ready to give more details**).’

⁹⁴ See Yliniemi (2019: 272f. with exx. 7.43b, 7.45, 7.46b, 7.48) for a related usage of the ‘neutral’ copula in Denjongke.

In the Eastern Purikpa dialects, the attitude expressed in explanations differs. According to the Ciktanpa informant, the GEM is used only when the speaker expects the addressee to already know, whereas the assertive markers are used when the speaker expects the addressee not to know. Note that for corresponding existential usages, the GEM may combine with the existential linking verb into a perfect construction (compare also examples (7) to (9) on p. 29 and the second alternative of example (213) on p. 119). Here, as in most dialects, the existential perfect with the GEM does not have exactly the same value as the GEM itself. It seems to be more emphatic.

- (182) Ciktanpa (Shamskat, Eastern Purikpa, field data 2016)
ʃiktan-la zi(k)-khan-i khar-po jot-e-intsuk. / jot.
 Ciktan-ALL ruin-NLS-GEN castle-DF exist-LB-GEM=PERF exist.ASS
 ‘In Ciktan, there is a ruined castle (**as you know** / as you might not know).’

- (183) Ciktanpa (Shamskat, Eastern Purikpa, field data 2016)
ʃiktanpa-tsag-a rta met-pa-intsuk.
 Ciktan.people-PL-AES horse NG.have-NLS-GEM=PERF
 ‘The people of Ciktan **do not have** horses (**as you know**).’

According to the Mulbekpa informant, the GEM would only be used when telling children facts that they do not know yet, but not when talking to adults who might not know. However, this latter restriction might be more typically linked to the replacement of the existential linking verb with GEM as copula.

- (184) a. Mulbekpa (Shamskat, Eastern Purikpa, field data 2018)
kheraŋ mulbeg-na thur-la ʃha-na kargilo jot.
 fam.you Mulbekh-ABL down-ALL go-CD Kargilo exist.ASS
 ‘If you go down from Mulbekh, there is/ will be Kargilo.’ (Talking to an adult.)
- b. Mulbekpa (Shamskat, Eastern Purikpa, field data 2018)
Mulbeg-na thur-la ʃha-na, kargilo intsuk.
 Mulbekh-ABL down-ALL go-CD Kargilo be=GEM
 ‘If [one] goes down from Mulbekh, there **is/ will be** Kargilo.’ (**Explaining to a child.**)

Both the Ciktanpa and the Mulbekpa description may possibly need some qualification. That is, the choice of the GEM may depend somewhat less predictably on the particular communicative situation. Example (185) from the Kargilopa dialect shows the use of the GEM in an information-seeking question and the corresponding answer, which concern a generic fact, namely a specific day. Nothing in the question or in the answer indicates that the second speaker has to look up the day in a calendar or the like. Unfortunately, no particular context is given. Zemp (2018: 274), who is at this point only concerned with the nature of the question word *ʃi*, simply states that the answer is of a general nature. The translation further indicates that the first speaker may have known the fact, but forgot it. The GEM may additionally be motivated by an attitude of distance or unrelatedness: as Muslims or, if Zemp was involved in this conversation, as Non-Hindus, both speakers might not have been very interested in, or affected by, the fact.

(185) Kargilopa (Western Purikpa, Zemp 2018: 275, ex. 625, slightly adapted)

[A:] *dirij fi zaq in-suk?* –
 today what day be-INF/DST (=GEM)

[B:] *mahatma gandhi-i skjezaq in-suk.*
 Mahatma Gandhi-GEN birthday be-INF (=GEM)

[A:] ‘What [kind of] day **is it (again)** today?’ – [B:] ‘**It’s** Mahatma Gandhi’s birthday.’

With respect to items in one’s personal sphere or territory of information, the Faḍumpa dialect shows a particular distribution: the GEM can be used neutrally to simply convey the information, while the plain copula should be used when answering a question.

(186) Faḍumpa (Kenhat, Central Zanskarpa, field data 2022)

ŋ-e aba kounsalar hin. / %hinba. / hinok.
 I+GEN father councillor be.ASS %be.ASS-emp be=GEM

‘My father is councillor.’ (The plain copula is used for the answer when asked about the father’s job. / The emphatic marker would indicate that the speaker is very proud about the fact. / The GEM has the function of – in the words of the informant – “**just giving the information, that’s all.**”)

The GEM may further be used when pointing out photographs. In that case, one factor in the choice of markers is whether one has taken the picture oneself, which facilitates the use of *yin* or *yod*, or whether somebody else has taken it, in which case other forms are preferred. An important second factor, however, is the assumed knowledge asymmetry between speaker and hearer. That is, when pointing out something from the photograph that is unknown to the addressee, the GEM may be used, even if the item should belong to one’s personal sphere.

As the Tagmacikpa speaker explained, this may depend, as a third factor, on whether one emphasises more one’s own personal knowledge or authorship, in which case the plain copula is used, or whether one focuses on the knowledge gaps of the addressee, in which case the GEM is used. Version a. of example (187) focusses mainly on the addressee’s knowledge gaps, but it also shows the multifunctional character of the GEM, which in the last sentence indicates that the speaker just realised a fact. In version b., the GEM might be additionally motivated by the speaker’s respect towards the monastic institution, to which she might feel less closely associated than to the rest of the village. The last sentence reflects the speaker’s choice to ease the knowledge gap. Version c. contrasts the speaker’s authorship of the photograph with the speaker’s empathy for the addressee.

(187) a. Tagmacikpa (Shamskat, Western Shamma, field data 2019)

d·u ŋaf·i jul in. di karmo tshayma khampa intsok.
 this+DF we.excl+GEN village be.ASS this white all house be=GEM

di+(:)joga zij tshayma intsok. di marpo tshayma ffuli intsok.
 this+PPOS field all be=GEM this red all apricot be=GEM

di karmo rijbo-tsak zbjarpa intsok.
 this white long-PL poplar be=GEM

jan d·u rtsanspo rgjuk-se-intsok.
 again this+DF river flow-LB-GEM=PERF

jul-irgiappona ri (thoj-se-) intsok.
 village-PPOS:ABL/LOC mountain (see-LB-) be=GEM (=PERF)

rijo tshayma+(:) kha intsok.
 mountaintop all·ALL snow be=GEM

‘This is our village [one can clearly see the village]. Those white [spots] **are** houses (I know, **but you only see white things there**). Below them **are** the fields. These red [spots] **are** apricots [spread for drying]. These long whitish [things] **are** poplars. And here (lit. this), **flows** the river [Indus]. Behind the village **are** the mountains. / the mountains **are visible**. Apparently, there is snow on the mountaintops (**as I just realise**).’ (The speaker describes a picture of her village on her smart phone and **explains** what is to be seen.)

b. Tagmacikpa (Shamskat, Western Shamma, field data 2019)

d·u ɲaf·i gompa intsok.
 this+DF we.excl+GEN monastery be=GEM
d·u skora fhas+e lam intsok.
 this+DF circumambulation walk.place-GEN path be=GEM
di tshayma tʃafak intsok. ...
 this all monk.quarter be=GEM
di+(·)joga khanba tshayma jot. / jot-e-intsok.
 this+PPOS house all exist.ASS exist-LB-GEM=PERF

‘This **is** our monastery. This **is** the path for the circumambulation. These [here] **are** the monk quarters. ... Below this [here, in the foreground] **are** the houses (I know it, of course, even if we can’t see them / as **you might want to know**).’ (The informant points out a photograph of her village in her smart phone and **explains** what is to be seen. – When talking about the houses of her village, which are not visible on the photograph, the speaker may profile her own involvement or belonging with the plain existential or she may **profile the interest of the addressee** by using the perfect construction with the GEM.)

c. Tagmacikpa (Shamskat, Western Shamma, field data 2019), suggested translation

d·u fiktan-i jul in. / intsok.
 this+DF Ciktan-GEN village be.ASS be=GEM

‘This is the village of Ciktan.’ (The speaker, here BZ, has shot the photo. The plain copula emphasises her authorship. / The GEM, according to the informant, “**gives more importance to the audience**” and is thus more polite.)

One should add as a fourth factor the relationship between speaker and addressee in relation to each one’s relationship to the situation spoken about, as mentioned independently by the Faɽumpa speaker and the Lehpa speaker (for the latter, see example (112) and the introductory remarks to it on p. 74 above). In most scenarios with photographs of persons so far collected, the speaker points out family members to an outsider, and it seems natural that the relationship to one’s own family members counts more than the knowledge state or interest of the outsider, and that, therefore, the plain copula is used. When pointing to a person from the village, the speaker can choose between the plain copula, which then signals a friendly and close relationship, and the GEM, which signals personal distance. When pointing to an unrelated person, the plain copula may be no longer possible.

(188) a. Gyaikpa (Kenhat, Upper Indus dialects, field data 2017)

go-ekane hot-kan-de ɲaj·e azan hin. / hinak.
 door-PPOS:ABL/LOC exist-NLS-DF we.excl+GEN uncle(MB) be.ASS be=GEM

‘The one by the door is our uncle (mother’s brother).’ (Looking at a photograph; the plain copula indicates that the speaker is sure [and is acquainted with the photograph]. / The GEM indicates that **the speaker** [is not fully acquainted with it and] **suddenly realises who this is**.)

b. Gyaikpa (Kenhat, Upper Indus dialects, field data 2017)

goeka-ne hot-kan-de goba hinak. / hin.

door-ABL/LOC exist-NLS-DF village.head be=GEM be.ASS

‘The one by the door is [our] village head.’ (Looking at a photograph; in this case, as the village head objectively belongs to the speaker’s territory of information, the GEM indicates a **distanced attitude**. / The copula indicates that the speaker knows the person well [and sympathises with him/her].)

c. Gyaikpa (Kenhat, Upper Indus dialects, field data 2017)

*goeka-ne hot-kan-de tiri+(:) goba hinak. / *hin.*

door-ABL/LOC exist-NLS-DF Tiri+GEN village.head be=GEM *be.ASS

The one by the door **is** the village head of Tiri.’ (Looking at a photograph; **the speaker does not know the village head of another village well enough**. Being from a different village, the person does not belong to the speaker’s territory of information.)

Imagine further the following context: the speaker visits his/her sibling who studies abroad and has been absent from the family for, say, five years. The sibling, therefore, is not aware of the developments in the family. The speaker has a few photographs with him/her and shows these to his/her sibling. When the speaker can expect that the persons in question will be recognised immediately, s/he will choose the plain copula while pointing out the persons. If the speaker assumes that the sibling may have difficulties to recognise any of the family members (e.g., parents or grandparents showing unexpected signs of age, younger siblings having grown up, or even the speaker wearing something very fashionable or a new hair style or new glasses, etc.), then the speaker may choose the GEM to ease the knowledge asymmetry. The speaker may also choose the plain copula when disregarding the knowledge gap, focusing only on his/her own knowledge or demonstrating his/her pride about the fashionable look. The choice of the plain copula or the GEM thus also depends on the speaker’s personal attitude towards the addressee. One may see this as a question of respect or a question of compassion, and in other situations, also as a question of politeness.

(189) a. Tagmacikpa (Shamskat, Western Shamma, field data 2019)

d+u ηati ama in. / intsok.

this+DF we.incl.GEN mother be.ASS be=GEM

‘This is our mother (as you surely recognise – or if not, I don’t care / **as you might not recognise at once**).’ (The plain copula signals that the sibling is expected to immediately recognise the represented person or that the speaker does not care about it. / The GEM would be used when it is a new photo and **the sibling might have difficulties to recognise the mother** [and the speaker cares about filling the knowledge gap].)

b. Tagmacikpa (Shamskat, Western Shamma, field data 2019)

ltos-aη! d+u ηa in. / intsok, ηa stapfan mi-ndug-a?!

look.IMP-DM this+DF I be.ASS be=GEM I fashionable NG-be.VIS-QM

‘Look! This is me, am I not fashionable?!’ (The plain copula indicates that the speaker feels very proud and expects the addressee to recognise him/her easily. / The GEM indicates that **the speaker thinks s/he is difficult to recognise**.)

3.4.4 ‘Perfect’ facts: a developing generalised perfect construction (profiling the addressee’s interests and knowledge)

The present perfect construction (V-LB-Aux)⁹⁵ is often used with atelic verbs for ongoing situations, mainly with the auxiliary *yin* and mainly for the MSAP. Theoretically, it refers to ongoing resultative states after an initial act of beginning, but in actual usage, there is not much difference to present tense continuative constructions (Zeisler 2004: 783–786). The main effect is that beginning and end are conceived as being further away, and the situation is thus perceived as enduring even longer than when presented with a continuative present tense construction. The continuative present tense construction with the existential auxiliary *yod* may by contrast also indicate a more general situation with activities that have to be performed on and off over a longer period, such as writing a book, whereas the continuative present tense construction with the auxiliary *yin*, which is not available in all dialects, may focus on the ongoing situation right now. For both the continuative present tense construction with the auxiliary *yin* and for the continuative perfect with the auxiliary *yin* there is a certain tendency (depending on the dialect and/ or speaker) that the addressee must be present and observe what the speaker is doing.

In most dialects, the plain copula *yin* of the continuous perfect construction can be replaced by the GEM for various functions that are closely related to the functions of the GEM when used as copula. See also examples (158) to (163) in section 3.4.1 for results and ongoing situations observed by both the speaker and the addressee. The generalised perfect may be used even for facts from one’s personal sphere, when one talks in what I call the explanatory mood. In such cases, the GEM has completely lost any inferential value. This holds also for the Western Shamma form, (190)–(192).

(190) Tagmacikpa (Shamskat, Western Shamma, field data 2019)

angmo-s khiri gonlag-ŋun thu-se-intsok.
 Angmo-ERG fam.you.GEN dress-PL wash-LB-GEM=PERF

‘Angmo has apparently washed your clothes [they are here in front of us.] // **(Let me explain:/ Look,)** Angmo **has washed** your clothes [so you should change your attitude towards her].’ // ‘Angmo **washes** your clothes (**habitually**).’

Here, the combination of the perfect with the GEM may have various different functions:

1. The combination may be used here for an inference on the spot, e.g., first there were dirty clothes on the table, but when the speaker came back, there were again clothes on the table, which on closer inspection turn out to be clean.
2. The combination is also used in various dialects when speaker and addressee observe the situation together, because the use of the visual marker would indicate that only the speaker has made the observation (cf. section 3.4.1 above).
3. The combination may also be used for an explanation, e.g., the addressee does not like Angmo or has a grudge against her, so the speaker explains what Angmo has been doing for the addressee. In such case, it does not matter how one knows.
4. The combination may also be used for a habit or generic fact.

⁹⁵ Negation takes the form V-LB-NG.Aux or NG(*ma*)-V-NLS-Aux. The latter form differs from the negated present tense: V-NLS-NG-Aux and negated DPG-constructions V-NLS-NG.GEM and NG(*mi*)-V-NLS-GEM, cf. section 3.4.5.

Similarly, in the following example, the perfect construction may still express an inference with respect to an individually observed bound situation, version a., yet it may also refer to a generally known and unbound fact, version b.

- (191) a. Tagmacikpa (Shamskat, Western Shamma, field data 2019)
de phrugu-a thukpa zimpo tshor-e-intsok.
 that child-AES soup tasty perceive-LB-GEM=PERF
 ‘That child **must like** the soup.’ (The speaker **infers** this, observing the child while eating.)
- b. Tagmacikpa (Shamskat, Western Shamma, field data 2019)
phrugu-gun-la thukpa zimpo tshor-e-intsok.
 child-PL-AES soup tasty perceive-LB-GEM=PERF
 ‘Children (**generally**) **like** soup (**as everybody knows**).’

In example (192), on the other hand, it is clear from the context that the speaker does not make any inference, but knows the fact very well, being personally involved, and that s/he may feel responsible. In the explanatory mood, the GEM backgrounds one’s involvement and profiles the addressee’s (potential) interest to know. It may further signal that the speaker does not claim exclusive personal knowledge, since this knowledge is shared by all other villagers. One could possibly compare this usage with impersonal constructions, the use of German *man* or French *on*, roughly ‘one’, or the use of a passive. In 2022, the informant added that when talking to an outsider, the perfect with the GEM could also signal an exhortation to remember the fact.⁹⁶

- (192) Tagmacikpa (Shamskat, Western Shamma, field data 2019) – repeated from (110)
azay-le natf+i goba in. miy-a tsheriŋ aŋfuk intsok.
 uncle-hon we.excl+GEN village.head be.ASS name-ALL Tshering Angcuk be=GEM
khoy goba tfo-se lo rdun tsha-tf-en.
 hon.s/he village.head do-LB year 7 go-GRD+CP=FUT
azay-le jul-iphia datfan jot. dephia ma-spo-a-bor-e-intsok.
 uncle-hon village-PPOS devoted be.ASS therefore NG-exchange-NLS-keep-LB-GEM=PERF
 ‘That man (lit. uncle) is our village head. (Let me explain that) [his] name is Tshering Angcuk. It is going to be seven years, since he became (lit. did) the village head. He cares for (lit. is devoted to) the village. Therefore (**as I emphasise for you**), [we] **did not exchange** him.’

In example (193), an old lady from Leh remembers that she has seen five ‘kings’ in her live (three of them, in fact, as rulers, the fourth being the son of the last ruler, and the fifth being the latter’s child, still going to school). As the informant with whom I transcribed the recording stated, the speaker could well have used the assertive perfect *thoy-ste-in*. This form would be used to present new information as a matter-of-fact, not expecting (and not inviting) any discussion. It would sound a bit like *I tell you this happened, believe it or not*. The generalised perfect, on the other hand, would sound like *it happened, you know*. It could be used to counter the doubts of the addressee,

⁹⁶ In a further alteration of the context, the informant stated that when talking to a friend, she would use the plain copula both with the name: *miya tsheriŋ aŋfuk in*, and in the perfect construction: *maspoaborein*. This choice seems to have a more affirmative connotation. By contrast, in the same context of talking to a friend, the use of the perfect with the GEM would clearly indicate the speaker’s non-involvement with the situation.

and it would also indicate that there is a proof for the statement. In the case of the old lady, this would be the enumeration of the generations.

- (193) Lehpa (Kenhat, Central Ladakhi), *Five kings* (recorded 2015)
gjapo miŋpo dʒet-son-te-mi-rak, *ŋa+(:) teriŋ [...]*
king name forget-happen.PA-LB-NG-NVIS=PERF.NRS I+AES today
i gjapo kunzaŋ namgjal zu-kan-e
this king Kunzang Namgyal hon.call-NLS-GEN
aba-le, meme-le, nis-po fes-in le, ŋa(:),
father-hon grandfather-hon 2-DF know-CP=ASS.FUT hon I+AES
tene kunzaŋ namgjal-naŋ sum le, [...]
then Kunzang Namgyal-COM 3 hon
tene taks+e gjalu-bo-naŋ zi,
then present+GEN prince-DF-COM 4
tene te-w+e thugu-zik jot-kjak, sukul-a fha-kan-dʒik son-te,
then that-DF+GEN child-LB exist-DST school-ALL go-NLS-LQ happen.PA-LB
gjapo ta tene izugi ŋa-zig-i izugi thoŋ-ste-inok le.
king now then this.way 5-LQ-GEN this.way see-LB-GEM=PERF hon
‘The name of the king, I completely forgot, today [...] The father and grandfather of this [i.e., the last] king called Kunzang Namgyal, these two, I’ll know [in a second], then with Kunzang Namgyal three, [...] then with the present prince four, then there is a child of that one, who just became a schoolchild; kings, then, in this way, [in my life,] I **have seen** about five of them, **you know**.’

It may be noted that the recording was made after the lady had already told me that she had seen five kings in her live. The first time unfortunately went unrecorded. The lady was explicitly asked to repeat her story. This may or may not have affected her choice of the auxiliary.

Example (194) concerns a cultural fact of the speaker and his/her community, example (195) a fact generally known in the speaker’s community.

- (194) Tagmacikpa (Shamskat, Western Shamma, field data 2019)
ŋataŋ-is ldz+eaŋ zak sumfju jot-khan-bo thes-e-intsok.
we.incl-ERG month+PPOS day 30 exist-NLS-DF consider-LB-GEM=PERF
‘We (**generally**) **consider** a month as having 30 days [**as you might want to know**].’
- (195) Teyapa (Shamskat, Eastern Shamma, field data 2022)
rgun-la rfan jul-a bab-se-inok.
winter-ALL snow.leopard village-ALL come.down-LB-GEM=PERF
‘In winter, the snow leopard **comes down** to the village(s).’ (According to the informant, the generalised perfect indicates **a situation that is repeated and thus seen as continuing**.)

In order to emphasise the continuity of the situation, speakers may combine the explanatory perfect with the continuative construction:

- (196) Faðumpa (Kenhat, Central Zanskarpa, field data 2019) – repeated from (166) a.
ta?sa hayo leha fʃo-in-jot-e+no? habyot ma-taŋ!
now we.incl work do-CNT-EX-LB-GEM=PERF laughter NG-give=PRHB
‘We (including you) **are working** now [**as should be clear to everyone**]; stop laughing!’

As indicated in the context of examples (190) and (192), the combination of the perfect with the GEM may be used also to express generic or regularly occurring situations or states. For some speakers, the original inferential function may still dominate, and they may prefer another originally inferential construction, such as the future inferential, for presenting these situations as certain facts. The perfect construction, nevertheless, does refer to a generic situation, if only inferred on the spot:

- (197) a. Kārgyampa (Kenhat, Lalokpa, field data 2019)
māigrātori tēipa tshanma tōnka-la lōtēhog-la tēha-ak,
 migratory bird all autumn-ALL south.direction-ALL go-FUT.INF
jaŋ pīd-la lok-te-hoŋ-gak.
 again spring-ALL return-LB-come-FUT.INF
 ‘The migratory birds go to the south in autumn, and they come back in spring.’ (Speaking about a generally valid situation or natural law; preferred construction for an expert.)
- b. Kārgyampa (Kenhat, Lalokpa, field data 2019)
māigrātori tēipa tshanma tōnka-la lōtēhog-la soŋ-de-indak.
 migratory bird all autumn-ALL south.direction-ALL go.PA-LB-GEM=PERF
jaŋ pīd-la lok-te-hoŋ-de-indak.
 again spring-ALL return-LB-come-LB-GEM=PERF
 ‘The migratory birds (**apparently**) **go to** the south in autumn, and they (**apparently**) **come back** in spring.’ (The speaker and addressee are observing the birds flying, in reality or in a video. The speaker is not fully certain.)

For other speakers the inferential function may have bleached out (almost) completely in such contexts. I came across this usage only in 2019, when the Tagmacikpa speaker emulated a speech she had observed at the official World Migratory Bird Day. The original speaker most likely used the Lehpa forms *soŋ-ste-inok* and *joŋ-ste-inok* (or the DPG construction to be discussed in section 3.4.5), but the informant changed these to those of her own dialect.

- (198) Tagmacikpa (Shamskat, Western Shamma, 2019) *Migratory Bird Day*
jul spow+e ldapfaks zer-na,
 country exchanging+GEN winged.one say-CD
jul ffig-iaŋna jaŋ jul ffig-a fha-fas-po-a zer-et-sok.
 country 1-PPOS:ABL again country 1-ALL go.PRS-GRD-DF-ALL say-EX-INF/DST
fiba zer-na, rgun-la khardži rgjalba ma-thop-pa-na,
 why say-CD winter-ALL food good NG-get-NLS-ABL
ladaks-na jaŋ jul-gun-la soŋ-se-intsok.
 Ladakh-ABL again country-PL-ALL go.PA-LB-GEM=PERF
deana jaŋ zber-la ladagz-la khardži thop-pa-na,
 then again summer-ALL Ladakh-ALL food get-NLS-CD
ladagz-la joŋ-se-intsok.
 Ladakh-ALL come-LB-GEM=PERF
 ‘Talking about migratory birds, [one] says this for [their] going from one country to another. That is, because they do not find enough (lit. good) food in winter, they (**regularly**) **go** from Ladakh to other countries. Then in summer, when they can get food in Ladakh, they (**regularly**) **come** again to Ladakh.’ (The informant re-imagines a speech that she heard the other day, transforming it into her dialect. The original speaker would have used *inok*.)

The informant added that, by contrast, the form V-EX-INF/DST: *ʃh-et-sok, joŋ-et-sok*, which could likewise be used for a generic fact, would indicate that the speaker is not very sure. Other examples that I have collected indicate that this notion of uncertainty is due to the fact that the latter form is commonly used when the speaker has not made a personal observation. This can also be seen in the above use of *zer-et-sok* (l. 2) for an abstract generic fact. Other examples, however, show no sign of hesitation or uncertainty.

In a further example, given for the contradictory rhetorical question with *inet* ‘is that so, why should it be so’, the Tagmacikpa speaker used the generalised perfect for a generic observation about another person’s perceptive faculties. In this case, the tone is quite authoritative.

(199) Tagmacikpa (Shamskat, Western Shamma, field data 2019)

ŋaʃ+i ama-s zer-b-at:

we.excl+GEN mother-ERG say-NLS+EX=ASS.HAB

«*ŋa+(·) thoŋ-ba-mi-nuk, ŋa zermo intsok.*»

I+AES see-NLS-NG-VIS=PRS I blind be=GEM

deana jaŋ-gun-is zer-en-uk :

then again/other-PL-ERG say-CNT-VIS=PRS

«*ʃiba zermo in-et? thoŋ-se-intsok, ʃ-aŋ; d-o ma-zer!*»

why blind be-ASS see-LB-GEM=PERF what+FM that-DF NG-say=PRHB

‘Our mother often says: «I can’t see; I’m (kind of) blind.» Then the other people would say: «Why should you be blind? You **do/ can (always) see**, whatever. Don’t talk [like] this!»’

Finally, I also found the following example in my data, with the perfect construction given spontaneously by the informant. (I was looking for the assertive habitual construction *za-at*.)

(200) Tagmacikpa (Shamskat, Western Shamma, field data 2019)

bila-s pitse zos-e-intsok. / ze+(·)n-uk.

cat-ERG mouse eat.PA-LB-GEM=PERF eat+CNT-VIS=PRS

‘Cats eat mice (as is **generally known** / as I have seen).’ (The perfect with the GEM is used for a generic statement; the speaker may or may not have observed a situation like the one described. / The present tense construction with the visual marker indicates that the speaker has seen some such situations, but cannot generalise about all cats.)

The generalised perfect construction is again found with a contradictory, explanatory, or generic function in several dialects across the dialect divide, except in the Purikpa dialects, where only the inferential resultative function is attested.

(201) a. Kyungyampa (Kenhat, Lalokpa, field data 2019)

teŋ ʃhuŋʃhuŋ gun-la lōtʃhog-a so-re-inak,

bird crane winter-ALL south.direction-ALL go.PA+LB-GEM=PERF

da sump-enāa lok-te ho-re-inak.

month third+PPOS return-LB come+LB-GEM=PERF

‘The black necked cranes **go** to the south [to Bhutan or China] in winter, they **return** in the third month.’ (The generalised perfect could be used [by an expert], e.g., by the bird club president. The form might imply that **at least some of the addressees already know** [but it would be new information for others].)

b. Kyungyampa (Kenhat, Lalokpa, field data 2019)

təg tʰuŋtʰuŋ gun-la lōtʰog-a tʰa-ak,
bird crane winter-ALL south.direction-ALL go-FUT.INF
da sump-enāa lok-te hōŋ-kak.
month third+PPOS return-LB come-FUT.INF

‘The black necked cranes go to the south [to Bhutan or China] in winter, they return in the third month.’ (The future inferential would be used by non-specialists; it would also imply that everybody already knows.)

(202) Kyungyampa (Kenhat, Lalokpa, field data 2019)

nima ɛar-ne ɛar-de-nak. / ɛar-hak.
sun east-ABL rise-LB-GEM=PERF rise-FUT.INF

‘The sun rises in the east.’ (The generalised perfect **would be used by a teacher**; it would be especially suitable when uttered **during a practical demonstration**. / The future inferential would be used outside of school, e.g., when talking to one’s nephews and nieces. The speaker would then expect that the children had heard this already in school and thus assumes that s/he only repeats what they already know.)

(203) Gya-Mirupa (Kenhat, Upper Indus dialects, 2022), *Teaching the young to fly*

nəniŋ, ŋə ria rama-un-a mān tāŋ-a(.) doziŋ kher-zane,*
last.year I mountain-ALL goat-PL-ALL medicine give-NLS+ALL oral.vaccine carry-when
ŋātok ŋāmone ŋaŋba daldo tʰaŋma(.) phur-en gjuk-duk.*
morning early goose side all+ALL fly-CNT run-VIS=PRS
fəhat girigiriŋ zer-en daldo tʰaŋma(.) phur-en gjuk-duk.*
bird.sound girigiring say-CNT side all+ALL fly-CNT run-VIS=PRS
ŋaŋba abaam+e tūgu-gun tər-uk.
goose father.mother+ERG child-PL chase-VIS=PRS
ma: ʂante hale jaŋ demo thoŋ-duk-pen.
very very wonderful again beautiful look-VIS-RM=IMPF

tene ŋ+e rarzi-gun-a kāŋfa t̥i-fen. tene rarzi f̥ikf̥ig-e lo :
then I+ERG shepherd-PL-ALL reason ask-RM=ASS.PA then shepherd one-ERG say
«*kh+e tūgu-gun-a phur-fe-a sal lāp-te-inak.*

s/he-GEN/ERG child-PL-ALL fly-GRD-ALL skill teach-LB-GEM=PERF

tetiŋne zak foŋa-zik lāp-te, khoŋ lofoy-a f̥ha-hak» lo.
thereafter day 15-LQ teach-LB they south go-FUT.INF say

‘Last year when I [was] in the mountains in order to give some medicine to the goats and brought up the oral vaccine against worms, in the early morning, the geese were flying quickly in all directions. Making a sound like *girigiring*, they were rushing in all directions. The parent geese were chasing their little ones. That was extremely wonderful and beautiful. Then I asked the shepherds about the reason, and one shepherd said: «They **are teaching** their little ones the skill for flying. Thereafter, when they have taught [them] for about 15 days, they will all go to the south.»’

In this dialect, there is some functional overlap between the generalised perfect and the future inferential. According to the Gya-Mirupa informant, the future inferential (*lāp-kak*, *f̥ha-hak*) is used for generally known facts and habits, the speaker is certain about and which s/he has observed infrequently or a longer time ago. Another future construction based on the gerundive

(e.g., *lāp-tʃe·n*, *tʃha-tʃe·n*) would be used to indicate that one has regularly observed the situation and/ or remembers certain details sharply or also that one has been involved. By contrast, the perfect with the GEM might indicate a lower degree of certainty and a conclusion or realisation by just looking. However, the perfect with the GEM would also be used to indicate that one talks about a fact that everybody knows, and it would be used in an official speech. In the context of the shepherd’s explanation as remembered or presented at the moment of reporting, the motivation may be a combination of explaining a generic fact and at the same time pointing to the current situation. Cf. the explanation of the Faḍumpa informant preceding example (206).

For the Faḍumpa speaker, the perfect construction would be more suitable when discussing the situation with somebody on the same intellectual level, that is, with a person who already knows the fact, while he would prefer the DEPERSONALISED GENERIC KNOWLEDGE MARKER (DPG) to be discussed in the next section (3.4.5), when explaining the fact to somebody who does not yet know. But he also stated that the perfect construction has a more general connotation, independent of whether one actually observes the situation, whereas the depersonalised construction would have a somewhat narrower application, focussing on the items described or also on the particular time (and perhaps also the place) where the situation happens.

- (204) Faḍumpa (Kenhat, Central Zanskarpa, field data 2019)
ṅaṅpa yunka+(·) lofho²-la soṅ-ḍe·no². / tʃha-a·no².
 goose winter+ALL south.direction-ALL go.PA-LB+GEM=PERF go-NLS+GEM=DPG
jar-la lada²-la lo²-te-jō-ḍe·no². / lo²-te-jō-a·no².
 summer-ALL Ladakh-ALL return-LB-come-LB+GEM=PERF return-LB-come-NLS+GEM=DPG
 ‘The geese (generally) go to the south in winter [and] in summer they (generally) return to Ladakh.’ (The perfect construction with the GEM is more general than the DPG-construction. It is more suitable if **the addressee already knows**. / The DPG-construction focuses more upon the particular time or on the presence of the cranes. It is more suitable when the addressee does not yet know, especially in teaching.)

- (205) Faḍumpa (Kenhat, Central Zanskarpa, field data 2019)
nima far-ne far-ḍe·no², nub-ne ʃo-ḍe·no².
 sun east-ABL rise-LB+GEM=PERF west-ABL hon.go-LB+GEM=PERF
 ‘The sun **rises** in the west [and] **sets** in the west.’ (Talking to somebody **who already knows**.)

While explaining how to run a coffee machine, as an example for directions for use, the Faḍumpa speaker switched between the DPG (see next section) and the generalised perfect. When I discussed this usage again with him in 2022, he explained that when giving such instructions for usage, one would commonly start with the DPG, but when getting more engaged and/ or when being in the process of demonstrating in practice, the generalised perfect would automatically be used. This may also happen when describing the usage without actual demonstration, because one would start visualising the process or the different parts of the machine.

- (206) Faḍumpa (Kenhat, Central Zanskarpa, field data 2019/2022)
kofi tʃo-zane, goma+(·) kofi tha²-yøḍ-e·no².
 coffee do-when first+ALL coffee grind-need-NLS+GEM=DPG
te te tha²-kan-bo poṭerfilter-enāa tā-ḍe kofimaʃin-enāa har-ḍe·no²,
 then that grind-NLS-DF porta.filter-PPOS give-LB coffee.machine-PPOS set.in-LB+GEM=PERF

te te+(:)naŋne hay-e ʃaku phiŋ-ɔe-noʔ.
 then that+PPOS:ABL we.incl-ERG tea.water take.out-LB+GEM=PERF
jaŋ maŋin-na lufo tã-ɔe, oma hor-e-noʔ.
 again machine-COM air give-LB milk turn-NLS+GEM=DPG
tene a kab-enãa desain ɔemo ɔemo phiŋ-en-ã kore+(:)nã lug-e-noʔ.
 then that cup-PPOS design nice nice take.out-CNT+COM cup+PPOS pour-NLS+GEM=DPG
ŋeʒ+e izuʔ tã-ɔe-noʔ.
 we.excl+ERG this.way give-LB+GEM=PERF

‘When making coffee, at first, it is necessary to grind the coffee (beans). Then the coffee powder will be put into the porta filter and [the latter] **will be set** in into the coffee machine, [**look!**] Then from that [tap, **look,**] we **draw** the fluid. Then one blows air with the machine and froths the milk up. Then one draws it into the cup with a very nice design. [**Look,**] this is how we **are doing** it.’

Since these usages of the generalised perfect came up only in the last field stay before the outbreak of the corona pandemic, it was not yet possible to check all dialects for this usage. In the following, I add some examples from my earlier research. These examples, which represent explanations and generic facts, have been given for a different research question. The informants thus chose the markers spontaneously.

- (207) a. Domkharpa (Shamskat, Western Shamma, field data 2004)

ʃhit joŋ-na, kheraŋ-a ʃikʃig-is zd^oak-se-intsok.
 sneezing come-CD fam.you-ALL single-ERG prepare-LB-GEM=PERF

‘When you sneeze, somebody **will prepare/ is preparing** [something] for you (as a gift).’ (A **generally believed superstition**.)

- b. Domkharpa (Shamskat, Western Shamma, field data 2004)

sil-ʃas-po pene+(:)ka rag.las-e-intsok.
 study-GRD-DF money+PPOS depend-LB-GEM=PERF

‘The [possibility of] studying (**always**) **depends** on [the availability of] money.’ (A **generally known fact**, concerning education in India.)

- (208) Domkharpa (Shamskat, Western Shamma, field data 2012)

ʃukʃikp-i niʃuya-na zagzaŋ ʃar-e-intsok.
 11th+GEN 25-ABL day.auspicious rise-LB-GEM=PERF

‘From the 25th of the 11th [month] onwards auspicious days **arise**.’ (**Generic knowledge**. These days are considered auspicious, because at that date, the Losar (New Year) festivities start.)

- (209) a. Domkharpa (Shamskat, Western Shamma, field data 2010)

t^eaŋ-ʃas-ʃan-i tshiks-po t^eaŋ-ʃas-ikana (ʃan-izbase) ʃa-se-intsok.
 give-GRD-have-GEN word-DF give-GRD-PPOS:ABL (have-PPOS:INSTR) derive-LB-GEM=PERF

‘The word *t^eaŋʃasʃan* ‘something to be given’ **is derived/ derives** from [the word] *t^eaŋʃas* ‘to be given’ (with the help of [the morpheme] *ʃan* ‘having’).’ (Linguistic **explanation**.)

b. Gya-Mirupa (Kenhat, Upper Indus dialects, field data 2010)

rinfan-e tshik-te rin-ehane (fān-etfere) te-re-inak.

precious-GEN word-DF price-PPOS:ABL (have-PPOS:INSTR) derive-LB-GEM=PERF

‘The word *rinfan* ‘precious’ **is derived/ derives** from the word *rin* ‘worth’ (with the help of the [morpheme] *fān* ‘having’).’ (Linguistic **explanation**.)

(210) Khalatsepa (Shamskat, Western Shamma, 2006), *Village history*, repeated from (177)

Brokpa-s «Brokrgjut intsok» zer-e-intsok. o le.

Brokpa-ERG Brok.lineage be=GEM say-LB-GEM=PERF that HON

‘[**Let me explain:**] the Brokpa (Dards) **have (always) been saying** that [they] are (as everybody in Khalatse knows) of the Brok [that is, Gilgit] lineage. That [is how it is].’ (The first GEM inside the reported speech represents common knowledge, shared by the people of Khalatse. The second GEM in the perfect construction concerning the utterances of the Brokpa is used, as the speaker **explains** a fact to BZ, who, as an outsider, cannot know it, but seems to be interested – initially, she asked how the village came into being, and the speaker then presented the traditional account, see n. 93, p. 103.)

Quite apparently, this explanatory and generic usage of the perfect has been generalised from an inference based on visual input. In this respect, the construction competes with the visual perfect (*V-LB-hdug*). The latter is used for an individual inference based on an individual perception, while the generalised perfect may describe a situation that holds in general. The generalised perfect also competes with the visual present for habits and generic facts outside one’s personal sphere, e.g., when describing that *all* cats in the world catch mice. The visual marker indicates in such cases that the unlimited generalisation is an inference based only on a limited number of perceptions (see Zeisler 2017b/2018a). It may also signal that one observed the habit (once again) just recently, so that the visual impression is foregrounded.

The main difference between the use of the visual present and the use of the generalised perfect for generic facts or habits lies in the communicative attitude towards the addressee. The visual marker emphasises one’s personal realisation of the situation, while the generalised perfect is directed away from one’s personal experience and takes the knowledge state of the addressee and other members of the speech community into account. One wants to explain something and thus to share one’s knowledge with somebody who does not yet know, but one also takes into account that this knowledge is potentially accessible for many more persons.

The following example from a personal narrative concerning childhood memories shows the pivotal point. The informant and her younger sister were in the mountains with the goats. For the informant, at least, it was the first time they went to a particular place. At a certain moment, the goats rushed down a steep slope towards the river, and the informant, not knowing the reason, was utterly afraid, thinking they would fall into the water and drown. She panicked and called out to her sister. The sister looked and then explained that the goats had gone down only in order to drink and that they would come back. I assume that the sister also saw this for the first time, but then perfectly realised what was going on, upon seeing the goats safe at the riverbank and drinking. When telling somebody else, she could have simply used the visual present *fhe-en-uk* or the visual perfect *soṅ-se-duk* ~ *soṅ-se-nuk* for this individual perception. The generalised perfect in the sister’s speech – as remembered or presented by the informant – is motivated by the sister’s attempt to explain and to reassure the informant. It could also be motivated by the fact that the sister is not observing the situation alone (see again section 3.4.1). When discussing the forms of the narrative,

the informant, however, made it clear that, in her understanding, the generalised perfect *sojsein-tsok* ‘have gone’ had the function of an explanation.

- (211) Tagmacikpa (Shamskat, Western Shamma, 2019), *Going with the goats*
than-ijogna sinje ltsanspo rgjug-in-jot-(pin).
 plain-PPOS lion river flow-CNT-EX=ASS.PRS-(RM=ASS.IMPF)
dephia rama-gun fhons-en, det-en,
 therefore goat-PL jump-CNT slip-CNT
fhu thuy-ba+(:) jog-a bap-se-soj, ltsansp+e thama+(:).
 water drink-NLS+ALL below-ALL descend-LB-go.PA river+GEN edge-ALL
rama-gun det-en fha-a thoj-se, na nus-pin,
 goat-PL slip-CNT go-NLS see-LB I cry.PA-RM=ASS.PA
fiba zer-na, <det-e fh+ian but-f+en> sam-se.
 why say-CD slip-LB water+PPOS fall-GRD+CP=FUT think-LB
jan «la, nomo jō-aŋ!» bos-pin,
 again intj younger.sister come-DM call.PA-RM=ASS.PA
«rama-tsak-ni fh+ian but-e-fh+e(:)n-uk» zer-re.
 goat-PL-TOP water+PPOS fall-LB-go+CNT-VIS=PRS say-LB
nomo joj-se, lta-se-nan, rama-ŋun fhu thuy-ba thoj-se,
 younger.sister come-LB look-LB-COM goat-PL water drink-NLS see-LB
«khoz fhu thuy-ba+(:) soj-se-intsok,
 they water drink-NLS+ALL go.PA-LB-GEM=PERF
joj-f+en-ba» zer-en-ak-pin.
 come-GRD+CP=FUT-emp say-CNT-NVIS-RM=IMPF
deana rama tshanma lok-se-jojs. de(:)rtiŋna ŋa-s sam :
 then goat all return-LB-come.PA thereafter I-ERG think=PA
<khoz denatsogz-la det-en-soj-se fhu thuy-et-sok> sam.
 they that.very.way-ALL slip-CNT-go.PA-LB water drink-EX-INF/DST think=PA
 ‘Below the plateau flows the Lion river (Indus). Therefore, the goats went down, jumping and slithering, in order to drink water, [that is, they went down] to the riverbank. [I didn’t understand this and] seeing the goats slipping down, I (started to) cry, because I thought <they would slip and fall into the water>. And I called «hey, sister come!», telling [her] «the goats, [they] are going to fall into the water!» When my sister came and looked, [she] saw that the goats were drinking water and so she explained, «they **are** [simply] gone to drink water. [Don’t worry] they will certainly come back.» And then [in fact], the goats came back. After that [experience], I realised (lit. thought): <[okay,] that way, they drink water after slithering down.>’

In a presentation that I gave in a (certainly not very perfect) Western Shamma version, I drew upon descriptions of routes and travels by the Chinese pilgrim Faxian and others. The talk was tested beforehand with the Tagmacikpa informant, who approved the generalised perfect for citations of these reports, (212). I could have used constructions with the visual marker, if I wanted to present these descriptions only as personal experience of the respective person. However, since all these descriptions were meant as information or instruction for others, the generalised perfect appeared to be more suitable. While based on past personal experience, such reports and descriptions refer to a general situation, still valid at the time of the utterance and beyond.

This explanatory function has also been established in the Gya-Mirupa dialect for attributive and existential constructions. Here again, the visual marker is used for reporting one's personal experience among family members or friends, (213), alternative a., while the generalised perfect construction is used for an official report, presenting generic facts, alternative b.

- (212) Emulation of Western Shamma (with the help of the Tagmacikpa informant, 2019)
lam.phraŋ hjaŋsa-naŋ bragzaŋs-isbase jaŋ-jaŋ fhat-e-intsok lo.
 path.narrow crag-COM precipice-PPOS:INSTR again-again be.cut-LB-GEM=PERF QOM
 'The narrow path **is** again and again **cut off/ interrupted** by crags and precipices, [Faxian] said.' (**Official report.** See Beal 1869: 21: 'Steep crags and precipices constantly intercept the way.')
- (213) a. Gya-Mirupa (Kenhat, Upper Indus dialects, field data 2019)
lam ma: sokpo duk, takzaŋ maŋbo duk-pen.
 road very bad be.VIS precipice many exist.VIS-RM
 'The road was very bad, there were many precipices (as I saw).' (A traveller comes back home and tells his/her family and friends what s/he has experienced.)
- b. Gya-Mirupa (Kenhat, Upper Indus dialects, field data 2019)
lam ma: sokpo hot-e-inak, takzaŋ maŋbo hot-e-inak.
 road very bad be(X)-LB-GEM=PERF precipice many exist-LB-GEM=PERF
 '(**In general,**) the road **is** very bad, [and] there **are** many precipices.' (Giving an **official report**, e.g., to the Hill Council – which may have sponsored the journey. The form implies that the speaker has seen the reported situation.)

I should like to add one more emulation of an official speech by a member of the Snow Leopard Conservancy India Trust, which shows the use of *intsok* in different constructions in the context of an explanation: as a copula, as an auxiliary in a prospective/ gerundive construction, and as an auxiliary in a (generalised) perfect construction. As a copula, *intsok* is used in the introduction for an attribution, namely snow leopards are important and even beneficial for the villagers, a fact that may not be known to the audience, especially not to the villagers who suffer from the snow leopards and who would rather like to eliminate them. The GEM also signals that this claim will be further explained. In the subsequent explanation, the perfect construction describes a generic fact virtually everybody in Ladakh knows or could know, namely that snow leopards eat all sorts of mountain goats. The prospective construction then serves to imagine what would happen if there were no more snow leopards left, which is, of course, the reason why snow leopards are important. This is then again summed up with *intsok* as copula.

There are many awareness campaigns about the snow leopard in Ladakh, so that the informant could easily put herself into the shoes of a project member. Of course, a project member in real campaigns would in most cases use the Central Ladakhi GEM *inok*, and perhaps the DEPERSONALISED GENERIC KNOWLEDGE MARKER (DPG, see next section) instead of the perfect construction. But when the campaigner belongs him/herself to the village where s/he gives the speech, s/he might switch to his/her own dialect.

(214) Tagmacikpa (Shamskat, Western Shamma, field data 2019)

tshanma-la dzu-le.
 all-ALL greetings-hon
derij dika dzom-faz-la ŋa-s rʃan-iskorla zu-in.
 today here gather-GRD-ALL I-ERG snow.leopard-PPOS hum.talk-CP=ASS.FUT
rʃan-is khinti turu sat-e-jot-to.
 snow.leopard-ERG fam.you(incl).GEN animal kill-LB-EX=PERF-PRB
inan rʃan-po ŋati jul-iphia
 but snow.leopard-DF we.incl.GEN village-PPOS
ma: khaktʃen phantokʃen-ʃik intsok.
 very important beneficial-LQ be=GEM
ʃiba zer-na, rʃan-is ridaks-ŋun zos-e-intsok.
 why say-CD snow.leopard-ERG mountain.goat-PL eat.PA-LB-GEM=PERF
galtes rʃan-is ridaks-ŋun ma-za-na,
 if snow.leopard-ERG mountain.goat-PL NG-eat-CD
deana ridaks mana manbo ʃha-ʃa-intsok.
 than mountain.goat ever much become-GRD-GEM
deana ridaks-ŋun-is ŋati rʃsoa tshanma zij tshanma za-ʃa-intsok.
 then mountain.goat-PL-ERG we.incl.GEN grass all field all eat-GRD-GEM
de(:)phia rʃan-ŋun joŋ-go-ʃas ma: khaktʃen intsok.
 therefore snow.leopard-PL come-need+GRD very important be=GEM

‘Greetings to all. Let me talk today to this gathering here about the snow leopard. The snow leopard might have killed your animals. But the snow leopard is very important and beneficial for our villages. The reason is: the snow leopard **eats** the mountain goats (**as all of you might know**). If the snow leopard does not eat the mountain goats, then the mountain goats would become much too much and then the mountain goats would eat up all our grass and [what is on] the fields. Therefore it is very importantly necessary that there are snow leopards around.’ (Emulated official speech in a village gathering for an awareness campaign.)

3.4.5 The Kenhat marker for de-personalised general knowledge -anok ~ -anak (profiling the addressee’s interests and knowledge)

When talking of generic facts in the explanatory mood, speakers of several Kenhat dialects plus the Lingshetpa speaker prefer the DEPERSONALISED GENERIC KNOWLEDGE MARKER (DPG), consisting of verb stem I plus nominaliser plus GEM, the latter two contracted to *-anok* or *-anak* with the negated forms *-a-manok* and *-a-manak* (in some dialects also contracted to *-amak*), see also Table 7 for the negated forms of the GEM. My late host in Leh always used to ask me and I was supposed to answer accordingly:

(215) Lehpa (Kenhat, Central Ladakhi) dialog-type

[A:] *ŋeran-e jul-a ʃi joŋ-a-nok?*
 hon.you-GEN country-ALL what come-NLS+GEM=DPG
nas joŋ-a-nog-a? to joŋ-a-nog-a? –
 barley come-NLS+GEM-QM wheat come-NLS+GEM=DPG-QM

[B:] *ŋaʒe jul-a nas-aŋ joŋ-a·nok,*
 we.excl.GEN country-ALL barley-FM come-NLS+GEM=DPG
ʈo-aŋ joŋ-a·nok. inaŋ ɖas joŋ-a·ma·nok.
 wheat-FM come-NLS+GEM=DPG but rice come-NLS-NG+GEM=DPG

[A:] ‘What [kind of crops] are (**generally**) **growing** (lit. coming) in your country? Do you (**generally**) **have** (lit. does come) barley? Do you (**generally**) **have** wheat?’ – [B:] ‘In our country we (**generally**) **have** barley as well as wheat. But we (**generally**) **don’t grow** rice.’

In the next example, the speaker A first assumes that the addressee might know about the institution of autumn ploughing⁹⁷ and uses the DPG to refer to shared knowledge and a generally known process. As it turns out, B either does not know the particular Zanskarpa expression or does not know what autumn ploughing is. When B thus asks back, A provides an explanation, again using the DPG in its explanatory function. The facts s/he refers to do not belong to his personal knowledge or territory of information.

Because the copula cannot appear in the form of a DPG construction, B asks about the definition with the GEM as copula. B can and does expect that A knows very well what s/he is talking about, but B would also assume that this cannot be A’s exclusively personal knowledge. In formulating the question with the GEM (or with the DPG when possible) B also signals modestly his/her interest to know more details.

(216) Faɖumpa (Kenhat, Central Zanskarpa, field data 2019)

[A:] *zāhar-la θonloʔ taŋ-a·noʔ.* –
 Zanskar-ALL autumn.ploughing give-NLS+GEM=DPG

[B:] *ʈi_ _inoʔ, θonloʔ?* –
 what be=GEM autumn.ploughing

[A:] *θonloʔ zer-kan-bo kyi-ɖe-θiŋbo-ne taŋ-a·noʔ,*
 autumn.ploughing say-NLS-DF threshing-LB-after-ABL give-NLS+GEM=DPG
sa tulmo ʈha-a-la.
 earth soft become-NLS-ALL

[A:] ‘In Zanskar, [one] **performs** the autumn ploughing (**as is generally known, and you might also know**).’ – [B:] ‘What is this, autumn ploughing? (Please explain.) – [A:] ‘(Okay, **I’ll explain**;) the so-called autumn ploughing **will be performed** after threshing, so that the earth becomes soft/ loosened up.’

In the Teyapa dialect of Eastern Sham (which is practically sandwiched between the Shamskat dialects and the Central Ladakhi Kenhat variety), a similar construction can be found for facts that are generally known, but which may not necessarily have been observed personally. The negation, however, differs from the Kenhat construction, in that the negation marker *mi* precedes the main verb. (With the negation marker *mi*, the construction also differs from the negated perfect *ma-V-NLS-Aux*, cf. n. 95, p. 109.)

⁹⁷ This kind of ploughing after harvest is found in many regions, except those where the soil contains too many stones, as in Gya-Miru. Most Ladakhis could thus be expected to know what speaker A is referring to, although they might not recognise the term, which varies from region to region, and they might not know that autumn ploughing is performed also in Zanskar.

(217) Teyapa (Shamskat, Eastern Shamma, field data 2018)

jumbog-is sa dzambo fha-fuk-pa·nok, inaj mi-dak-pa·nok.
 elm.tree-ERG hair soft go-cause-NLS·GEM=DPG but NG-clean-NLS·GEM=DPG
 ‘(Let me explain that, as generally known,) the [bark of the] elm tree **makes** the hair soft, but [it] **does not clean** [it].’

The DPG construction is very prominent in the Lehpa dialect, so that it is spreading and is inadvertently taken up by speakers from dialects where it does not belong to (when asked about it, these speakers may correct themselves and reject the construction explicitly). Western Shamma speakers, e.g., would use either the neutral gerundive construction V-GRD-*yin*, if they have personally observed the situation, or the inferential construction V-EX-INF/DST, when their knowledge is less immediate. When reporting about the World Migratory Bird Day celebration, the Tagmacikpa informant first used the DPG, as used by the original speakers, and when asked about this, replaced it with the said inferential construction (this replacement is marked by “>>”):

(218) Tagmacikpa (Shamskat, Western Shamma, 2019) *Migratory Bird Day*

deana «ifu-i phantoks ma: manbo jot-sok» lo.
 then bird-GEN benefit very many exist-INF/DST QOM
 «*modi rahul-gun-is tsam-fik phantoks tan-et,*
 Modi Rahul-PL-ERG how.much-LQ benefit give-EX=ASS.PRS
de-san man-a ifu-ηun-is tan-a-nok >> tan-et-sok» lo.
 that-CNTR be.many-NLS bird-PL-ERG give-NLS-GEM=DPG give-EX-INF/DST QOM
 «*ifu-ηun-is zih-un-ika butsik ga-ηun-is notskjal tan-et,*
 bird-PL-ERG field-PL-PPOS insect what-PL-ERG damage give-EX=ASS.PRS
de butsik-tsak khō-un-is za-a-nok >> ze-t-sok» lo.
 that insect-PL they-PL-ERG eat-NLS-GEM=DPG eat-EX-INF/DST QOM
 «*jikṛten-ian mi lak sum i-a-nok >> fi-t-sok» lo.*
 world-PPOS person 100,000 3 die-NLS-GEM=DPG die-EX-INF/DST QOM
 «*ifia zer-na, butsik sat-fas-i sman-na fozma lut-izbase.*
 why say-CD insect kill-GRD-GEN medicine-COM artificial manure-PPOS:INSTR
de(:)fia ifu-ηun ma: khaktfan intsok» lo.
 therefore bird-PL very important be=GEM QOM

‘Then [he, the director of the Snow Leopard Conservancy India Trust] said «there are very many benefits [coming from] the birds.» [He] said, «the birds **give** more benefits [to the people] than the many benefits that Modi and Rahul and all [the politicians] are giving.» [He] said, «the birds **eat** those insects that cause damage on the fields.» [He] said, «300,000 persons **die** [per year] everywhere, because of insecticides and artificial manure. Therefore the birds are very important.»’

The Central Ladakhi DPG is the most neutral form for generic facts and their explanations, but cannot be used in this neutral function for individual facts. With individual facts, it can only express an assumption, and in such cases, the DPG betrays its origin from an epistemic marker for presumptions.

- (219) Lingshetpa (Shamskat, Southern Shamma, field data 2016)

ʃiba ʃhugu ʃhu ʃajm+enəŋa duk-ʃhug-et?
 why child water cold+PPOS stay-let-EX=ASS.PRS
kho-a traŋmo ʃha+(:)+nok-pa! / ʃh+et-pa!!
 s/he-AES cold go+NLS+GEM=DPG-emp go+EX=ASS.PRS-emp
 ‘Why do you let/ make the child stay in the cold water? S/he is (**presumably** / definitely) going to get cold!’ (The first alternative with the GEM is **more neutral**. / The second alternative is more alarmed.)

In the above example, the GEM has a double function. On the one hand, it indicates an assumption, on the other, it makes the expression more neutral, whereas the non-experiential marker shows the speaker’s alarmed attitude. In the next examples, we deal only with the assumptive function.

- (220) Lehpa (Kenhat, Central Ladakhi, second generation, field data 2017, *Kesar*, elicited)

tene meme+(:) zer-kjak : / ʃilan taŋs-kjak :
 then grandfather+ERG say-DST answer give.PA-DST
 «*ŋ-e ʃŋanpa thob-a-nok sam-te, jak-po ma-sat-pin.*»
 I+ERG reward obtain-NLS+GEM=DPG think-LB yak-DF NG-kill-RM=ASS.PA
 ‘Then the old man said: / gave the [following] answer: «I didn’t kill the yak in order to (lit. with the idea that I **would/ might**) **obtain** a reward.»’

- (221) Rumbakpa (Kenhat, Central Ladakhi, field data 2017)

ŋa thore koaʃ-la ʃh+et. tene tasil ofisla ʃh+et.
 I tomorrow court-ALL go+EX=ASS.PRS/FUT then tehsil office-ALL go+EX=ASS.PRS/FUT
testiŋne boaq ofis-la ʃh+et. sukul-a soŋ-te
 thereafter board office-ALL go+EX=ASS.PRS/FUT school-ALL go.PA-LB
maigreʃen seʃifiket-po khjoŋ-et. tene tshan ʃha+a-nok.
 migration certificate-DF bring-EX=ASS.PRS/FUT then night go+NLS+GEM=DPG
 ‘Tomorrow, I’ll go to the court. Then I’ll go to the tehsil office. Thereafter, I’ll go to the [education] board office. [Then] when I’ve been to the school, I’ll get (lit. bring) the migration certificate. Then, (**most probably**), **it is going to be** night.’

- (222) Çarapa (Kenhat, Upper Indus dialects, field data 2016)

khjore kho-a pēne ʃuun-zik mane mā-taŋ-na,
 you.self.ERG s/he-ALL money few-LQ except NG-give-CD
kh-e le ʃʃē-a-ma+nak. / ʃʃē-ʃʃe-man.
 s/he+ERG work do-NLS-NG+GEM do-GRD-NG.CP=FUT
 ‘S/he won’t work (I **suppose** / we know), if you give only a small amount of money.’

One can see a similar, yet still incomplete, development from a future inferential to a depersonalised generic marker in other Kenhat dialects. The future inferential based on the nominaliser *ka* plus GEM *-ka(na)k* (<*ka-yin-ħdug*), negated *-kama(na)k* (<*ka-ma-yin-ħdug*) is also very frequently used for well-known habits outside one’s personal sphere or for generic facts, cf. also example (203), p. 114. In example (223) a., the future inferential is used to express a mere expectation, based on earlier experiences. In version b., the future inferential expresses a generic fact that is potentially known by all villagers. The speaker defocuses from his/her own personal experience. By contrast, the neutral future (GRD+*yin*) implies that the speaker bases his/her statement on his/her own (repeated) personal experience (or, when applicable, also on his/her personal involvement).

- (223) a. Gya-Mirupa (Kenhat, Upper Indus dialects, field data 2019)
(kalter) tɛ nāmbu tshaŋma tshoŋ-na, kho-a pēne maŋbo thop-kak.
 (if) that (s)nambu all sell-CD s/he-AES money much get-FUT.INF
 ‘If s/he sells all this (s)nambu (woollen cloth), s/he will/ should/ might get a lot of money.’
- b. Gya-Mirupa (Kenhat, Upper Indus dialects, field data 2019)
naŋ-zik kha (maŋbo) tāŋ-na, kīn ridak tshaŋma
 when-LQ snow (much) give-CD ibex mountain.goat all
jul-a pap-te-ŋoŋ-gak. / pap-te-ŋoŋ-ŋ-en.
 village-ALL go.down-LB-come-FUT.INF go.down-LB-come-GRD+CP=FUT
 ‘Whenever it snows (a lot), the ibexes and mountain goats come down to the village (it is always like this, because it is natural / and I observed it many times).’

3.4.6 Use of the DPG for first person habits and planned activities

Maaz Shaikh, a PhD student at the University of Alberta, who started fieldwork on the Zanskarpa dialects, kindly showed me his field notes in 2022. Among them was a sentence containing the DPG for a first person inclusive plural, unfortunately without further context. This seemed to be weird, but the Faḍumpa informant confirmed that the DPG, in fact, could be used infrequently for a habit in explanations, as in example (224). He further described the use of the DPG when summing up a discussion about further actions and particularly when summing up negotiations about jobs, example (225). Decisions can be questioned in an apparently lighter manner by using the DPG, example (226). The Faḍumpa informant further produced the DPG spontaneously in his account of his first cigarette, where it indicates immediate regret and has a persuasive function, example (227).

- (224) Faḍumpa (Kenhat, Central Zanskarpa, field data 2022)
 [A:] *ta fi ze-en-nu?* sonam-a ɕaŋ leha ʃo-ʃu²-taŋ-du²?! –
 now what say-CNT-VIS=CNT.PRS Sonam-ALL always work do-let-give-VIS=PRS
 [B:] *te fi? haŋ+e / ŋaɜ+e / ŋ+e kho-a pene tā-e-no?*
 then what we.incl+ERG we.excl+ERG I+ERG s/he-ALL money give-NLS-GEM=DPG
ʃonla ʃo-ʃu²-tā-a-ma?
 in.vain do-let-give-NLS-NG.GEM=DPG
 [A:] ‘Now, what are you saying?! You always make Sonam work (as I see)?!’ – [B:] ‘So what? (you **know well/ should understand** that) we (inclusive you) / we (exclusive you) / I (**always**) **give** him/her money; [and s/he] **is not made to work** for nothing.’
- (225) a. Faḍumpa (Kenhat, Central Zanskarpa, field data 2022)
haŋ+e ʃugu naŋmo ʃuifen-la tā-e-no?
 we.incl+ERG child next.year tuition-ALL give-NLS+GEM=DPG
 ‘[**So then,**] we **will send** the child(ren) to tuition next year.’ (The DPG can be used for **summing up** a discussion, indicating that **the information is not new** for both speaker and addressee. However, the DPG seems to be less common when summing up a discussion within a family, than when negotiating with an outsider, cf. version b.)

b. Faḍumpa (Kenhat, Central Zanskarpa, field data 2022)

tene ŋaʒ+e / ŋ+e thore-nephala

then we.excl+ERG I+ERG tomorrow-PPOS:ABL

kheraŋasa+(:) thugu tuiŋen-la taŋ-e-nog-ii.

fam.you.place+ALL child tuition-ALL give-NLS+GEM=DPG-intj

‘So then, from tomorrow onwards, we / I will send the child(ren) for tuition to your place, all agreed!’ (The DPG **sums up the negotiation**, the interjection *-ii* is used to make it sure.)

(226) Faḍumpa (Kenhat, Central Zanskarpa, field data 2022)

[A:] *hay+e thugu-gun tundupsa+(:) tuiŋen-la tã-en.* –

we.incl+ERG child-PL Tundup.place+ALL tuition-ALL send-CP=ASS.FUT

[B:] *khosa-a fi tã-e-noʔʔ*

s/he.place-ALL what send-NLS+GEM=DPG

kho-ni fup+eʔ mane sil-de-maʔ. –

s/he-TOP 10th+LQ ever study-LB-NG.GEM=PERF

[A:] *fi zer-e-in waʔ! kho-ni koledz-la soŋ-de-noʔ!*

what say-LB-CP=ASS.PERF intj s/he-TOP college-ALL go.PA-LB+GEM=PERF

[A:] ‘We will send the children to Tundup for tuition (as I decided).’ – [B:] ‘Why **sending** [them] to him? (**Can you give a reason?**) He has studied only up to 10th class (as you know).’ – [A:] ‘What are you saying? He has been to college (as everybody knows)!’

In this case, the DPG has two functions in opposition to the assertive future construction *tãen*. The assertive future construction in A’s statement implies a decision. B’s question concerns the potential teacher and his ability, which **fall outside of the territory of information** of both speaker and addressee, hence the use of the DPG. According to the informant, the assertive future construction would be suitable only, if the question had been about the children’s need for tuition, a question that falls inside the parents’ territory of information. Nevertheless, the future construction could be used by B, if s/he were absolutely convinced about the non-qualification of the potential teacher. S/he would then claim better knowledge from his or her territory of information, and the statement would implicate a decision on his or her part. By using the DPG, B signals, according to the informant, that s/he **does not want to impose his/her opinion** on A [and is thus still open for further discussion]. The perfect with the GEM *sildemaʔ* and *soŋdenoʔ* indicates both B’s and A’s firm convictions about facts that fall outside their respective territory of information.

(227) Faḍumpa (Kenhat, Central Zanskarpa, 2022), *The first cigarette*, repeated from (102)

tsuntse-zane, ŋa+(:) afo sigreṭ thũ-la thoŋ.

be.small-when I+AES elder-brother cigarette drink-FM see=PA

tene khø-e ŋa lyi-de kher-de ŋa-la thuŋ-fi ta, tsawi-fi.

then s/he+ERG I placate-LB take.away-LB I-ALL drink-LQ give=PA a.bit-LQ

tekane khøe lo : «ta ma-thuŋ-wa! jafa fjoe-tã-e-noʔʔ» lo. /

thereafter s/he+ERG say now NG-drink=PRHB-emp fun do.PA-give-NLS+GEM=DPG QOM

«... *jafa fjoe-de-in» lo.*

fun do.PA-LB-CP=PERF QOM

«*ta ŋa-la thuŋ-ŋe-maʔ, kherã-la thuŋ-ŋe-maʔ.*

now I-FM drink-GRD-NG.GEM fam.you-FM drink-GRD-NG.GEM

jaŋ θiŋne thu-a thoŋ-ne, duŋ-en» lo.

again afterwards drink-NLS see-CD beat-CP=ASS.FUT QOM

‘When I was small, I [once] saw my elder brother smoking. Then he took me along, placating me, and let me take a draw, a little bit. Thereafter he said: «Now don’t smoke/ stop smoking, hey! [I] **was [only] making fun**, right? / ... [I] definitely [only] made fun.» [He] said «Now, I shan’t smoke [and] you shan’t smoke either. And [I]’ll beat [you], if [I] see [you] smoking later on.»’

Here, through the contrast with the assertive perfect construction *f̥øedein*, which would present the situation sincerely, the DPG construction *f̥øetäeno*⁷ indicates that the speaker becomes aware of the inappropriateness of his/her action and regrets it. At the same time the form also seems to signal that the claim about the situation (having made only fun) is not really true, and that it is a mere suggestion to treat it as true. It may thus have a persuasive connotation.

3.4.7 Other usages for the speaker, carrying a special emotional load

Some speakers may use the DPG construction also for their own activities, in order to indicate some kind of self-distance combined with a higher emotional load, signalling, e.g., defiance or pride.

(228) Rumbakpa (Kenhat, Central Ladakhi, field data 2017)

[A:] *o:*, *kheraŋ zaktaŋ phumet gon-duk!* –
intj fam.you every.day *phumet* wear-VIS=PRS

[B:] *ŋa zaktaŋ gon-et.* / ***gon-a+nok.***
I every.day wear-EX=ASS.PRS wear-NLS+GEM=DPG

kheraŋ pata jot: *ŋa sŋonla-aŋ gon-a+nok.*
fam.you knowledge have.ASS I earlier-FM wear-NLS+GEM=DPG

[A:] ‘Oh, you always wear a *phumet* (a Tibetan style sleeveless dress) (as I see)!’ – [B:] ‘[Yes,] I always wear [it]. (Neutral statement.) / [**So what, / What do you want,**] I **always wear** [it]! You know it well: I **have been wearing** it also earlier [so **stop commenting**].’ (The speaker shows his/her embarrassment and his/her will to stop further comments.)

(229) a. Faḍumpa (Kenhat, Central Zanskarpa, field data 2019)

[A:] *tsam-fi*² *sigreŋ thuŋ-e-in!* –
how.much-LQ cigarette drink-NLS-ASS

[B:] *te ŋ-e thuŋ-e-no*²!
then I+ERG drink-NLS+GEM=DPG

[A:] ‘How many cigarettes you are smoking!’ – [B:] ‘So then, I **am smoking** them [**what’s your business**, I am paying it myself]!’

b. Faḍumpa (Kenhat, Central Zanskarpa, field data 2019)

*thore ŋ-e de mi-la ḍuŋ-e-no*².
tomorrow I+ERG that person-ALL beat-NLS+GEM=DPG

‘Tomorrow I’ll **beat up** that man!’ (The speaker is **boasting**.)

Similar uses may also be observed with the GEM alone, cf. examples (151) and (152) in section 3.3.9.

4 Discussion

The Ladakhi GENERALISED EVALUATIVE MARKER or *inok* & siblings come in many forms and with even more different functions, most of which they all share. While the original function of both the Kenhat element *-ok/-(d)ak* and the Shamskat element *-suk/-sok* is of an epistemic nature, in many applications, this epistemic nature has bleached out or has been exploited for socio-pragmatic functions. Some of these pragmatic functions may be likened to those of the ‘factual’ copula *red* in Central and East Tibetan. While not all functions described above are attested in all dialects or accepted by all speakers, it is clear that the GEM cannot be reduced to its elements and to the original epistemic function of the second element, but must be taken as a compound with its own multiple functionality. Given its epistemic *and* pragmatic (non-epistemic) functions, it can be analysed neither as an epistemic marker nor as a neutral form. In the system of the Ladakhi evidential-*cum*-attitudinal markers, it has its place in the main slot for the non-committed attitude. There are both knowledge-based and socio-pragmatic reasons for its usage.

The knowledge-based reasons are: the situation does not belong to the MSAP’s personal sphere or territory of information and/ or the MSAP has not immediately observed the situation, so there is also a reasoning process involved, as in the case of identification via sense perception, inference, and sudden realisation.

The socio-pragmatic reasons include notions of politeness or humbleness, but also overtones of pride and challenge. They also include notions of compassion and notions of rights and responsibilities: one does not want to, or does not dare to, or is not allowed to, present a certain fact as personal knowledge (whether intimate personal knowledge, personal observation, or personal inference) even if it is personal knowledge. This restriction applies particularly to generic knowledge that is shared with the whole speech community or knowledge that is already shared between speaker and addressee, e.g., through co-participation or co-observation, but this attitude is also found in most dialect regions when the speaker shares information, under open license, so to speak, with the addressee who does not yet know. In the latter case, this explanatory attitude corresponds to a friendly invitation to participate in the knowledge.⁹⁸ It also signals one’s readiness to give more details or one’s openness for debate. The addressee thus feels more at ease to participate in the discussion and to ask for more details.

Apart from this, the GEM also has modal values, when it is used for requests or suggestions and when it is used in the western and southern Shamma dialects for other irrealis situations or even for counter-expectations. These situations equally fall out of the MSAP’s personal sphere, because of being imaginary, on the one hand, or unexpected, on the other.

If one seeks for a unified function of the GEM that underlies all its applications, I should call it epistemic *and* socio-pragmatic hedging or downgrading. It refers to situations and facts that fall out of the MSAP’s (extended) personal sphere or territory of information, because these situations and facts are neither private nor personally observed. They may be merely inferred or assumed or, when talking about shared and shareable knowledge or triggered by other pragmatic considerations, they are *presented as if* merely inferred or assumed.

⁹⁸ I should like to point again to the fact that this idea about an *invitation* to participate in, or to share, knowledge stems from a talk by, and the subsequent discussion with, either Diane M. Hintz or Daniel J. Hintz, most likely the former, at the conference *The Nature of Evidentiality 2012*, Leiden University.

This as-if stance may be compared to socio-pragmatic usages of modal forms and modal verbs in the Standard European languages in the context of uttering wishes, such as *I would like to have*, *je voudrais*, *ich hätte gerne* instead of *I want*, *je veux*, *ich will*. In this context, the speaker has no doubts about his or her wishes, but presents them *as if* having them. This may have been eased by the speaker's doubts about the socio-pragmatic suitability of uttering a wish, which is, nevertheless, no longer an epistemic assessment of having a wish. Furthermore, as soon as such usages are conventionalised, the original meaning of epistemic hedging is completely lost. One uses such phrases as set formulae.

In a similar manner, no Ladakhi speaker thinks about inferences when making a generic statement with the GEM, nor do they think of generic facts when they express an inference with the same form. And when they talk about items that do not belong to their personal sphere, they neither have the feeling of making an inference, nor do they necessarily think about generic facts, they simply think this does not belong to me or I do not belong to them or this is theirs, not mine.

One may perhaps object that the pragmatic usages are merely metaphorical extensions of an originally epistemic or even evidential function of *inok* & siblings. The use in irrealis contexts, however, makes it unlikely that the original function was either inferential or experiential. It is more likely that the original function was simply non-confirmative, and that the use for inferences, first perceptions, and irrealis contexts are subfunctions of the non-confirmative, admiring stance. From a synchronic perspective, however, the metaphorical extensions have become pragmatic functions in their own right; to the extent that it becomes difficult to construct a semantic link, e.g., between the erstwhile hedging function and the 'factual' generic usage.

4.1 *A note on origins*

There are two possible approaches for dealing with this mixed bag of functions. From a short-term diachronic perspective, one might argue that the multiple functions of the GEM would neutralise its original epistemic value. The examples might be interpreted as demonstrating how an epistemic function of, say, inference or assumption is generalised to the extent that it is shifted to the background and secondary functions of epistemic downgrading are exploited for pragmatic downgrading.

From a long-term diachronic perspective, I should suggest that all four main functions described above result from an earlier admiring or non-confirmative value of *hdug*, which it acquired at some time in the development of the Tibetan language(s), possibly at some transitional stage between Old and Middle (i.e., Classical) Tibetan. This admiring value comprised inferences by reasoning and assumptions or guesses, as well as first, unsettled perceptions, including misperceptions, of *any* person, speakers and third persons alike (Zeisler 2018b). One may infrequently also come across the use of *hdug* for merely imagined situations, including counterfactuals (see example (230) below). By using *hdug* or the *par-hdug* construction, the speaker (or author) presents a situation as preliminarily true or as only appearing to be true for the moment. This attitude may well have had pragmatic applications in the spoken language. Given the hierarchical nature of the Old Tibetan society, one could rather expect that subaltern speakers were obliged to make use of the admiring *par-hdug* construction, in order to downgrade their respective epistemic stance. However, such usages seem to be too infrequent in the written genres to become apparent.

My approach stands in contrast to that of those authors who suggest that the experiential meaning of *hdug* developed straightforwardly from its lexical meaning 'sit' (or rather 'stay'). Volkart

(2000: 143) suggests that the evidential use of the verb *hdug* could have developed from its basic meaning ‘stay, be located’ in such a way that a statement about the location of an item could become an assertion that *it is located before my eyes*. Similarly, Mélac (2014: 435) suggests, that *hdug* would first of all have referred to a particular posture, namely sitting, after which it would have developed the meaning of a concrete positioning, that is, to be located, from which then the meaning of direct perception would have evolved. Like Zemp (2017: 614 and passim), Mélac thinks that the ‘egophoric’ meaning of *yod* developed only when *hdug* had become de-categorised and had developed the tendency to refer to third persons in most contexts. Rev1 apparently sympathises with this analysis. For him *hdug* could only have had an evidential, that is, experiential notion, and the *-par-hdug* construction would thus have been an extension.

The problem with this approach is that *hdug* did not originally refer to anything distantly related to sense perceptions, so that one could not say that the admirative function was an extension of the perceptive function, as in the case of English *I see* becoming *I understand*. The meaning of *hdug* as a lexical verb is perdurative ‘stay’, that is, the temporally limited being located at a certain place. If this meaning is extended metaphorically for an identification, then it should be interpreted as *for the time being X appears to be Y* or *X looks like Y – but in the end, this may not be the case*. It can hardly mean *I perceive that X is Y (and I have no doubts about this)*, because the abstract identity relation cannot be seen; it can only be inferred if not known from beforehand.

Direct sense perception of existential and spatial relations is of course possible, and the above argument might be rescued in saying that the metaphoric extension of ‘stay’ first applied only to existential and spatial relations and that only in a second step it was further extended to identity relations. But in the case of existential and spatial relations, the early Classical Tibetan data shows that *hdug* was applied only for first, unsettled perceptions, including misperceptions. And since these unsettled perceptions were commonly ascribed to narrated third persons, *hdug*, in all likelihood referred to something that belonged to the side of the object of the perception rather than to the side of the speaker (and his/her subjective perception). Therefore, these earliest occurrences of *hdug* as an existential linking verb should be translated as *(for any observer N,) X appears to be at Y* or *(for any observer N,) at Y, there appears to be an X – but in the end this may not be the case*. One may then prefer to call this function of *hdug* ‘apparentative’ rather than admirative, but this is only a question of naming, not of definition or analysis.

In this connection, it is interesting to note that it is the inferential and assumptive function of the *par-hdug* construction that shows the first restriction and shift from the object(ive) side to the subjective side of the speaker or MSAP, as the only person making the inference and assumption. For first sense perceptions, this restriction and shift comes much later. Additionally, there is no evidence available that *hdug*, either alone or in the complex *-par-hdug* construction, had an exclusively experiential meaning before the attested appearance of the admirative usage.

Note also that there was no formal counterpart **-par-yod*. The *-par-hdug* construction stood directly in functional opposition to *yod* and *yin*, which both had an assertive, confirmative, factual function, which they preserved throughout the centuries. This makes it unlikely that *hdug* as a plain linking verb developed its epistemic (or if one prefers: experiential) meaning in direct contrast with *yod*. It is even possible that it was exactly the contrast of the *-par-hdug* construction with *yod*, that lead to a meaning shift from a lexical verb ‘stay’ to an existential linking verb ‘exist, have’ with epistemic connotations.

Finally, it seems to be not very likely that the meaning of *hdug* would shift directly from *stay* to *as I see* and that it would subsequently be extended to *as it appears (for all)* only to be reduced

again to *as I see*. For the opposite direction of the development that I suggest, namely *stay* > *as it appears (for anybody)* > *me thinks* > *as I see*, the Tibetan languages actually have a parallel in the development of the verb *snay* ‘shine, appear’ > ‘seems, appears as’ > ‘be possible/ probable’ and ‘as I see’, as described in Zeisler (2017a).

Whatever the exact origin, around the 15th century, one may observe both the beginning grammaticalisation of *hdug* and a shift away from its broad admirative function to the marking of knowledge based on immediate sense perception only of the speaker or the main speech act participant (Zeisler 2018b). However, the Ladakhi data shows that not only the inferential and epistemic functions survived in reduced forms of *hdug* (and *snay*), but also the irrealis functions. While the Shamskat inferential-*cum*-distance marker *-suk/-sok* combines most of these functions, these functions are distributed over different markers in the Kenhat dialects: the mirative distance marker *-suk/-sok* for the mirative function, the distance markers *-kj-ak*, *-k(an)-(d)ak*, or, in some dialects, the mirative distance marker for the irrealis function, and the element *-ok/-uk/-ak* for inferential and assumptive functions. The inferential values of the second element of the GEM: *-ok/- (d)ak* and *-suk/-sok*, and particularly the irrealis function of the element *-suk/-sok* can thus be seen as an inheritance from the broad admirative functionality of the verb-(*par*)-*hdug*-construction in Classical Tibetan (Zeisler 2017a).

For the irrealis function, compare the following example from the *Mi.la.ras.paḥi rnam.thar*. Repeatedly, Mi.la has been thrown out of the assembly by his *guru*-to-be Mar.pa, because he had no gift to offer. Dejected, Mi.la ponders about what to do. When in his earlier life he performed black magic, he obtained some gold as payment, but now that he performs religion, he is without any riches. He goes on thinking that if he still had only half of what he had obtained for his evil deeds he could now ask for teachings. The first *-par-hdug*-construction thus corresponds to a counterfactual: *if only there were x (gold) there would be y (teachings)*. The second *-par-hdug*-construction contains an assumption, based on what Mi.la had to experience, namely that this particular *lama* will not give him the teachings without a payment or a gift. The third *-par-hdug*-construction refers again to a hypothetical situation. Mi.la wonders whether it would be possible to go back to his village although, or perhaps even because, he had devastated it through his magic spells.

- (230) *Mi.la.ras.paḥi rnam.thar* (de Jong 1959: 68, ll. 5–7, 10–12)
- | | | | | |
|------------------|---------------------------------|---|-----------------------|-------------------|
| <i>ṣdig</i> | <i>byed.dus-kyi</i> | <i>gser de+ḥi</i> | <i>phyed.tsam-žig</i> | <i>yod-na-ḥaṅ</i> |
| evil.deed | do.time-GEN | gold that+GEN | half.about-LQ | have-CD-FM |
| <i>dbaṅ-daṅ</i> | <i>gdams.ṅag</i> | <i>thob-pa+r-hdug-ste</i> | | |
| initiation-COM | instruction | obtain-NLS+LOC-ADM-LB | | |
| <i>da</i> | <i>bla.ma ḥdi+s-ni</i> | <i>ḥbul.ba med-pa+r</i> | | |
| now lama | this+ERG-TOP | gift NG.have-NLS+LOC | | |
| <i>gdams.ṅag</i> | <i>mi-gnaṅ-ba+r-hdug</i> | | ... | |
| instruction | NG-hon.give-NLS+LOC-ADM | | | |
| <i>yaṅ</i> | <i>phyug.po chen.po-žig-gi</i> | <i>g'yog byas-pa+ḥi</i> | <i>gla</i> | <i>bsags-nas</i> |
| again rich | big-LQ-GEN | servant do.PA-NLS+GEN | wages | collect-ABL |
| <i>chos</i> | <i>žu-ba+ḥi</i> | <i>rgyags.yon.ḥdra</i> | <i>ḥbyor-ram</i> | |
| religion | request-NLS-GEN | provision.reward.like | obtain-QM | |
| <i>yaṅ.na</i> | <i>las ṅan.po+s</i> | <i>mthu thoṅs-yod-pa+s</i> | | |
| or | deed bad+INSTR | magic be.able.to.send-EX=PERF-NLS+INSTR | | |

yul-du *phyin-run* *chog-pa·r-hdug* | ...>

village-LOC go-whether be.suitable-NLS·LOC-ADM

‘[I thought] ‘If I had only about half of that gold [that I had] at the time of performing bad deeds, I **would get** initiation and instruction. [But] now **it appears as if** this lama **won’t give** instructions without a gift. ... [Would it be possible that] after having collected wages for having worked as a servant for an important rich [man] I [might] obtain some kind of provisions to offer [as payment] for requesting the religious teachings? Or **might it be in order** to go into [my] village after/ because I had been able to cast magic by my bad karma? ...’

Based on the admirative inheritance, the GEM has a strong attitudinal value of non-confirmation or non-commitment, which makes it the obligatory counterpart to the assertive markers (*yin* and *yod*), the experiential or perceptive markers (*hdug* and *rag*), and the other evaluative markers. Given this contrast, all the latter markers have their own attitudinal values that go beyond ‘mere’ evidentiality. One cannot tease apart the evidential and the attitudinal values of the whole system or one misses the reason for its deeply rooted pragmatic flexibility.

One can also observe that the generalised functions are more common with the use of the copula as a linking verb than with its use as an auxiliary for the complex tense constructions. This is most evident in the Ciktanpa dialect, where the perfect construction with the GEM has a generic function only when used as linking verb (i.e., *joteintsuk*), but never (or hardly ever) when used as an auxiliary in perfect constructions (*V-LB-intsuk*). Similarly, in the Kargilopa dialect, the GEM only very infrequently has a generic function when used in gerundive constructions (*V-GRD-intsuk*). The Purikpa data clearly shows that, whatever the exact origin of the generalised functions, the epistemic-inferential function is the first to spread to the more complex constructions.

The difference between auxiliary use and basic copulative use further reflects the general development of the evidential-*cum*-attitudinal auxiliaries in Tibetan. The dichotomy between *yod* and *hdug* developed first for their use as existential linking verbs, exploiting their inherent temporal values: indefinite and/ or temporally unrestricted existence (*yod*) vs. perdurative or temporally restricted location (*hdug*) becomes extended in use for generally valid facts (*yod*) vs. merely preliminarily valid observations and inferences (*hdug*). Only in a second step was this opposition extended to the auxiliaries of the present tense and present perfect constructions, while it would take further steps to arrive at the full-fledged modern systems, not all of them fully completed. I cannot thus agree with Zemp’s (2017: 613) analysis, reiterated in Zemp (2018: 14–27),

that it was in resultative constructions that *yod* first became contrasted by *’dug* *‘was there’, facilitating the reanalysis of two evidentially opposed existential copulas. Hence, the factual meaning of *yod* formed in contrast to testimonial *’dug*.

Zemp’s scenario is correct only with respect to the development of the inferential markers, such as Purikpa *-suk* or Kenhat *-tok/-tuk* out of a perfect construction with *hdug*. But this development could have taken place only on the base of a pre-developed marked function of *hdug* (epistemic or rather admirative or non-confirmative) in opposition to a confirmative and non-epistemic/ non-experiential or neutral and factual function of *yod*. When this opposition became fundamental for expressing one’s attitude, the speakers had to look for a strategy for downgrading in the context of identity relations. One strategy, apparently, was to look for a suitable verb that could be used like a copula: resultative *red*. Another strategy was to combine the copula with the admirative marker resulting in the form *yin-par-hdug* or shortly *yin-hdug*.

It has been argued that evidential distinctions first develop in past tense contexts (Aikhenvald 2004: 261, 264–266). It has been further suggested that “[a] form which explicitly indicates direct evidence can only exist in opposition to one or more which expresses indirect evidence”, so that “the existence of a direct evidential form depends on the contrast with an indirect form, and the two forms divide up the semantic space between them” (DeLancey 2012: 544; similarly de Haan 2012a: 1026/ 2012b: 6 for hearsay marking; Aikhenvald 2004: 40f. for non-first-hand). The Tibetic data yields quite a different picture. The opposition starts with the existential linking verbs *yod* and *hdug*. This is neither an opposition between ‘direct’ and ‘indirect’ (or firsthand and non-firsthand) nor an opposition between ‘egophoric’/ non-experiential and experiential, but an opposition between commitment or confirmation and non-commitment or non-confirmation. This opposition then spreads to the auxiliaries of present time reference (including habits, generic facts, and the present perfect) before also fully affecting the copula. This is certainly not just a coincidence, since the domain of present time reference is the domain of discussion and justification; and it is the domain of justification that would have the greatest need for verification and evaluation of how one comes to know about what one is talking about; and it would also be the domain where it would be necessary to respect social conventions of how to present what one knows. For the different contexts of narrating (mainly past time reference and past tense) and discussion and justification (mainly present time reference with present tense and present perfect), the work of Weinrich (1964 [1985]) and his predecessors is still relevant.

The development in the Baltipa dialects of the Turtuk area seems to point into the same direction. The generalised, explanatory function of *intsuk* seems to be restricted to contexts of present time reference, in that case, mainly generic facts. Historical facts are presented with the neutral past (the mere past stem) or the more emphatic past (stem & NLS & *yin*), which otherwise indicates the MSAP’s active involvement or precise memory. This again shows that the differentiation between confirmative/ ‘egophoric’ and experiential forms (*yod* vs. *snay*) and confirmative/ ‘egophoric’ and pragmatically hedged forms (*yin* vs. *yin.sug*) develops in contexts of present time reference, not in contexts of past time reference, while the development of a corresponding opposition is lacking behind in the contexts of past time and future time reference (see also Zeisler 2018b).

4.2 *The socio-pragmatic functions*

A second example from the *Mi.la.ras.paḥi rnam.thar* appears in a context similar to that discussed in section 3.3.4 (asking about the identity of an absent or distant person). Frustrated Mi.la has come to another lama, an advanced disciple of his own teacher Mar.pa. This lama is in the middle of a teaching session, so Mi.la remains apart and greets only from the distance. From his way of greeting, the lama recognises him as a disciple of Mar.pa and sends a monk to ask Mi.la who he is. The command, anticipating the direct communication between the monk and the newcomer has the plain copula *yin* for the question *who are you*. The monk, upon coming close, recognises Mi.la and thus only asks why the latter has come. He then returns to the master and tells him that it is Mi.la or rather the ‘Great Magician’ by which nickname Mi.la is known. In his answer, the monk uses the *-par-hdug* construction, de-emphasising his own perfectly certain knowledge, *as if* he had just found out:

(231) *Mi.la.ras.paḥi rnam.thar* (de Jong 1959: 71, ll. 20–21, 24–25)

«... <su *yin*> *dris-šig*» *gsuñ* |
 who be.ASS ask.IMP-DM hon.say
grva.pa-žig ṅa+ḥi sa+r byuñ-ba+s ṅo.šes-te |
 monk-LQ I+GEN place+LOC come-NLS+INSTR recognise-LB
 «*khyed ḥdi+r gañ-la byon*» *zer-ba-la* | ...
 you this+LOC what-ALL hon.arrive say-NLS-ALL
grva.pa de+s bla.ma+ḥi.druñ.du | «*a.bo thu.chen yin-pa+r-ḥdug*» |
 monk that+ERG lama+PPOS elder.brother magic.big be-NLS+LOC-ADM
 ‘[The lama said:] «... [One of you] should ask [him]: <Who are [you]?’ » One monk came over to my place and recognised [me] and said, «What is the purpose of your coming?» ... That monk [then said] in the presence of the lama: «[It] **seems to be** the elder brother, [called] the Great Magician.»’

The socio-pragmatic value of the answer could be made more explicit as follows: «Since you wanted to know, that person over there is the ‘Great Magician’, **but I do not want to claim exclusive personal knowledge in your presence.**»

We can see thus a pragmatic motivation for the use of the *-par-ḥdug* construction that is similar to the use of the Ladakhi GEM in this type of information exchange. The answer is not about the messenger’s knowledge type, but takes care of the addressee’s wish to know more. Since the addressee is of much higher status and authority, the speaker has to downgrade his epistemic authority as a sign of respect. This indicates that in the colloquial language of the 15th century, the admirative marker *ḥdug* had not only epistemic values, but also socio-pragmatic values of hedging similar to those found with the GEM in the Ladakhi dialects.

Unfortunately, apart from this example, I have not come across enough conclusive Old or Middle Tibetan examples where *ḥdug* is used with the socio-pragmatic function of downgrading in view of shared or shareable generic knowledge or for reasons of politeness. Insofar this function results from an overgeneralisation of the compound forms *inok* & siblings, I would hold that this does not constitute a process of neutralisation but rather a shift or extension towards the functionality of engagement. Hintz (2012) and Hintz & Hintz (2014/2017) seem to be the first or are among the first to have highlighted the ‘evidential’ category of mutual knowledge, which receives a special marker in some Quechua languages.

The evidential category of mutual knowledge, broadly construed, covers any assertion which the speaker assumes is held in common with the addressee(s). In other words, the speaker shares epistemic authority for the assertion with others with whom common ground has been established. Current common ground may be limited to specific information shared by interlocutors in immediate social contexts, but it may extend to facts of a general nature widely diffused through the speech community. This latter type of mutual knowledge has been referred to as “general knowledge” (Hintz & Hintz 2014/2017: 103).

Mutual or shared or perhaps rather non-exclusive knowledge plays an important role also in the Ladakhi dialects, but there is still something more to it. In his talk at the online conference *Evidentiality and Modality: At the crossroads of grammar and lexicon*, Montpellier, 10–11th June 2021, Steven Watters described the contrast between the Dzongkha copulas *î ~ ing* ([i:], [iŋ]) and *îmme*

([i:mme])⁹⁹ as indicating relative distance between interlocutors and as a means of profiling the knowledge, or perhaps better: the epistemic authority of the speaker and the potential interest or right to know of the addressee (with the usual perspective flip in questions).

The unmarked copula *ing*, usually described as indicating old knowledge (see Hyslop & Karma Tshering 2017 with further reference), would indicate that the epistemic authority is high on the speaker’s side and low on the addressee’s side, that is, the speaker assumes that s/he knows better than the addressee. The speaker’s epistemic authority concerning his/her inner states is indicated with the copula *me. imme*, on the other hand, usually described as indication of new knowledge or mirativity (see Hyslop & Karma Tshering 2017 with further reference), would then indicate that the epistemic authority is low on the speaker’s side and the right to know is high on the addressee’s side. This may imply active downgrading or downplaying of one’s epistemic authority in order to be polite or to offer a face-saving mitigation to the addressee.

I would think that in Dzongkha, similar to the situation in Ladakhi, the downplaying function is based on the lowered epistemic value of just becoming aware. Watters describes this strategy also as a knowledge gradient (in line with Heritage 2012: 7) and provides the scheme of Figure 5, which is slightly adapted according to his additional information in the presentation.

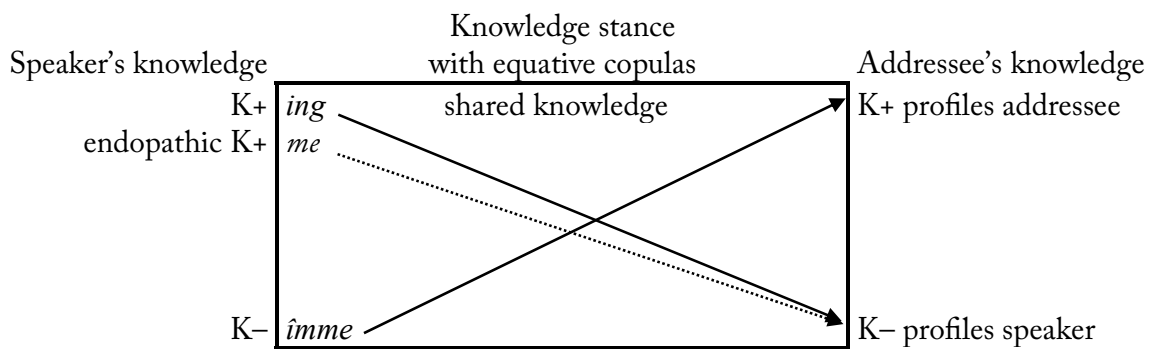

Figure 5 Profiling of epistemic authority with Dzongkha copulas, redesigned after Watters 2021

I should further think that Watter’s description of the pragmatic function corresponds quite closely to what I have been trying to describe here as the socio-pragmatic functions of *inok* & siblings and my primary division between *content at issue* and *content not at issue*. When using the GEM, it is not the case that the speaker “feels no need to justify the claim, and asks the addressee to simply take it as given”, as suggested by DeLancey (2018: 583) for the so-called ‘factual’ markers *red* and *yod.red* in Standard Spoken Tibetan. Rather, the speaker turns the focus away from his/her epistemic authority, leaving it open by which means his/her knowledge was acquired (or according to DeLancey 2018: 588, by “simply disregard[ing] the question of evidence”), but also remaining open for further elaborations. S/he may even give the impression that his/her knowledge base is shaky. The focus is then set on the presumed knowledge of the addressee or, as far as the addressee is expected not to know, the speaker focuses on the potential or explicitly indicated interest of the addressee to know more.

⁹⁹ Hyslop & Karma Tshering (2017) Romanise the two forms as *'ing* ([iŋ]) and *'immä* ([i:mme]), suggesting a high tone realisation.

I should thus like to elaborate Watter's model as follows: the gradient would be about the speaker's epistemic authority, which is highest when talking about oneself and one's personal sphere and lowest for mere assumptions. This gradient is only in the lower part also an epistemic gradient of knowledge or lesser certainty; otherwise, it is a pragmatic gradient of epistemic rights.

Figure 6 shows the gradients for the copula. The system is even more complex with respect to the existential linking verbs, because contexts of sense perception have their own markers, Figure 7. Please note, both figures can only be approximations to the multidimensional network of meanings.

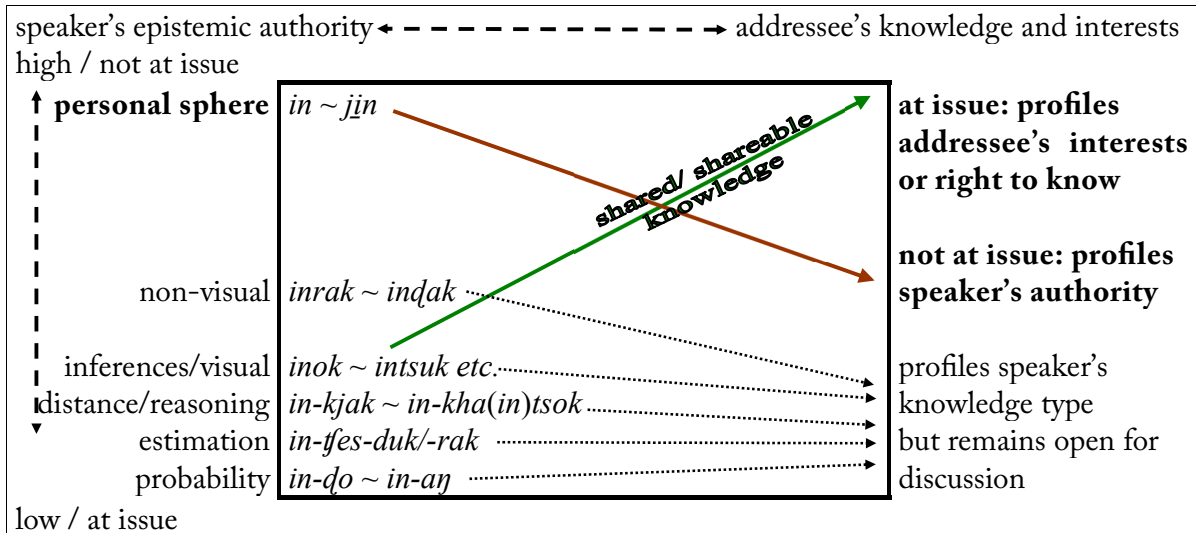

Figure 6 Profiling of communicative interests with Ladakhi copulas

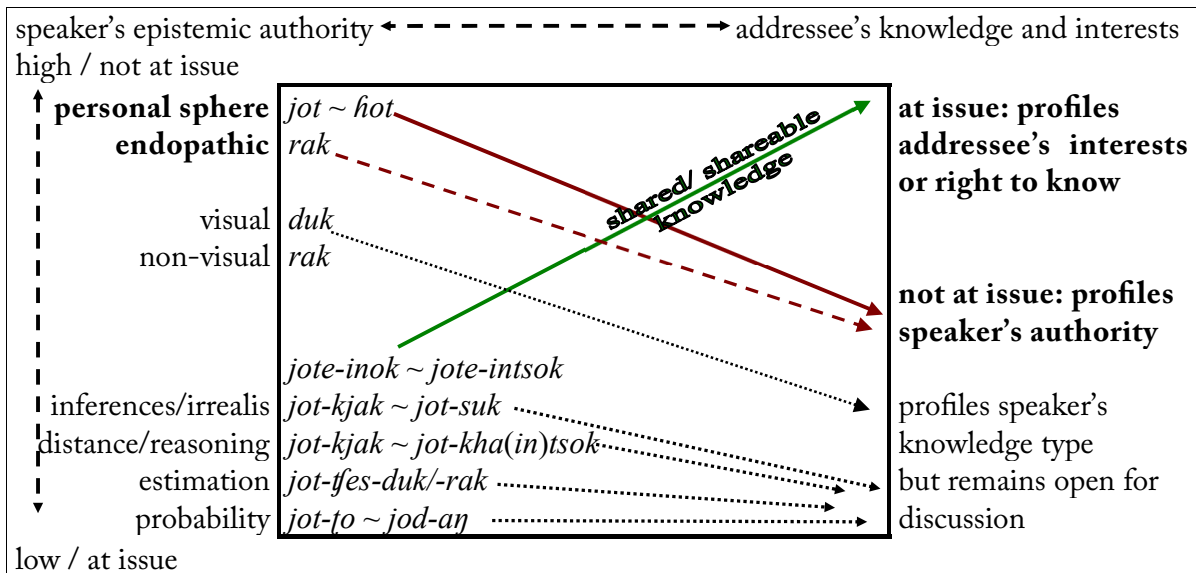

Figure 7 Profiling of communicative interests with Ladakhi existential linking verbs

Knowledge based on sense perceptions belongs to the field of the speaker's personal and potentially exclusive knowledge, but his/her authority over merely perceived situations outside his/her personal sphere or territory of information is lower than his/her lived experience within his/her

own personal sphere or territory of information. Inferences and reasoning also belong to the field of his/her personal and potentially exclusive knowledge, but some of the forms used for inference and reasoning, mainly *inok* & siblings but also the Kenhat future inferential, can be used to indicate non-exclusive, that is, shared and shareable knowledge. The described kind of epistemic fine-tuning concerns the whole ‘evidential’ system. The choice between the Set 1 markers *yin* and *yod*, on the one hand, and all other markers indicates not only different types of knowledge, but also whether or not one is responsible and whether or not one feels closely related, or identifies, with the reported situation *and* the addressee. When telling the addressee that a certain item does not belong to him/her, it doesn’t matter that one has the best possible knowledge because of being the owner of the item. One is, nevertheless, not responsible for the fact that the addressee does not possess it. When being closely related or when identifying with the situation, one retains a higher degree of epistemic authority, whereas when taking a distanced stance, one downgrades one’s epistemic authority. Similarly, one may downgrade one’s epistemic authority when one feels more closely related with the addressee than with the reported situation. The main communicative problem is to balance one’s (subjective) relationship of closeness or distance towards the situations described against one’s (subjective) relationship towards the addressee and against the addressee’s potential right to know and interest and against the latter’s potential relationship toward items or persons to be mentioned. Speakers of different dialects, as well as individual speakers of a given dialect, may differ in how exactly they position themselves in the communicative situation and which markers they chose. But when they chose the GEM or combinations with the GEM in order to downplay their epistemic authority, it does not matter whether the GEM has the form *intsok* or *inok* or even *inman* or *inne*, for that matter.

Downplaying one’s epistemic authority may sometimes also have other reasons than to profile the addressee’s right to know, namely indicating one’s emotional distance to a situation. This has been also described for the ‘neutral’ copula *be?* in Denjongke:

This implies that *i:* is more concerned with the act of identifying itself, as if performing a type of speech act of identifying, whereas *be?* takes some distance from identifying and so suggests focusing on the implications of this identification (e.g. activities of a doctor) (Yliniemi 2019: 271).

[T]he auxiliary use of *be?* implies that the speaker distances [him- or her]self from the claim of familiarity with the situation (Yliniemi 2019: 363).

By using an evidentially neutral form, the speakers distance themselves from the situation depicted by the proposition (Yliniemi 2019: 366).

[T]he speaker may create distance to [his/her own] action which happened a long time ago by using the neutral copula (Yliniemi 2019: 375).

Michael (2020: 99), drawing upon various examples of ‘discursive strategies’ for avoiding epistemic and social responsibilities in different languages, observes that there is a striking asymmetry between strategies of downplaying epistemic authority in order to mitigate blameworthiness and strategies employed to construct praiseworthiness. Self-mitigation seems to be quite common, but self-praising strategies would be rarely used. According to him, “[t]his asymmetry may stem from the fact that evidentiality easily serves as a means for speakers to distance themselves from events, which readily lends itself as a strategy for reducing responsibility, but not for increasing it” (ibid). The same may be said about epistemic markers in general and about admirative or non-confirmative markers in particular.

5 Conclusion

I should like to point once more to the important fact that no other marker or combination, except complex constructions with *inok* & siblings, shows both an epistemic function and the *multitude* of pragmatic functions described above. It follows, therefore, that whatever form *inok* & siblings take, for all practical purposes, they take the same functional slot within the ‘evidential’ paradigm as opposed a) to the ‘evidential’ markers for ego-centred and perceptive knowledge and b) to the other, more epistemic markers.

This becomes particularly evident when one looks at the two dialects that show a mixed pattern: Lingshetpa (Southern Shamma) and Teyapa (Eastern Shamma). Both dialects use the Shamskat inferential-*cum*-distance marker *-suk/-sok* in all combinations except in the combination with the copula, where the Central Ladakhi combination *inok* is used. The Eastern Shamma dialect of Teya also shares the complex distance marker *-kha((n)i)ntsok* with the Western Shamma dialects. The Southern Shamma dialect of Lingshet, on the other hand, shows a distance marker of the Kenhat type: Lingshetpa *-ka(no)k*, Zanskarpa *-ka(no)ʔ*, Upper Indus and Changthang area *-ka(na)k* and Leh area *-kjak*, see Table 10, which partially repeats Table 3 of section 2.4.

	GEM	mirative	inference	distance	past/ narrative
WShamma	<i>intsok</i>		<i>-sok</i>		<i>-kha((n)i)ntsok</i>
EShamma	<i>inok</i>		<i>-sok</i>		<i>-kha((n)i)ntsok</i>
SShamma	<i>inok</i>		<i>-sok</i>	<i>-ka(no)k</i>	(-Bintsok)
Central	<i>inok</i>	<i>-suk/-sok</i>	<i>-tok</i>	<i>-kjak</i>	-Bintsok
Up.Indus	<i>jɪnak</i>	<i>-suk</i>	-Dok	-Ga(na)k	-Ga(i)ntsok

Table 10 Paradigmatic epistemic contrasts of *inok* & siblings across the dialects

This mixing of Shamskat and Kenhat forms clearly indicates the functional relationship between all the forms summarised here as GEM or as *inok* & siblings. One cannot deny that Western Shamma *intsok* takes exactly the same position in the ‘evidential’ (and epistemic) paradigm as Eastern Shamma *inok*. By contrast, the slots in the paradigm of the Lingshetpa dialect rather seem to correspond to those of the Kenhat dialects, except for the fact that the inferential-*cum*-distance marker *-sok/-suk* is used in place of the past inferential marker *-tok/-tuk*. In that case, *inok* certainly takes the same position in the paradigm and can be expected to have the same functionality as *inok* and its mere phonetical variants of the Kenhat dialects.

Given this distribution across the dialects, it does not seem to be expedient to assume – without further evidence than the variation in the epistemic slots – that Eastern Shamma *inok* had not roughly the same functionality as Southern Shamma and Central Ladakhi *inok*. If that conclusion can be accepted, then it is also not expedient to assume – again without further evidence than the difference in form – that western Shamma *intsok* had not the same functionality as Eastern Shamma *inok*. All evidence points into the opposite direction, namely that Western Shamma *intsok* has the same functions as Eastern and Southern Shamma *inok*, which again has the same functions as Central Ladakhi *inok* and Upper Indus *jɪnak* etc..

The many parallel examples indicate that throughout all Ladakhi dialects of the core area, *inok* & sibling have roughly the same epistemic and pragmatic functions. Neither are the Kenhat forms *inok*, *jindak*, etc. restricted to generic contexts, nor is the Shamskat form *intsok* ~ *intsuk* restricted to inferences. Both types of markers have approximatively the same functional distribution. A greater functional divergence shows up only in some irrealis contexts and with emotionally motivated usages. One important function shared by all dialects of the core area is the use of *inok* & siblings in explanations and for shared knowledge, particularly generic facts. In the periphery, that is, in the Baltipa, Purikpa, and Pangipa dialects, the corresponding forms are clearly much less developed, showing less of these generalised or ‘factual’ usages, and these mostly only when the combination functions as copula, not when functioning as an auxiliary. Nevertheless, these usages cannot be ignored.

Table 11 below shows the distribution of the GEM or related forms across the dialect regions for the various contexts described above. Light yellow shading is used for the core area, light green shading for the peripheral areas. A hatching pattern indicates limited usages. Grey shading is used for semantically peripheral contexts. An asterisk indicates contexts established in 2019 or later, for which only few informants could be asked.

One will see that in the first two groups of contexts, the GEM is widely shared by the dialects surveyed. Particularly within the core Ladakhi group, there is only minor variation. This distribution certainly allows to treat *inok* & siblings as the same marker with the same term. As far as the available data show, the corresponding sibling is also found in the more peripheral dialects in more than half of the contexts of the first two groups. Some of these contexts still imply the original epistemic function of *inok* & siblings (3 out of 10 in the first context group, 1 of 3 in the second context group). Nevertheless, *inok* & siblings are also attested in the periphery with a generalised pragmatic function in about half of both contexts (4, if not even 5 out of 10 in the first context group, 2 of 3 in the second context group). In my opinion, this allows to treat the particular siblings of the peripheral area on the same level as the GEM of the core area.

The third group of contexts contains emotionally motivated usages, such as feeling shame, sarcastic usages, or also expressions of pride and defiance. In these contexts, the GEM is found only in a few dialects, mainly of the central region. Arguably, these are contexts that have only little to do with the epistemic and pragmatic functions that are typical for the GEM. In particular, the limited usage of the GEM to indicate one’s pride or defiance cannot be taken as evidence that the GEM generally signals the MSAP’s heightened authority. The comparatively unexpected use of the GEM for oneself in contrast to the ‘egophoric’ marker *yin*, signals that something is not the way it is normally expected to be, and this may take both negative and positive connotations of shame or pride.

Similarly, the irrealis contexts of the fourth group could be said to be unrelated. One could further argue that in these contexts and in the context of counterexpectation, we do not deal with the Western Shamma compound form *intsok* but solely with the Western Shamma inferential-*cum*-distance marker *-suk/-sok*. This would be corroborated by the fact that in these contexts, *-suk/-sok* appears as a special mirative distance marker for various other dialects. In Table 11, I have thus listed only the inferential-*cum*-distance marker for the Western Shamma dialects. On the other hand, it is interesting to see that Lingshetpa *inok*, Çarapa *inak*, and Pangipa *jinne* share the mirative function of the Western Shamma compound form *intsok*. This indicates that the mirative and irrealis function of *intsok* cannot be separated from all the other epistemic and pragmatic functions of the compound form.

contexts	peripheral dialect area			core dialect area		
	form of the GEM <i>inmaj/-tsuk jinne</i> Turtukpa Pangipa	<i>intsuk</i> Purikpa	<i>intsuk</i> WSham	<i>inok</i> SSham	<i>inok</i> etc. Kenhat	
1. identifications, mainly copula usage						
inference, immediate realisation	+	± ¹⁰⁰	+	+	±	
identification via vision	+	+	+	+	+	
recognising from the distance	+	+	+	+	+	
(subjective) unrelatedness	(+)	+	+(EPur.)	+	+	
requirement of politeness	–	n.d.	–	+	+	
playful talk with children	+	+	+	+	+	
absence; persons at door/phone * <i>mine, not yours</i> *	? ¹⁰¹	(+) ¹⁰²	+	+	+(ESham) ±	
explanatory mood	+ ¹⁰⁴	+	%	+	±(ESh.) ¹⁰³ +	
shared observations	n.d.	n.d.	+(EPur.)	+	n.d. +	
2. complex constructions						
assumptions (GRD+GEM)	n.d.	+	+	+	+	
planning, suggesting (GRD+GEM) *	n.d.	+	% (EPur.)	+	+	
generic perfect (LB+GEM) * or DPG	n.d.	–	% ¹⁰⁵	+	(+) ¹⁰⁶ ; DPG ±/ DPG	
3. emotionally motivated usages						
feeling shy or ashamed	–	–	–	–	+(ESham) ±	
sarcastic usage for oneself	n.d.	n.d.	–	+	+	
other emotional emphasis	n.d.	n.d.	% (SPur.)	n.d.	n.d. +	
4. mirative function of <i>sug</i> vs. GEM						
sudden realisation, surprise	<i>sug</i>	GEM	–	<i>sug</i>	GEM	<i>sug</i> / GEM
shifted stance/ background	<i>sug</i>	(GEM) ¹⁰⁷	<i>sug</i> (SPur.)	<i>sug</i>	–	<i>sug</i>
irrealis, play roles	–	GEM	–	<i>sug</i>	GEM	<i>sug</i>
irrealis, imagined situations	–	GEM	–	<i>sug</i>	GEM	±GEM

Table 11 Contexts for the use of the GEM across dialect areas

¹⁰⁰ Both the experiential marker *naŋ* and a perfect construction with the GEM have been observed.

¹⁰¹ In the context of absence, *intsuk* seems to be preferred, but I have noted down also plain *in* and, in the context of a phone call, *in* and *inmaj*. The exact functional distribution could not yet be established.

¹⁰² When pointing to persons on a photograph, the informant would use the plain copula for persons present, but the GEM for absent persons.

¹⁰³ Rejected by the Lingshetpa speaker from Southern Sham, but used by the Teyapa speaker from Eastern Sham.

¹⁰⁴ Mainly *intsuk*, rarely *inmaj*.

¹⁰⁵ Only for existential constructions.

¹⁰⁶ Apart from the use with existentials, the perfect is used for shared knowledge concerning activities of speaker and addressee. The generic context could not yet be checked.

I would assume, however, that the contexts of group 3 and 4 are not relevant for the definition of the functionality of *inok* & siblings. If in any dialect, *inok* or one of its siblings is used in these contexts, this is just an extra benefit, so to speak, of the downgrading strategy. The important contexts are the epistemic usages as inferentials and the pragmatic usages, particularly the use to indicate one's non-relatedness and the use for shared or shareable knowledge and generic facts. It is these latter usages where *inok* & siblings can be directly compared to the so-called 'factual' copula *red* in Central and Eastern Tibetan.

As already indicated, I am not quite sure that I understand what other authors mean when they use the terms 'factual' or 'assertive' or in some cases also 'statemental' or 'neutral' for describing the seemingly 'non-evidential' usage of Central and East Tibetan *red* and *yod.red/yod.na.red* (and their regional counterparts). I would expect that a non-evidential 'factual', 'statemental', or 'neutral' marker corresponds to what the Standard European languages represent with the neutral, non-modal verb forms. These are, of course, also used for the speaker's most personal knowledge. As far as I can judge, this is also the general cross-linguistic position, see, e.g., Tantucci (2016). For a very elaborative discussion of 'factual' or, in his terminology, 'general knowledge' see Kittilä (2019). He describes two types of 'general knowledge', namely generic knowledge, such as knowledge about scientifically established facts, and settled knowledge about facts and situations established through personal experience (p. 1283). According to him, egophoric markers or "ego-evidentials rather typically code general knowledge if they exist in a language" (p. 1293).

The Ladakhi GEM would certainly not be correctly translated with a neutral English verb form, even though the modal forms are usually too strong, especially with their epistemic hedging connotations. The Standard European languages lack the intermediate tones in their grammar. Some of these intermediate nuances would be captured by modal particles like German *wohl, ja, halt, eben, or doch*. Since the Ladakhi GEM would translate many usages of Central and East Tibetan *red*, I wonder thus how 'neutral' or 'factual' the latter auxiliary actually is, and whether *red* and its various counterparts could or should be translated with a factual, i.e., non-modal, verb form of English or without any of the modal particles in German.

When I presented these data and questions at the Himalayan Languages Symposium in Sydney 2019, Scott DeLancey reacted to the above remark, saying that, of course, the 'factual' represents generic knowledge. If this were true, then the GEM cannot be a 'factual' marker, if 'factual' is seen as a grammatical category. Generic situations or 'factual' as a semantic notion are expressed by various grammatical constructions in Ladakhi, so that one can at best speak of various 'factual' strategies, and the GEM clearly also has other functions. The GEM and auxiliary constructions with the GEM would at best make up a subset of such 'factual' strategies.

Pragmatic hedging, on the other hand, seems to be the one thing *inok* & siblings can express better than any other marker. They are the preferred tool to abstract from one's own knowledge, even from one's own person and personality. One can see this in the speech behaviour of the students, with whom I usually work. While an elderly member of a family of comparatively high status described facts plainly as they were with Set 1 markers, because, as he said, he knew them or was interested in them, the students would typically chose an impersonal hedged style, downplaying, if not negating personal authority. By using an originally epistemic marker, such as the GEM or the DPG, they would avoid representing themselves as authorities. While the confident elderly

¹⁰⁷ In story telling, *jinne* appears also as narrative distance marker after verbs. Its function in this particular context is thus ambiguous.

Ladakhi man presented facts as unquestionable facts with the weight of full personal authority, the younger Ladakhi speakers tend to present facts as mere possibilities. One may well call this a special ‘factual’ *strategy*.

In the long run, the socio-pragmatic restrictions, which hinder many Ladakhi speakers to put themselves or their knowledge into the focus, may lead to an over-exploitation of the mitigating strategies, so that in the end, the only way to talk about facts is to present them in an originally non-factual way, with the original epistemic notions completely bleaching out. One may then call the original epistemic markers ‘factual’ markers, but one should at least be aware of their origins. I should further expect that as soon as such ‘factual’ markers have lost any connotation of epistemic hedging, new markers or expressions of epistemic hedging will come into use, and they will then be exploited again for downgrading or mitigating one’s epistemic authority and/ or commitment.

The available descriptions of Modern Tibetic languages usually do not go far beyond the prototypical usages of the ‘evidential’ and ‘egophoric’ markers. Nevertheless, one can come across isolated usages that correspond to the pragmatic functions of the GEM described above. There are a few examples for an irrealis function of *red*, see examples (77) in section 3.2.2, and (85) to (88) in section 3.2.3. While so far never described as such, individual examples could further certainly be interpreted as profiling the addressee’s knowledge state or interest or the addressee’s right to know or as serving other socio-pragmatic functions, like the interaction with small children, see example (125). The available descriptions also indicate that *red* is used not only for generic contexts. As has been shown for Standard Spoken Tibetan, *red* may be used to indicate that the MSAP acted without, or with only a low degree of, intentionality, while especially the compound form *yod.red* may represent inferences (cf. Garrett 2001: 40f. ex. 19 and 42, ex. 20).

My impression is that the term ‘factual’ is used in many descriptions in a rather indiscretionary manner or as a fuzzy portmanteau term, which covers up various different functions. Therefore, I should like to suggest that it is high time to define the term ‘factual’ more precisely or perhaps even replace it with a better term, and to develop a more fine-grained analysis of the various functions of *red*, *yod.red*, and their various counterparts.

Accordingly, one of the reasons why I present here the various functions of the Ladakhi GEM, or *inok & siblings*, is to point at the, in my view, problematic status of the term ‘factual’. Another, perhaps even more important reason is to enable speakers and researchers of other Modern Tibetan varieties and also other languages showing similar systems to compare the contexts in which *inok & siblings* appear with the actual usages of *red* and *yod.red* (or their equivalents) and to acquire a better understanding of their position in the evidential, epistemic, and attitudinal system(s) of these varieties. Even though I could find a few rough parallels, *red* and *yod.red* (or any of their regional counterparts) will certainly not translate all usages of *inok & siblings*. But I expect similar pragmatic reasons behind their usage, notably reasons that have to do with the assumed knowledge state of the addressee or the whole speech community. That personal stance and social interaction may, in fact, play a crucial role, has been shown recently by Camille Simon (2019) for Amdo Tibetan and by Erika Sandman (2019) for Wutun, a Sinitic language under the influence of Amdo Tibetan.

The above examples, as well as the examples or descriptions from other Tibetic languages show the multi-dimensionality of the assumed ‘factual’ or ‘evidential-neutral’ category. The various dimensions comprise at least spatial and mental distance as well as socio-pragmatic parameters of playful or more honorific talk. To describe the corresponding markers: *red*, *sbad*, or *inok & siblings*, and their existential counterparts merely as ‘neutral’, deprives them of their multi-dimensionality and markedness.

ACKNOWLEDGEMENTS

I am incredibly indebted to all informants for their patience and willingness to answer my questions about nuances they would usually not give the slightest thought to. I am similarly indebted to all interlocutors, narrators, and informants for presenting me spontaneously with usages that I could not have imagined to exist, and hence could never have asked anybody about them. The following persons have contributed to this study (those with an asterisk after their name are without examples):

- Abdul Hamid* and Faizulla from Turtuk (Eastern Baltipa enclave, Ldumra a.k.a. Nubra);
- Abbas Ali and Herun Neza from Tyaksi and Thang (Eastern Baltipa enclave, Ldumra);
- Tashi Tshering* from Henache and Tshering Youron* from Aranu (northern Ldumra);
- Stanzin Yangskit from Sumur (central Ldumra);
- Mohmad Hussain from Sankoo (southern Purik);
- Tshering Padma from Wakka and *ane* Lobzang Paldzes from Mulbek (eastern Purik);
- Sarfraz Ahmet from Ciktan (eastern Purik);
- Phuntsok Dolma from Tagmacik (western Sham);
- Tshewang Tharcin, Tshering Angcuk, and Tshering Tshomo from Domkhar (western Sham);
- late *meme* Tundup Tshering, interlocutor and narrator from Khalatse (western Sham);
- Tshering Dolkar from Teya (eastern Sham);
- Phuntsok Dolma* from Saspol(a) (eastern Sham);
- Tundup Namgyal from Lingshet (southern Sham);
- late *azhang* Namgyal, my host from the Shalak family in Leh (central Ladakh);
- late *abi* Padma Angmo, interlocutor from the Nochung family in Leh (central Ladakh);
- Rinchen Dolma, second generation in Leh (central Ladakh);
- Phuntsok Paljor, narrator from Stok (central Ladakh);
- Kunzang Dolma from Rumbak (central Ladakh);
- Kundzes Dolma from Rale (Lalok, northern Changthang);
- Tanzin Lamo* and Dechen Dolkar* from Trangtse and Tharuk (Lalok, northern Changthang);
- Tshering Kundzes from Shachukul (Lalok, northern Changthang);
- Chamba Tsetan from Kārgyam (Lalok, northern Changthang);
- Angcuk Dorje* from Merak (Lalok, northern Changthang);
- Tundup Dorje from Chushul (Lalok, northern Changthang);
- Thugje Dolma from Çara (a.k.a. Shara, Upper-Indus);
- Thinle Nurbu from Lik̄tse (Upper-Indus);
- Tshewang Chikit from Kyungyam (Upper-Indus);
- Jigmet Angmo from Gyaik (Upper-Indus);
- Sonam Dorzhe from Gyere (Upper-Indus);
- Mengyur Tshomo & Jigmet Yangdol from Gya-Miru (Upper-Indus side valley);
- Rigzin Samdrup from Mūt, a.k.a. Moot (south-eastern Changthang, border to Tibet);
- Jigmet Tandar* from Kuyul (south-eastern Changthang, border to Tibet);
- Tsering Angtak from Kharnak (southern Changthang, border to Himachal Pradesh);
- Sonam Tundup from Faḍum a.k.a. Padum (central Zaskar);
- Tenzin Yangdu* from Paldar (Zaskarpa enclave, Kishtwar);
- Tenzen Dolkar from Pangi (mixed dialect enclave, Himachal Pradesh).

Rainer Kimmig, University of Tübingen, kindly provided me with the citation of Mahima-bhaṭṭa. Much of this work has been financed by the anonymous taxpayer via the German Research foundation DFG (various projects, particularly the current project 2016-2019/ 2022-2024). I should further like to thank all three reviewers, especially Rev1 and Rev2 for taking up the task a second time. Apologies for not always following their suggestions.

ABBREVIATIONS AND CONVENTIONS

Round brackets after translations are directly based on the informants' explanations.

Square brackets indicate my interpretation, often based on different examples.

x=y	'x functions as y' (not a clitic marker!)	hon	honorific
x_y	clitic marking (citing other authors)	IMP	imperative
.x	implied form in example text or lexeme	IMPF	imperfect
	boundary of glossed compounds	incl	inclusive plural form
x-y	segmentable morpheme boundary	INF	inferential
x+y	non-segmentable morpheme boundary	INF/DST	inferential- <i>cum</i> -distance marker
x_ _y	assimilation effects across the word	INSTR	instrumental
	boundary	IZF	<i>izāfat</i>
*	(as prefix): not acceptable/ reconstructed	LB	<i>lhag.bcas</i> converb (- <i>ste</i>)
&	(as prefix): preferred form/ construction	LOC	locative
%	dispreferred, only in special contexts	LQ	limiting quantifier: <i>a, some</i>
ABL	ablative	LV	linking verb
ABL/LOC	formal ablative with locative function	MDST	'mirative' distance marker
ADM	admirative (<i>hdug</i>)	MSAP	main speech act participant
AES	aesthete (experiencer subject)	NG	negation
ALL	allative	NLS	nominaliser
ASS	assertive (<i>yin</i> or <i>yod</i>)	NLSA	nominaliser with additional ablative
Aux	auxiliary	NVIS	non-visual marker (<i>rag</i>)
CD	conditional	PA	(neutral, unspecified) past
coll	collective plural form	PERF	perfect
CNJ	conjunction	PERF.NRS	perfect of negative result (indicating disappearance or total destruction of transformed item)
CNT	continuative		
CNTR	contrastive		
COM	comitative	PL	plural
CP	copula <i>yin</i>	PPOS	postposition (locational)
DF	definiteness marker	PRB	probability marker
DM	directive marker (for commands and prohibitions)	PRHB	prohibitive
		PROSP	prospective
DPG	depersonalised generic knowledge marker	PRS(/FUT)	present (and/or future)
		QM	sentence question marker
DST	mental distance marker	QOM	quote marker
emp	emphatic marker	RM	remoteness marker (turns present tense into imperfect and marks past tense as belonging to, or being well remembered by, the MSAP)
ERG	ergative		
EX	existential linking verb <i>yod</i>		
EXP	experiential marker (<i>hdug, snay</i>)		
excl	exclusive plural form	SEM	specialised evaluative marker
fem	feminine derivation	SF	sentence final
FM	focus marker	TOP	topic marker
FUT	(neutral) future	V	verb
GEN	genitive	VIS	visual marker (<i>hdug, snay</i>)
GEM	generalised evaluative marker	(X)	existential linking verb <i>yod</i> , used as attributive copula
GRD	gerundive		
HAB	assertive habitual		

REFERENCES

- Agha, Asif. 1993. *Structural form and utterance context in Lhasa Tibetan. Grammar and indexicality in a non-configurational language*. New York etc.: Peter Lang [Monographs in linguistics and the philosophy of language, 2].
- Aikhenvald, Alexandra Yurievna. 2003. "Evidentiality in typological perspective". In: Aikhenvald, Alexandra Yurievna; and Dixon, Robert Malcom Ward (eds.), *Studies in evidentiality*, 1–31. Amsterdam, Philadelphia: Benjamins [Typological Studies in Language, 54].
- Aikhenvald, Alexandra Yurievna. 2004. *Evidentiality*. Oxford: Oxford University Press.
- Aikhenvald, Alexandra Yurievna. 2014. "The grammar of knowledge: a cross-linguistic view of evidentials and the expression of information source". In: Aikhenvald, Alexandra Yurievna, and Dixon, Robert Malcom Ward (eds.), *The grammar of knowledge. A cross-linguistic typology*, 1–51. Oxford: Oxford University Press.
- Aikhenvald, Alexandra Yurievna. 2015. "Evidentials: their links with other grammatical categories". *Linguistic Typology* 19.2: 239–277.
- Aikhenvald, Alexandra Yurievna. 2018. "Evidentiality, the framework". In: Aikhenvald, Alexandra Yurievna (ed.): *The Oxford handbook of evidentiality*, 1–45. Oxford: Oxford University Press [Oxford Handbooks in Linguistics].
- Anderson, Lloyd B. 1986. "Evidentials, paths of change, and mental maps: typologically regular asymmetries". In: Chafe, Wallace; and Nichols, Johanna (eds.), *Evidentiality: the linguistic coding of epistemology*, 273–312. Norwood, NJ: Ablex [Advances in Discourse Processes, 20].
- Beal, Samuel. 1869. *Travels of Fab-Hian and Sung-Yun, Buddhist pilgrims, from China to India (400 A.D. and 518 A.D.)*. London: Trübner.
- Bendix, Edward H. 1993. "The grammaticalization of responsibility and evidence: interactional potential of evidential categories in Newari". In: Hill, Jane H.; and Irvine, Judith T. (eds.), *Responsibility and evidence in oral discourse*, 226–247. Cambridge: Cambridge University Press.
- Bergqvist, Henrik; and Kittilä, Seppo. 2017. "Person and knowledge: introduction". *Open Linguistics* 3: 18–30. <https://doi.org/10.1515/opli-2017-0002>. Accessed Mar. 21, 2017.
- Bergqvist, Henrik; and Kittilä, Seppo (eds.). 2020. *Evidentiality, egophoricity, and engagement*. Berlin: Language Science Press [Studies in Diversity Linguistics, 30]. <https://doi.org/10.5281/zenodo.3968344>. Accessed Sep. 14, 2020.
- Bickel, Balthasar. 2008. "Verb agreement and epistemic marking: a typological journey from the Himalayas to the Caucasus". In: Huber, Brigitte; Volkart, Marianne; and Widmer, Paul (eds.), *Chomolangma, Demawend und Kasbek. Festschrift für Roland Bielmeier zu seinem 65. Geburtstag*. Band I: Chomolangma (Chomolangma, Demawend and Kasbek. Festschrift for Roland Bielmeier on his 65th birthday. Vol. 1: Chomolangma), 1–14. Halle: International Institute for Tibetan and Buddhist Studies.
- Bielmeier, Roland. 1985. *Das Märchen vom Prinzen Čobzañ. Eine tibetische Erzählung aus Baltistan. Text, Übersetzung, Grammatik und westtibetisch vergleichendes Glossar* (The tale of prince Čobzañ. A Tibetan tale from Baltistan. Text, translation, grammar, and comparative West-Tibetan glossary). St. Augustin: VGH Wissenschaftsverlag [Beiträge zur Tibetischen Erzählforschung, 6].
- Bielmeier, Roland. 1988. "On tone in Tibetan". In: Uebach, Helga; and Jampa L. Panglung (eds.), *Tibetan Studies. Proceedings of the 4th Seminar of the International Association for Tibetan Studies*.

- Schloß Hohenkammer - Munich 1985*. Vol. II, 43–54. München: Kommission für Zentralasiatische Studien, Bayerische Akademie der Wissenschaften.
- Bielmeier, Roland. 2000. “Syntactic, semantic, and pragmatic-epistemic functions of auxiliaries in Western Tibetan”. In: Bickel, Balthasar (ed.), *Person and evidence in Himalayan languages*, Part I. Special issue of *Linguistics of the Tibeto-Burman Area* 23.2: 79–125.
- Bielmeier, Roland et al. 2018. *Comparative Dictionary of Tibetan Dialects (CDTD)*. Volume 2: Verbs. Berlin/ Boston: De Gruyter Mouton [Trends in Linguistics, Documentation, 34].
- Brugman, Claudia M.; and Monica Macaulay. 2015. “Characterizing evidentiality”. *Linguistic Typology* 19.2: 201–237. <https://doi.org/10.1515/lingty-2015-0007>. Accessed Sep. 21, 2021.
- Bruil, Martine. 2015. “When evidentials are not evidentials: the case of the Equadorian Siona reportative”. *Linguistic Typology* 19.3: 385–423. <https://doi.org/10.1515/lingty-2015-0012>. Accessed Oct. 10, 2016.
- Creissels, Dennis. 2008. “Remarks on the so-called “conjunct/disjunct” systems”. Paper given for Syntax of the world’s languages III, Berlin, 25–28 September 2008. <http://www.deniscreissels.fr/public/Creissels-conj.disj.pdf>. Accessed May 21, 2015.
- de Haan, Ferdinand. 2005. “Encoding speaker perspective: evidentials”. In: Frajzyngier, Zygmunt; Hodges, Adam; and Rood, David S. (eds.), *Linguistic diversity and language theories*, 379–397. Amsterdam, Philadelphia: Benjamins [Studies in Language Companion Series, 72].
- de Haan, Ferdinand. 2012a. “Evidentiality and mirativity”. In: Binnick, Robert I. (ed.), *The Oxford handbook of tense and aspect*, 1020–1046. Oxford, New York: Oxford University Press.
- de Haan, Ferdinand. 2012b. “Evidentiality and mirativity”. In: Binnick, Robert I. (ed.), *The Oxford handbook of tense and aspect*, 1–28 Oxford: Oxford Handbooks Online. <https://doi.org/10.1093/oxfordhb/9780195381979.013.0036>. Accessed, Jul. 22, 2014.
- DeLancey, Scott. 1986. “Evidentiality and volitionality in Tibetan”. In: Chafe, Wallace; and Nichols, Johanna (eds.), *Evidentiality: the linguistic coding of epistemology*, 203–213. Norwood, NJ: Ablex. [Advances in Discourse Processes, 20].
- DeLancey, Scott. 2012. “Still mirative after all these years”. *Linguistic Typology* 16: 529–564. Originally accessed from <https://doi.org/10.1515/lingty-2012-0020>, May 2, 2013. [Now available under <https://doi.org/10.1515/lity-2012-0020>].
- DeLancey, Scott. 2018. “Evidentiality in Tibetic”. In: Aikhenvald, Alexandra Yurievna (ed.), *The Oxford handbook of evidentiality*, 580–594. Oxford: Oxford University Press [Oxford Handbooks in Linguistics].
- Denwood, Philip. 1999. *Tibetan*. Amsterdam, Philadelphia, PA: Benjamins [London Oriental and African Language Library, 3].
- Ebihara, Shiho. 2017. “Evidentiality of the Tibetan Verb *snang*”. In: Gawne, Lauren; and Hill, Nathan W. (eds.), *Evidential systems of Tibetan languages*, 41–59. Berlin; Boston: De Gruyter Mouton [Trends in Linguistics, Studies and Monographs, 302]. (<https://doi.org/10.1515/9783110473742-002>).
- Evans, Nicholas; Bergqvist, Henrik; and San Roque, Lila. 2018a. “The grammar of engagement I: framework and initial exemplification”. *Language and Cognition* 10: 110–140. <https://doi.org/10.1017/langcog.2017.21>. Accessed Feb. 19, 2019.
- Evans, Nicholas; Bergqvist, Henrik; and San Roque, Lila. 2018b. “The grammar of engagement II: typology and diachrony”. *Language and Cognition* 10: 141–170. <https://doi.org/10.1017/langcog.2017.22>. Accessed Feb. 19, 2019.

- Floyd, Rick. 1999. *The structure of evidential categories in Wanka Quechua*. Arlington, Dallas: The Summer Institute of Linguistics and The University of Texas at Arlington [Summer Institute of Linguistics and The University of Texas at Arlington Publications in Linguistics, 131].
- Floyd, Simeon; Norcliffe, Elisabeth; and San Roque, Lila. 2018. *Egophoricity*. Amsterdam/ Philadelphia: Benjamins [Typological Studies in Language, 118]. <https://doi.org/10.1075/tsl.118>. Accessed Dec. 30, 2020.
- Francke, August Herrmann. 1905–41. *Gšam.yul.na bšad.pa.ħi ke.sar.gyi sgruñs. A Lower Ladakhi version of the Kesar saga*. Calcutta 1905–1909 (Fasc. 1–4), 1941 (Fasc. 5): Royal Asiatic Society of Bengal [Bibliotheca Indica, work, 168]. [Reprint 1981: *The Epic of Gesar*. Kunzang Tobgyel; and Mani Dorje, Vol. 29. Thimphu, Bhutan: Druk Sherig Press].
- Friedman, Victor. 1981. “Admirativity and confirmativity”. *Zeitschrift für Balkanologie* 17.1: 12–28.
- Friedman, Victor. 2000. “Confirmative/nonconfirmative in Balkan Slavic, Balkan Romance, and Albanian with additional observations on Turkish, Romani, Georgian, and Lak”. In: Johanson, Lars; and Utas, B. (eds.), *Evidentials Turkic, Iranian and neighbouring languages*, 329–366. Berlin: Mouton de Gruyter.
- Garrett, Edward John. 2001. *Evidentiality and assertion in Tibetan*. PhD dissertation, University of California. <http://linguistics.ucla.edu/general/dissertations/GarrettEdwardDissertationUCLA2001.pdf>. Last accessed Nov. 30, 2020.
- Ghulam Hassan Lobsang. 1995. *Short sketch of Balti grammar. A Tibetan dialect spoken in Northern Pakistan*. Bern: Universität Bern [Universität Bern, Institut für Sprachwissenschaft, Arbeitspapier, 34].
- Grzech, Karolina. 2016. “The non-evidential meaning of the Tena Kichwa ‘direct evidential’”. *PARLAY Proceedings, York Papers in Linguistics* 3: 73–94. <http://bit.ly/yplpv03-6>. Accessed Feb. 09, 2020.
- Grzech, Karolina. 2020. “Fieldwork on epistemic authority markers: What we can learn from different types of data”. *Folia Linguistica* 54.2: 405–445. <https://doi.org/10.1515/flin-2020-2046>. Accessed Jan 26, 2023.
- Häsler, Katrin Louise. 2001. “An empathy-based approach to the description of the verb system of the Dege dialect of Tibetan”. In: Bickel, Balthasar (ed.), *Person and evidence in Himalayan languages*. Part II. Special issue of *Linguistics of the Tibeto-Burman Area* 24.1: 1–34.
- Haller, Felix. 2004. *Dialekt und Erzählungen von Themchen* (Dialect of, and tales from Themchen). Bonn: VGH Wissenschaftsverlag [Beiträge zur tibetischen Erzählforschung, 14].
- Hargreaves, David. 2005. “Agency and intentional action in Kathmandu Newar”. *Himalayan Linguistics* 5: 1–48.
- Hargreaves, David. 2017. “‘Am I blue?’ Privileged access in Kathmandu Newar”. In: Floyd, Simeon; Norcliffe, Elisabeth; and San Roque Lila (eds.), *Egophoricity*, 79–107. Amsterdam, Phil.: Benjamins [Typological Studies in Language, 118]. <https://doi.org/10.1075/tsl.118.02har>. Accessed Dec. 30, 2020.
- Haspelmath, Martin. 2007. “Pre-established categories don’t exist: Consequences for language description and typology”. *Linguistic Typology* 11: 119–132. <https://doi.org/10.1515/LINGTY.2007.011>. Accessed Feb. 2, 2024.
- Haspelmath, Martin. 2020. “The structural uniqueness of languages and the value of comparison for language description”. *Asian Languages and Linguistics* 1.2: 346–366. <https://doi.org/10.1075/alal.20032.has>. Accessed Feb. 3, 2024.

- Hein, Veronika. 2001. "The role of the speaker in the verbal system of the Tibetan dialect of Tabo/Spiti". *Linguistics of the Tibeto-Burman Area* 24.1: 35–48.
- Hein, Veronika. 2007. "The mirative and its interplay with evidentiality in the Tibetan dialect of Tabo (Spiti)". *Linguistics of the Tibeto-Burman Area* 30.2: 195–214.
- Hein, Veronika. 2017. "Some remarks on Tabo Tibetan – A variety of the Tibetic language of Spiti". *Revue d'Etudes Tibétaines* 41: 111–127.
- Hengeveld, Kees; and Dall'Aglio Hattner, Marize Mattos. 2015. "Four types of evidentiality in the native languages of Brazil". *Linguistics* 53.3: 479–524. <https://doi.org/10.1515/ling-2015-0010>. Accessed Oct. 31, 2016.
- Heritage, John. 2012. "Epistemics in action: Action formation and territories of knowledge". *Research on Language & Social Interaction* 45.1: 1–29. <https://doi.org/10.1080/08351813.2012.646684>. Accessed Aug. 05, 2021.
- Herrmann, Silke. No date. *Sheldan Lhamo. Erzählung und Dialekt von Purik* (Narration from, and dialect of, Purik) [unpublished typescript].
- Hill, Nathan W. 2012. "'Mirativity' does not exist: *hdug* in 'Lhasa' Tibetan and other suspects". *Linguistic Typology* 16: 389–433. <https://doi.org/10.1515/lingty-2012-0016>. Accessed Feb. 02, 2013.
- Hill, Nathan W. 2017. "Perfect experiential constructions: the inferential semantics of direct evidence". In: Gawne, Lauren; and Hill, Nathan W. (eds.), *Evidential systems of Tibetan languages*, 131–159. Berlin, Boston: De Gruyter Mouton [Trends in Linguistics, Studies and Monographs, 302]. (<https://doi.org/10.1515/9783110473742-005>).
- Hill, Nathan W. 2020. Book Review. "*Egophoricity*. Simeon Floyd, Elisabeth Norcliffe, and Lila San Roque, eds." *Linguistic Typology* 24.1: 201–208. <https://doi.org/10.1515/lingty-2020-2035>. Accessed Feb. 29, 2020.
- Hintz, Daniel J. 2012. "Building common ground: The evidential category of mutual knowledge". Presentation given at the conference *The Nature of Evidentiality*, Leiden University, June 14–16, 2012.
- Hintz, Daniel J.; and Hintz, Diane M. 2014/2017.¹⁰⁸ "The evidential category of mutual knowledge in Quechua. *Lingua* 186–187: 88–109. <https://doi.org/10.1016/j.lingua.2014.07.014>. Accessed Jul. 28, 2021.
- Hongladarom, Krisadawan. 1993. "Semantic peculiarities of Tibetan verbs of being". In: Luksaneeyanawin, S. (ed.), *Proceedings of the Third International Symposium on Language and Linguistics, Bangkok, Thailand 1982*, vol. III, 1151–1162. Accessed Feb. 6, 2020 from <http://sealang.net/sala/archives/pdf8/hongladarom1992semantic.pdf>. [Bibliographical information from library catalogues and the author's website: <http://pioneer.netserv.chula.ac.th/~hkrisada/www/pandp.htm>].
- Honkasalo, Sami. 2019. *A grammar of Eastern Geshiza. A culturally anchored description*. Doctoral dissertation, Faculty of Arts of the University of Helsinki. <https://helda.helsinki.fi/bitstream/handle/10138/307585/Geshiza.pdf>. Accessed Aug. 03, 2021.
- Huber, Brigitte. 2005. *The Tibetan dialect of Lende (Kyirong)*. Bonn: VGH Wissenschaftsverlag [Beiträge zur tibetischen Erzählforschung, 15].

¹⁰⁸ The volume counts as published in 2017, but it is explicitly stated "Available online 20 August 2014".

- Huterer, Andrea. 2007. "Wir armen Schlawiner: Klagelied eines slavischen Lehnworts" (We pitiable Schlawiners: lament of a Slavonic loan word). *Der Osten im Westen – Importe der Populärkultur. Osteuropa* 57.5: 229–234.
- Hyslop, Gwendolyn; and Karma Tshering. 2017. "An overview of some epistemic categories in Dzongkha". In: Gawne, Lauren; and Hill, Nathan W. (eds.), *Evidential systems of Tibetan languages*, 351–365. Berlin, Boston: De Gruyter Mouton [Trends in Linguistics, Studies and Monographs, 302]. (<https://doi.org/10.1515/9783110473742-011>)
- Jones, Eunice. 2009. *Evidentiality and mirativity in Balti*. MA dissertation, School of Oriental and African Studies, University of London. (https://www.academia.edu/41938677/SCHOOL_OF_ORIENTAL_AND_AFRICAN_STUDIES_Evidentiality_and_Mirativity_in_Balti.)
- de Jong, Jan Willem. 1959. *Mi la ras pa'i rnam thar: Texte tibétain de la vie de Milarépa*. 'S-Gravenhage: Mouton.
- Kamio, Akio. 1997. *Territory of information*. Amsterdam: Benjamins [Pragmatics & Beyond New Series, 48].
- Kittilä, Seppo. 2019. "General knowledge as an evidential category". *Linguistics* 57.6: 1271–1304. <https://doi.org/10.1515/ling-2019-0027>. Accessed Mar. 03, 2021.
- Koshal, Sanyukta. 1979. *Ladakhi grammar*. Delhi, Varanasi, Patna: Motilal Banarsidass.
- Kretschmar, Monika. 1995. *Erzählungen und Dialekt aus Südmustang*. Vol. I. *Untersuchung zur Grammatik des Südmustang-Dialekts* (Dialect of, and tales from, South Mustang. Vol. 1. Investigation of the grammar of the dialect of South Mustang). Bonn: VGH Wissenschaftsverlag [Beiträge zur tibetischen Erzählforschung, 12/1].
- Mahimabhaṭṭa, Rājānaka (11th c.), ed. T. Gaṇapati Śāstrī. 1909. *The Vyaktiviveka of Rājānaka Mahimabhatta and its commentary of Rājānaka Ruṃyaka*. Trivandrum: Travancore Government Press [Trivandrum Sanskrit Series, 5].
- Maier, Emar. 2019. "On the exceptionality of reported speech". *Linguistic Typology* 23.1: 197–205. <https://doi.org/10.1515/lingty-2019-0009>. Accessed Feb. 05, 2021.
- Malcolm, Norman. 1991. "The relation of language to instinctive behaviour". In: Hyman, John (ed.), *Investigating psychology. Sciences of the mind after Wittgenstein*, 27–47. London, New York: Routledge.
- Matilal, Bimal Krishna. 1990. *The word and the world. India's contribution to the study of language*. Delhi: Oxford University Press. [Reprint 2001].
- Mélaç, Eric. 2014. *L'évidentialité en anglais. Approche contrastive à partir d'un corpus anglais – tibétain*. Thèse de doctorat (Evidentiality in English. A contrastive approach based on an English-Tibetan corpus. PhD thesis). Université Sorbonne Nouvelle – Paris 3. <https://theses.hal.science/tel-01230545/document>. Last accessed Mar. 18, 2023.
- Michael, Lev. 2020. "Rethinking the communicative functions of evidentiality: Event responsibility in Nanti (Arawakan) evidential practice". *Cadernos de Etnolingüística* 8.1: 95–123. <http://www.etnolingüística.org/article:vol8n1-3>. Accessed Jan. 12, 2023.
- Murray, Sarah E. 2010. *Evidentiality and the structure of speech acts*. New Brunswick, Newark, Camden: Rutgers, The State University of New Jersey [Graduate School - New Brunswick Electronic Theses and Dissertations]. <https://doi.org/10.7282/T3RX9BTJ/> or <https://rucore.libraries.rutgers.edu/rutgers-lib/30277/>. Accessed May 25, 2021.

- Nuyts, Jan. 2001. "Subjectivity as an evidential dimension in epistemic modal expressions". In: Dendale Patrick; and Tasmowski, Liliane (eds.), *Evidentiality*. Special issue of *Journal of Pragmatics* 33.3: 383–400. [https://doi.org/10.1016/S0378-2166\(00\)00009-6](https://doi.org/10.1016/S0378-2166(00)00009-6). Accessed Mar. 31, 2012.
- Oisel, Guillaume. 2013. *Morphosyntaxe et sémantique des auxiliaires et des connecteurs du tibétain littéraire. Étude diachronique et synchronique*. Thèse de doctorat (Morphosyntax and semantics of the auxiliaries and connective morphemes of Literary Tibetan. A diachronic and synchronic study. Doctoral thesis). Laboratoire du LACITO – CNRS. <https://theses.hal.science/tel-00914393/document>. Last accessed Mar. 18, 2023.
- Oisel, Guillaume. 2017. "Re-evaluation of the evidential system of Lhasa Tibetan and its atypical functions". *Himalayan Linguistics* 16.2: 90-128. <https://escholarship.org/uc/item/9v08z3b4>. Accessed Mar. 28, 2017.
- Palmer, Frank R. 1996. *Mood and modality*. Cambridge: Cambridge University Press [Cambridge Textbooks in Linguistics]. [Second edition 2001].
- Pandey, Anshuman. 2011. "Preliminary proposal to encode the Balti 'B' script in ISO/IEC 10646." <http://std.dkuug.dk/JTC1/SC2/WG2/docs/n4016.pdf>. Accessed Aug. 15, 2023.
- Peterson, J. 2000. "Evidentials, inferentials and mirativity in Nepali". *Linguistics of the Tibeto-Burman Area* 23.2: 13–37.
- Plungian, V.A. 2010. "Types of verbal evidentiality marking: an overview". In: Diewald, Gabriele; and Smirnova, Elena (eds.), *Linguistic realization of evidentiality in European languages*, 15–58. Berlin: Mouton de Gruyter [Empirical Approaches to Language Typology, 49].
- Read, Alfred F. 1934. *Balti Grammar*. London: Royal Asiatic Society.
- San Roque, Lila; and Loughnane, Robyn. 2012. "The New Guinea Highlands evidentiality area". *Linguistic Typology* 16: 111–167. Originally accessed from <https://doi.org/10.1515/lingty-2012-0003>, Jan. 29, 2015. [Now available under <https://doi.org/10.1515/lity-2012-0003>].
- Sandmann, Erika. 2019. "Ego evidential *-yek* as a stance marker in Wutun: evidence from conversational data". Presentation given at the international workshop *'Evidentiality' in Tibetic languages and beyond – a closer look*. Tübingen, 16-17 February 2019.
- de Saussure, Ferdinand. 1916. *Cours de linguistique générale*. Publié par Charles Bailly [! read Bally] et Albert Séchehaye avec la collaboration de Albert Riedlinger. Édition critique préparée par Tullio de Mauro (Course in general linguistics. Edited by Charles Bally and Albert Sechehaye in collaboration with Albert Riedlinger. Critical edition prepared by Tullio de Mauro) Paris: Éditions Payot & Rivages. [Third edition, 1995. Reprint 2000].
- de Saussure, Ferdinand. 1959. *Course in general linguistics*. Edited by Charles Bally and Albert Sechehaye. In collaboration with Albert Reidlinger [!]. Translated from the French by Wade Baskin. New York: Philosophical Library.
- Schuler, Sidney. 1978. "The 'story of the creation of Shigar' of Wazi Ahmad". *Central Asian Journal* 22.1–2: 102–120.
- Shao Mingyuan. 2016. "Zangyuzu xidongci red de yufahua – 藏語組繫動詞 red 的語法化 (The grammaticalization of the copula verb *red* in Tibetic languages)". *Language and Linguistics* 17.5: 1–38. <https://doi.org/10.1177/1606822X16645742>. Accessed Apr. 01, 2020.
- Simon, Camille. 2019. "Negotiating the facts: interactional functions of factual evidential markers in Amdo-Tibetan". Presentation given at the international workshop *'Evidentiality' in Tibetic languages and beyond – a closer look*. Tübingen, 16-17 February 2019.

- Simon, Camille; and Hill, Nathan W. 2015. "Tibetan". In: Grandi, Nicola; and Körtvélyessy, Livia (eds.), *Edinburgh handbook of evaluative morphology*, 381–388. Edinburgh: Edinburgh University Press.
- Stenzel, Kristine. 2008. "Evidentials and clause modality in Wanano". *Studies in Language* 32.2: 405–445. <https://doi.org/10.1075/sl.32.2.06ste>. Accessed Dec. 30, 2020.
- Stivers, Tanya; Mondada, Lorenza; and Steensig, Jakob. 2011. "Knowledge, morality and affiliation in social interaction". In: Stivers, Tanya; Mondada, Lorenza; and Steensig, Jakob (eds.), *The morality of knowledge in conversation*, 3–24. Cambridge, Mass.: Cambridge University Press. (<https://doi.org/10.1017/CBO9780511921674.002>).
- Sun, Jackson-Tianshan. 1993. "Evidentials in Amdo Tibetan". *Bulletin of the Institute of History and Philology, Academia Sinica* 63.4: 143–188.
- Sun, Jackson-Tianshan. 2018. Evidentials and person. In: Aikhenvald, Alexandra Yurievna (ed.), *The Oxford handbook of evidentiality*, 47–63. Oxford: Oxford University Press [Oxford Handbooks in Linguistics].
- Suzuki, Hiroyuki. 2017. "The evidential system of Zhollam Tibetan". In: Gawne, Lauren; and Hill, Nathan W. (eds.), *Evidential systems of Tibetan languages*, 423–444. Berlin; Boston: De Gruyter Mouton [Trends in Linguistics, Studies and Mono-graphs, 302]. (<https://doi.org/10.1515/9783110473742-013>)
- Suzuki, Hiroyuki; Sonam Wangmo; and Tsering Samdrup. 2021. "A contrastive approach to the evidential system in Tibetic languages: examining five varieties from Khams and Amdo". *言語研究 Gengo Kenkyu (Journal of the Linguistic Society of Japan)* 159: 69–101. https://doi.org/10.11435/gengo.159.0_69; https://www.jstage.jst.go.jp/article/gengo/159/0/159_69/article/-char/en. Accessed Jun. 12, 2021.
- Takeuchi, Tsuguhito. 1990. "Chibetto-go no jutsubu ni okeru jodōshi no kinō to sono hattatsu katei – チベット語の述部における助動詞の機能とその発達過程" (The function of auxiliary verbs in Tibetan predicates and their historical development). In: Sakiyama and Sato (eds.), *Asia no Syo-gengo to Ippann-gengogaku, アジアの諸言語と一般言語学* (Various Asian languages and general linguistics), 6–16. Tokyo: Sanseido. (Cited after Takeuchi 2015.)
- Takeuchi, Tsuguhito. 2015. "The function of auxiliary verbs in Tibetan predicates and their historical development". *Revue d'Études Tibétaines* 31: 401–415. [English translation of Takeuchi 1990]. https://himalaya.socanth.cam.ac.uk/collections/journals/ret/pdf/ret_31_25.pdf. Accessed May 19, 2016.
- Tantucci, Vittorio. 2013. "Interpersonal evidentiality: The Mandarin V-过 *guo* construction and other evidential systems beyond the 'source of information'". *Journal of Pragmatics* 57: 210–230. <https://doi.org/10.1016/j.pragma.2013.08.013>. Accessed Oct. 10, 2016.
- Tantucci, Vittorio. 2016. "Toward a typology of constative speech acts: Actions beyond evidentiality, epistemic modality, and factuality". *Intercultural Pragmatics* 13.2: 181–209. <https://doi.org/10.1515/ip-2016-0008>. Accessed Mar. 06, 2021.
- Taube, Manfred, 1978. "Zu einigen Texten der brda-gsar-rñiñ-Literatur (On some texts of the brda-gsar-rñiñ literature)". In: Richter, Eberhardt; and Taube, Manfred (eds.), *Asienwissenschaftliche Beiträge: Johannes Schubert in memoriam* (Contributions to Asian Studies, in memory of Johannes Schubert), 169–201. Berlin: Akademie-Verlag [Veröffentlichungen des Museums für Völkerkunde zu Leipzig, 32].

- Tournadre, Nicolas. 2008. “Arguments against the concept of ‘conjunct’/‘disjunct’ in Tibetan”. In: Huber, Brigitte; Volkart, Marianne; and Widmer, Paul (eds.), *Chomolangma, Demawend und Kasbek. Festschrift für Roland Bielmeier zu seinem 65. Geburtstag. Band I: Chomolangma* (Chomolangma, Demawend and Kasbek. Festschrift for Roland Bielmeier on his 65th birthday. Vol. 1 Chomolangma), 281–308. Halle: International Institute for Tibetan and Buddhist Studies.
- Tournadre, Nicolas. 2021. “The status of egophoric markers within the Tibetic evidential-epistemic systems”. Keynote talk at the online conference *Evidentiality and modality: At the crossroads of grammar and lexicon*, Montpellier, June 10–11, 2021.
- Tournadre, Nicolas; and Sangda Dorje. 1998. *Manuel de tibétain standard, langue et civilisation*. བོད་ཀྱི་སྐད་སྒྲིག་ཐོབ་ཤིང་། (Manual of Standard Tibetan, language and civilisation). Paris: Langues & Mondes / L’Asiatheque.
- Tournadre, Nicolas; and Suzuki, Hiroyuki. 2023. *The Tibetic Languages. An introduction to the family of languages derived from Old Tibetan*. ལྷོ་མཁའ་ལྗོངས་བོད་ཀྱི་སྐད་ཡིག་རྒྱུ་རྩུ་བའི་སྐད་རིགས་ཀྱི་ཁྱིམ་རྒྱུད་ལ་འཇུག་པ་རབ་གསལ་མ་ལོང་། Villejuif: Lacito-Publications [Diversité des langues, 2]. <http://lacito-publications.cnrs.fr>. Accessed Sep. 14, 2023.
- Tribur, Zoe. 2017. “Observations on factors affecting the distributional properties of evidential markers in Amdo Tibetan”. In: Gawne, Lauren; and Hill, Nathan W. (eds.), *Evidential systems of Tibetan languages*, 367–421. Berlin; Boston: De Gruyter Mouton [Trends in Linguistics, Studies and Monographs, 302]. (<https://doi.org/10.1515/9783110473742-012>).
- Tribur, Zoe. 2019. *Verbal morphology of Amdo Tibetan*. PhD dissertation, University of Oregon. Ann Arbor, MI: ProQuest. ProQuest: 22623552, <https://www.proquest.COM/docview/2309795193/5115BEC20F524267PQ/1?accountid=14433>. Accessed Feb. 22, 2021.
- Volkart, Marianne. 2000. “The meaning of the auxiliary morpheme ‘*dug* in the aspect systems of some Central Tibetan dialects”. In: Bickel, Balthasar (ed.), *Person and evidence in Himalayan languages*. Part I. Special issue of *Linguistics of the Tibeto-Burman Area* 23.2: 127–153.
- Watters, Stephen. 2021. “Egophoricity in Dzongkha: speaker representation of knowledge and interlocutor accessibility”. Presentation given at the online conference *Evidentiality and modality: At the crossroads of grammar and lexicon*, Montpellier, June 10–11, 2021.
- Weinrich, Harald. 1964. *Tempus. Besprochene und erzählte Welt* (Tense. Discussed and narrated world). Stuttgart etc.: Kohlhammer [Sprache und Literatur, 16]. [4th edition 1985].
- Widmer, Manuel. 2020. “Same same but different: On the relationship between egophoricity and evidentiality”. In: Henrik Bergqvist and Seppo Kittilä (eds.), *Evidentiality, egophoricity, and engagement*, pp. 263–287. Berlin: Language Science Press [Studies in Diversity Linguistics, 30]. <https://doi.org/10.5281/zenodo.3968344>. Accessed Sep. 14, 2020.
- Yliniemi, Juha. 2019. *A descriptive grammar of Denjongke (Sikkimese Bhutia)*. PhD thesis, University of Helsinki & Sikkim University. <https://researchportal.helsinki.fi/en/publications/a-descriptive-grammar-of-denjongke-sikkimese-bhutia>. Accessed Nov. 22, 2019.
- Zeisler, Bettina. 2004. *Relative tense and aspectual values in Tibetan languages. A comparative study*. Berlin, New York: Mouton de Gruyter [Trends in Linguistics, Studies and Monographs, 150]. [E-book version 2011, <https://doi.org/10.1515/9783110908183>].
- Zeisler, Bettina. 2010. “East of the moon and west of the sun? Approaches to a land with many names, north of ancient India and south of Khotan”. In: Vitali, Roberto (ed.) *The Earth Ox papers. Proceedings of the International Seminar on Tibetan and Himalayan Studies, held at the*

- Library of Tibetan Works and Archives, September 2009 on the occasion of the 'Thankyou India' year.* Special issue of *The Tibet Journal* 34.3-4/35.1-2: 371-463.
- Zeisler, Bettina. 2011. "Kenhat, the dialects of Upper Ladakh and Zanskar". In: Turin, Mark; and Zeisler, Bettina (eds.), *Himalayan languages and linguistics*. Studies in phonology, semantics, morphology and syntax, 235-301. Leiden etc.: Brill [Brill's Tibetan Studies Library, 5/12].
- Zeisler, Bettina. 2017a. "The emergence of the Ladakhi inferential and experiential markers out of a marker for admirativity (non-commitment): the case of *hdug* and *snay*". *Journal of South Asian Languages and Linguistics* 4.2: 259-307. (<https://doi.org/10.1515/jsall-2017-0009>).
- Zeisler, Bettina. 2017b. "Don't believe in a paradigm that you haven't manipulated yourself! – Evidentiality, speaker attitude, and admirativity in Ladakhi". In: Celle, Agnès; and Tsangalidis, Anastasios (eds.), *The linguistic expression of mirativity*. Special issue of *Review of Cognitive Linguistics* 15.2: 515-539. (<https://doi.org/10.1075/rcl.15.2.09zei>).
- Zeisler, Bettina. 2018a. "Don't believe in a paradigm that you haven't manipulated yourself! – Evidentiality, speaker attitude, and admirativity in Ladakhi (extended version)". *Himalayan Linguistics* 17.1: 67-130. (<https://escholarship.org/uc/item/8jq4t1ww>).
- Zeisler, Bettina. 2018b. "Evidence for the development of 'evidentiality' as a grammatical category in the Tibetic languages". In: Foolen, Ad; de Hoop, Helen; and Mulder, Gijs (eds.), *Evidence for evidentiality*. Special issue of *Human Cognitive Processing (HCP)* 61: 227-256. (<https://doi.org/10.1075/hcp61.10zei>).
- Zeisler, Bettina. 2022a. "To be or not to be: On the Modern Tibetan auxiliary verb *red* in classical texts". *Himalayan Linguistics* 21.3: 50-84. (<https://doi.org/10.5070/H921352173>).
- Zeisler, Bettina. 2022b. "Of gold, ants, and other fables concerning the 'Dards' of Ladakh (and Baltistan)". In: Cüppers, Christoph; Everding, Karl-Heinz; and Schwieger, Peter (eds.), *A life in Tibetan studies. Festschrift for Dieter Schuh at the occasion of his 80th birthday*, 705-764. Lumbini: Lumbini International Research Institute.
- Zeisler, Bettina. 2023. "Evidential-perceptual transfer by a blind speaker? Or: what do the Ladakhi markers for "visual" and "non-visual" perceptual experience, *hdug* and *rag*, actually encode?" *Journal of South Asian Languages and Linguistics* 9.1-2: 131-157. (<https://doi.org/10.1515/jsall-2023-1006>).
- Zemp, Marius. 2013. *A historical grammar of the Tibetan dialect spoken in Kargil (Purik)*. PhD-thesis, University of Berne.
- Zemp, Marius. 2017. "The origin and evolution of the opposition between testimonial and factual evidentials in Purik and other varieties of Tibetan". *Open Linguistics* 3: 613-637. <https://doi.org/10.1515/opli-2017-0031>. Accessed Dec. 04, 2018.
- Zemp, Marius. 2018. *A Grammar of Purik Tibetan*. Leiden/ Boston: Brill [Brill's Tibetan Studies Library, 21; Languages of the Greater Himalayan Region]. (<https://doi.org/10.1163/9789004366312>).
- Zhang Yisun (ཇམ་འཕྱི་ལུན་ / 張怡蓀) (ed.) 1993. བོད་རྒྱ་ཚིག་མཛོད་ཆེན་མོ། རྫོང་ཆ། ལྷན་ཆ། བེ་ཅིན། མི་རིགས་དཔེ་སྟུན་ཁང་། / 藏漢大辭典 (The large Tibetan-Chinese dictionary. Vol. 1-2. Beijing: Nationalities Press).