

RESEARCH

Chemically Enhanced Treatment Wetland to Improve Water Quality and Mitigate Land Subsidence in the Sacramento–San Joaquin Delta: Cost and Design Considerations

Philip A.M. Bachand,^{*1} Tamara E.C. Kraus,² William R. Horwath,³ Nathan R Hatch,¹ Sandra M. Bachand¹

ABSTRACT

Water quality impairment and land surface subsidence threaten the viability of the Sacramento–San Joaquin Delta (Delta), a critical component of California’s water conveyance system. Current-day irrigation drainage through Delta island peat soils affects drinking water treatment and is linked to mercury transport, potentially posing both ecological and public health concerns. To cost-effectively treat agricultural drainage water from subsided Delta islands to reduce the export of drinking Water Quality Constituents of Concern and mitigate land subsidence through accretion, we studied hybrid coagulation-treatment wetland systems, termed Chemically Enhanced Treatment Wetlands (CETWs). We provide cost estimates and design recommendations to aid broader implementation of this technology. Over a 20-year horizon

using a Total Annualized Cost analysis, we estimate treatment costs of \$602 to \$747 per acre-foot (ac-ft) water treated, and \$36 to \$70 per kg dissolved organic carbon (DOC) removed, depending upon source water DOC concentrations for a small 3-acre CETW system. For larger CETW systems scaled for island sizes of 3,500 to 14,000 acres, costs decrease to \$108 to \$239 per ac-ft water treated, and \$11 to \$14 per kg DOC removed. We estimated the footprints of CETW systems to be approximately 3% of the area being treated for 4-day hydraulic retention time (HRT) systems, but they would decrease to less than 1% for 1-day HRT systems. CETWs ultimately address several of the Delta’s key internal issues while keeping water treatment costs competitive with other currently available treatment technologies at similar scales on a per-carbon-removed basis. CETWs offer a reliable system to reduce out-going DOC and mercury loads, and they provide the additional benefit of sediment accretion. System costs and treatment efficacy depend significantly on inflow source water conditions, land availability, and other practical matters. To keep costs low and removal efficacy high, wetland design features will need site-specific evaluation.

SFEWS Volume 17 | Issue 3 | Article 1

<https://doi.org/10.15447/sfeWS.2019v17iss3art1>

* Corresponding author: philip@bachandassociates.com

1 Bachand & Associates
Davis, CA 95618 USA

2 California Water Science Center
U.S. Geological Survey
Sacramento, CA 95819 USA

3 Department of Land, Air, and Water Resources
University of California, Davis
Davis, CA 95616 USA

KEY WORDS

coagulation; hybrid treatment wetland; *in situ* water treatment; dissolved organic carbon;

mercury; disinfection byproducts; nutrients; cost analysis; treatment system design; land accretion

INTRODUCTION

The Sacramento–San Joaquin Delta (Delta) provides immense value to California as a freshwater conduit for 750,000 acres of farmland, primarily in the Central Valley, and raw drinking water supply for nearly two-thirds of Californians (Fujii 1998; Lund et al. 2008; Luoma et al. 2015; PPIC 2016). The Delta faces continuing ecological and structural challenges, including numerous threatened and endangered fish species (Lund et al. 2010; Murphy et al. 2011), land subsidence from peat oxidation that increases levee failure risks (Mount and Twiss 2005; Deverel et al. 2016a), and water quality issues that require the management of salinity, dissolved organic carbon (DOC), disinfection byproduct precursors (DBPPs), and mercury (Hg) (Kraus et al. 2008; Ackerman et al. 2014; Medellin–Azuara et al. 2014; Henneberry et al. 2016; Hansen et al. 2018). These challenges have spawned a broad range of studies and strategies to develop solutions, though improvements in one area can create challenges that exacerbate another. For instance, wetland expansion and rice cultivation have been considered as alternative land uses to combat subsidence by promoting—through flooding—more reduced conditions that prevent peat oxidation (Deverel and Rojstaczer 1996). However, if not managed carefully, these conditions can increase DOC and methylmercury (MeHg) exports from island drains into the Delta waterways (Fleck et al. 2007; Ackerman et al. 2015; Bachand et al. 2018). DOC is a drinking water concern because it reacts with chlorine to produce disinfection byproducts (DBPs), and methylmercury is a hazardous substance. The California Department of Water Resources, the U.S. Army Corps of Engineers, and local reclamation districts have spent significant resources on strengthening levee systems to combat water intrusion from surrounding waterways. However, continued farming has led to greater land subsidence that exacerbates levee instability by creating larger hydraulic pressure heads between the island surface and the adjacent water bodies (Deverel et al. 2015). Levee failure risks may still increase

over time as a result of continued subsidence and climate change-induced sea level rise (Deverel et al. 2016a).

Chemically Enhanced Treatment Wetlands (CETWs)—hybrid coagulation–treatment wetland systems (Appendix A, Figure A1) that leverage chemical and biogeochemical processes to improve water quality by removing Water Quality Constituents of Concern (WQCCs)—have been considered as a potential water quality and subsidence remedy. As a general water treatment approach, coagulation has advanced beyond drinking water applications and been used for removal of colloidal solids, algae, heavy metals, nutrients, bacteria, and fine particles in solution (Smeltzer 1990; Harper 1994; Welch and Schriever 1994; Harper et al. 1998; Rydin and Welch 1998; Welch and Cooke 1999; Aguilar et al. 2002; Leggiere 2004; Macpherson 2004; Lee and Westerhoff 2006; El Samrani et al. 2008; Akbal and Camcı 2010; De Parsia et al. 2019). Additionally, coagulation has been applied to remove DOC and nutrients from lakes, reservoirs, and estuaries (Berger 1987; Croué et al. 1993; Volk et al. 2000; Bratby 2006; Metcalf and Eddy 2009). Treatment wetlands are engineered to improve water quality by using natural wetland processes such as sedimentation, biological uptake, microbial activity, and sorption by wetland components through the selection of soil, vegetation, and hydrologic controls (Hammer 1989; Haberl et al. 2003). Combining chemical coagulation with treatment wetlands allows them to work synergistically through replacement of the sedimentation, clarification, and filtration processes typical in water treatment plants with similar wetlands processes.

Application of CETWs is relatively novel. Thus far, these systems have been tested for fine particle and dissolved phosphorus removal at smaller scales in stormwater treatment mesocosm studies (Bachand et al. 2000, 2006, 2007; Trejo–Gaytan et al. 2006); potential toxicity to green algae, zooplankton, larval Fathead Minnow, and Japanese Medaka (Lopus et al. 2009; Bachand et al. 2010a); and treatment feasibility and design considerations (Bachand et al. 2010b). These previous studies have demonstrated this



Figure 1 Aerial view of Twitchell Island with the white box indicating the location of the replicated field study (Google Earth Pro 7.3, 2017), and to the right a schematic of the replicated treatment block design. Co indicates untreated control treatment, Fe indicates Fe treatment, Al indicates Al treatment.

technology to be successful for fine particle and phosphorus removal, with potential toxicity avoided by dosing coagulants at levels optimal to achieve water quality treatment goals or lower. Under CETW systems, coagulant dosing occurred before drainage water entered the wetlands. Dissolved WQCCs—such as DOC and mercury—aggregate and precipitate as settleable flocs, which are then retained in the wetlands (Henneberry et al. 2011; Stumpner et al. 2015; Liang 2016; Hansen et al. 2018). For subsided lands, the retained flocs accelerate sediment accretion (Stumpner et al. 2018). Here, we summarize findings from recent larger-scale Delta CETW applications, discuss the implications, and provide design recommendations and cost estimates for these hybrid systems. An important goal of this paper is to integrate those findings, so that land use managers can understand the potential costs and benefits of implementing CETWs in the Delta.

METHODS

Performance Testing and Assessing Processes

CETWs were implemented, using three replicates for each treatment, on a highly subsided island (Twitchell Island, Figure 1) located in the Sacramento–San Joaquin Delta, CA. Each wetland cell was approximately 40 feet (12.2 m) wide and 120 ft (36.6 m) long, for an area of approximately 4,800 ft² (446 m², 0.0446 hectares, 0.11 acres) and length-to-width ratios of 3:1. Wetlands were operated at a water depth of approximately 1.5 ft (0.45 m), and volumetric flow rates of 0.5–75.1 cubic feet per second (cfs), designed for a target hydraulic retention time (HRT) of 3–5 days, which corresponds to hydraulic loading rates of 4.4–4.5 in d⁻¹ (11.2–11.4 cm d⁻¹). Ferric sulfate (Fe treatment, 60% Soln., Kemira Water Solutions, Inc., Finland) and polyaluminum chloride (PAC, Al treatment, PAX-XL19, Kemira Water Solutions, Inc., Finland) coagulants (Figure 2A) were dosed using peristaltic pumps (Figure 2B) and then rapidly mixed into island drainage water using static mixers (Figure 2C). The dosed water flowed through PVC piping systems, where in-line static

2.1

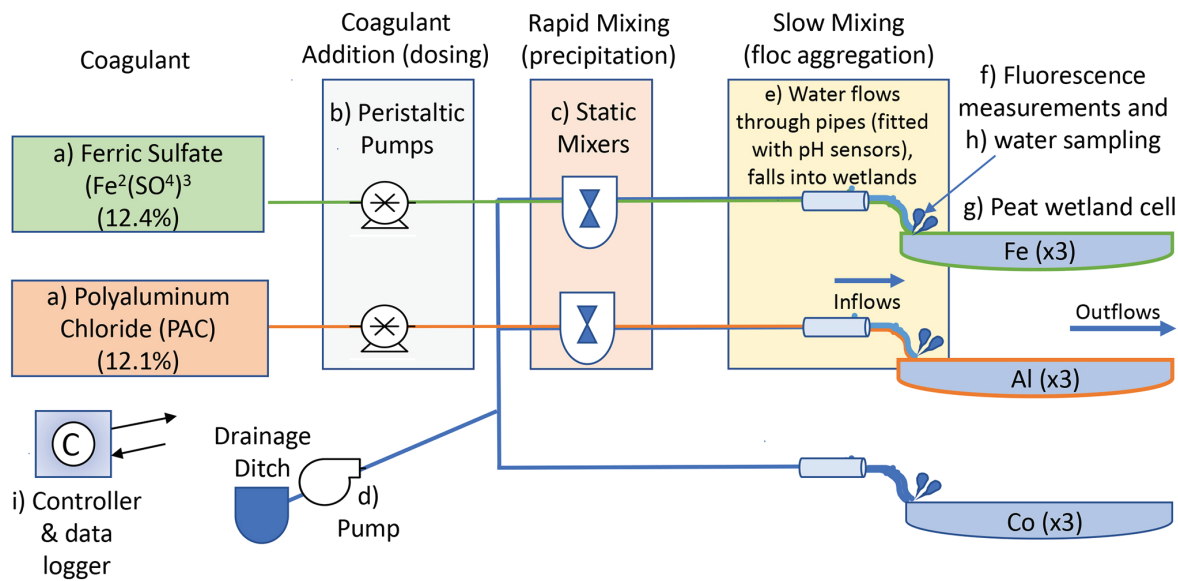

2.2

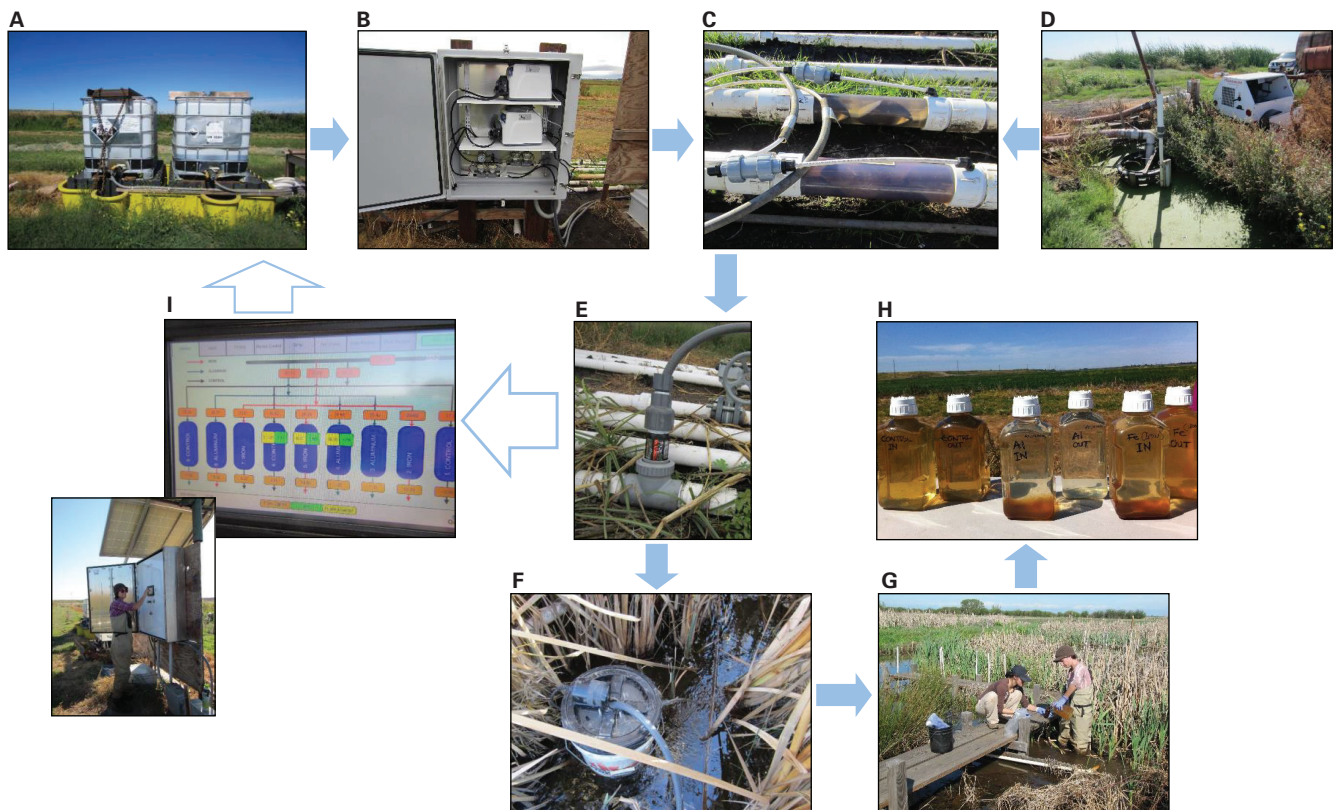

Figure 2 Chemically Enhanced Treatment Wetland (CETW) design schematic depicted using a flow chart (2.1) and pictorial guides (2.2). Coagulants stored in totes (A) were pumped via peristaltic pumps (B) to a static mixer (C) where chemicals were flash-mixed into source water pumped from an island drain ditch (D). Dosed water passed through pipes fitted with pH sensors (E) and entered wetlands, where it was measured for fluorescent dissolved organic matter (F). As water enters the wetland cells (G), samples were collected (H) to monitor performance and calibrate the system. Sensor measurements were fed back to the data logger and controller (I) to record data and to adjust water and chemical feeds.

mixers slowly mixed the water (Figure 2E), which entered the wetlands through inflow pipes. In-line magnetic flow meters measured flow rates, and fluorescent dissolved organic matter (FDOM) measurements and water quality samples were collected at the inflow (Figure 2F–2H). All sensor measurements were fed back to the data logger and controller (Figure 2J) to record data and to adjust water and chemical feeds. After entering the wetland cells, water flowed across the length of the wetland toward outflow pipes (opposite inflow pipes, where flow rates and water quality samples were also collected) and en route passed monitoring locations along a constructed boardwalk (Figure 2G). Water exiting outflow pipes discharged into canals that led to Twitchell Island's main drain, where water was pumped off the island back into Delta waterways. Control treatment wetlands and the piping system were identical to the coagulation (Fe and Al) treatment wetlands, except no chemicals were applied, and therefore no dosing or mixing hardware (i.e., peristaltic pumps, static mixers) was needed.

System construction—which included development of the coagulation system (flow and chemical control and monitoring), nine wetland cells within the study plot, and boardwalk infrastructure within the wetland cells—began in July 2008 and continued through January 2012 (Appendix A, Figures A2 and A3), with a 2-year interruption of funding. Once the system was operational, extensive hydrologic, dosing, and water quality monitoring (monitoring program) began for all nine wetlands. Inflow and outflow rates, coagulant dosing rates, FDOM concentrations (measured in-field on raw water samples used as a surrogate for DOC concentration), and pH at key flow diagnostic locations were monitored at 15-minute intervals and recorded using a Campbell data logger, available for local and remote download. Piping line pressure was monitored at the main pump to indicate irregular pressures (i.e., as a result of pipe clogging). The height of the outflow weirs controlled water levels in the wetlands, and water levels were recorded during weekly water sample collection. Water samples were collected weekly at the control treatment inflow (non-dosed), the coagulation treated inflows (post-dose), and all

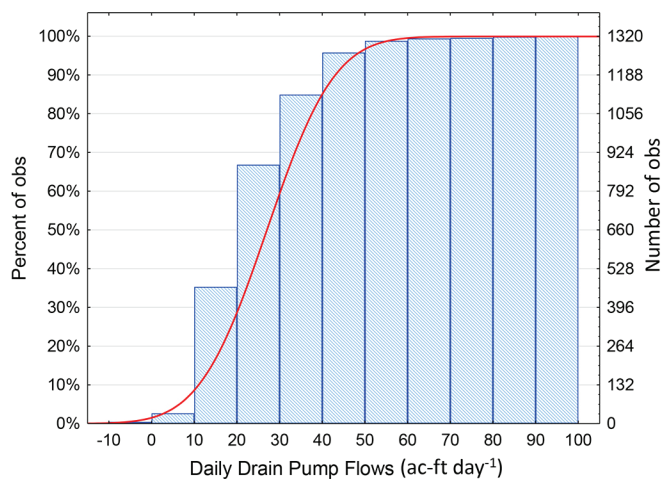

Figure 3 Cumulative histogram of flow rates exported off Twitchell Island via the main drain pumping station

outflows (outflow). Water was analyzed weekly for DOC, total suspended solids, total Fe, total Al, and UV254 (absorbance of ultraviolet light at 254 nm, used as another surrogate for DOC concentration measured in the laboratory after removing Fe interference) (Bachand et al. 2019a). In addition, YSI water quality sonde (Xylem Inc.) measurements were collected during weekly sampling events to monitor turbidity, pH, and dissolved oxygen (Bachand et al. 2019a). Nitrate, ammonia, dissolved organic nitrogen (DON), dissolved aluminum (DAI), dissolved iron (DFe), sulfate, chloride, and phosphates were analyzed monthly from selected weekly samples (Bachand et al. 2019a). Filtered and particulate fractions of MeHg and total Hg were analyzed monthly from samples collected using ultra-clean techniques according to the USGS National Field Manual (Wilde et al. 2004; Stumpner et al. 2015). DBPPs (indicated by haloacetic acid [HAA] and trihalomethane [THM] formation potentials) were analyzed three times throughout the field study on samples collected using ultra-clean methods in February, May, and July 2013 to represent winter, spring, and summer conditions, respectively (Hansen et al. 2018). The monitoring program was designed to (1) determine the effectiveness of CETWs for concentration and load reduction of key WQCC; (2) identify the effects of CETWs on the fate and transport of these key WQCC; and (3) develop best management practices and design

recommendations for CETWs to improve the quality of water discharged from Delta islands.

In addition to the aforementioned monitoring program, Liang et al. (2019) assessed vegetation in the wetlands to determine treatment effects, and Stumpner et al. (2018) sampled soils and detritus at the beginning and end of the field study at locations near the inflow, center, and outflow in all wetlands that represented a downstream gradient. Stumpner et al. (2018) also used soil and detritus data to assess the effects of coagulation on wetland accretion rates.

Design and Costs Analyses

Fundamental to implementing CETWs is an understanding of design alternatives and their associated costs. We defined four design alternatives to assess and compare costs. These alternatives were sized to represent relatively small CETWs of approximately three acres (Table 1, Alternative 1)—similar in scale to the entire study plot, which comprised 9 experimental treatment cells—to larger CETWs sized to treat drainage water from entire islands in the Delta (Table 1, Alternatives 3 and 4), such as Jersey Island (Alternative 3) and Sherman Island (Alternative 4). Length-to-width ratios, water depth, levee dimensions, and compaction ratios were based upon approaches or practices found in the literature or standard engineering design. Two key design parameters are critical to CETW sizing: wetland HRT and flow rate. Study HRT was targeted at 4 days based upon the reported settling times required for key WQCC removal (Bachand et al. 2000, 2010a, 2019b). Given that DOC removal targets were achieved in the study, this HRT was propagated into the design alternative assessment. We estimated design flow rate per acre based on observed monthly average flow rates for the Twitchell Island pump drain and the total area drained. A cumulative histogram of daily flow rates (Figure 3) was constructed based on monthly pump drain flow rate averages for years 2009–2012 exiting the main drain of the island (Appendix A, Figure A4). The 75th percentile daily flow rate of 36.5 ac-ft d⁻¹ was used as the design flow rate to represent reasonable pumping rates from Twitchell Island. Based upon Twitchell Island drained area (3,516

acres), the monthly design flow rate per acre is 0.315 ac-ft mo⁻¹ ac⁻¹. This design flow rate generally exceeded average monthly flow rates for all months except from December through February. We assumed treatable flow rates (ac-ft mo⁻¹) from an island area to be 0.315 × *Island Area (in acres)*.

We developed cost estimates for this study using several information sources. First, we tracked costs during the study, including capital expenditures for construction, monitoring, and instrumentation, as well as labor and materials for routine system operation and maintenance (O&M). We used this cost tracking, supplemented by other available information, to calculate project costs. Supplemental Information tables in Appendix A contain cost information for some project components such as boardwalk construction (Appendix A, Table A1; note that the level of boardwalk infrastructure for any future applications will depend on sampling needs for testing and monitoring, and therefore can be highly variable); pump station construction estimates (Appendix A, Table A2); agricultural land costs in the Delta (Appendix A, Table A3); and laboratory analysis costs (Appendix A, Table A4). Second, we used labor costs that utilized time estimates and competitive billing rates (Appendix A, Table A5) to estimate annual costs such as chemical system maintenance. Third, we assumed some costs to be a function of the total project capital. More details on cost development and assumptions are provided in the notes for Table 2.

We converted costs to both Present Value (PV) and Total Annualized Cost (TAC) in USD, assuming a 2% net interest rate and a 20-year life. We standardized costs against mass of DOC removed (\$ per kgDOC), water volumes treated (\$ per ac-ft), and area required (\$ per ac). We compared treatment technology in terms of TAC, a method often used to compare systems with different life-spans. For technologies that could be incorporated into an existing treatment plant (e.g., disinfection technologies), capital costs include only additions to the treatment plant and O&M specific to the technology, but not the costs of the treatment plant itself. We compared our

Table 1 Chemically Enhanced Treatment Wetland (CETW) Alternatives design summary

Design aspects	Alternatives (approximate wetted areas)				Units
	1	2	3	4	
Wetland design specification and calculations					
Wetland operational specifications					
L:W ratio	3	3	3	3	
Water depth	1.5	1.5	1.5	1.5	ft
Hydraulic retention time (HRT)	4	4	4	4	days
Wetland bed dimensions					
Width	200	600	1200	2400	ft
Length	600	1800	3600	7200	ft
Bed Area	2.8	24.8	99.2	396.7	acres
Wetland wetted dimensions					
Width	206	606	1206	246	ft
Length	606	1806	3606	7206	ft
Wetted area	2.9	25.1	99.8	398.0	acres
Wetland volume					
Wetted volume	183,627	1,630,827	6,501,627	25,963,227	ft ³
Hydrology					
Treatable flow rate ^a	1.05	9.36	37.31	149.01	ac-ft d ⁻¹
<i>Treatable area</i>					
Treatable acres ^b	102	902	3,598	14,368	acres
Wetland acres: treatable acres	2.8%	2.8%	2.8%	2.8%	%
Levee Design Specifications and Calculations					
Centerline dimensions					
Width (levee length of short sides)	226	626	1,226	2,426	ft
(levee length of long sides)	626	1,826	3,626	7,226	ft
Perimeter (total levee length)	1,704	4,904	9,704	19,304	ft
Levee cross-sections	All levees have 2:1 side slopes, 12 ft to width, 2 ft of free board, total levee height of 3.5 ft, and 26 ft bottom width.				
Earthwork					
Compacted	4,197	12,078	23,901	47,545	yd ³
Uncompacted ^c	5,246	15,098	29,876	59,431	yd ³
Total Area (including levee footprint)	3.2	26.2	102.1	402.4	acres
Wetted area / total CETW area	3%	96%	98%	99%	%

a. Calculated as (wetted volume) / HRT.

b. Treatable acres calculated using runoff flow of 0.315 ft mo⁻¹; 75th percentile of recorded monthly volumes of

c. Calculated assuming 80% compaction ratio.

Table 2 Cost summary in U.S. dollars by alternatives presented in [Table 1](#)

Cost category	Costs by alternative (in thousands)				Footnotes (see page 9)
	1	2	3	4	
Direct capital costs					
A. General					
a. Mobilization and demobilization	\$6.8	\$15.6	\$40.9	\$133.7	a
b. Surveying and mapping	\$3.5	\$5.2	\$13.6	\$44.6	b
c. Worker protection	\$2.3	\$5.2	\$13.6	\$44.6	c
d. Miscellaneous facilities	\$6.3	\$6.3	\$6.3	\$6.3	
e. Environmental compliance	\$6.8	\$15.6	\$40.9	\$133.7	d
Subtotal all general	\$25.6	\$47.9	\$115.3	\$362.9	
B. Construction					
1. Earthwork					
a. Earthwork, levee construction	\$26.2	\$75.5	\$149.4	\$297.2	e, f
b. Earthwork, coring	\$21.3	\$61.3	\$121.3	\$241.3	e
c. Weirs	\$2.7	\$2.7	\$5.4	\$5.4	g, h, i
d. Boardwalks	\$4.3	\$4.3	\$8.7	\$8.7	e, j, k
Subtotal	\$69	\$294	\$909	\$3,094	
2. Process, conveyance, and controls					
a. Pumps and piping	\$6.9	\$61.2	\$243.8	\$973.6	j, l
b. Chemical dosing system	\$1.7	\$15.1	\$60.1	\$240.2	m, n
c. Power	\$30.0	\$30.0	\$30.0	\$30.0	
d. Controls and monitoring	\$118.0	\$118.0	\$118.0	\$118.0	o
e. Field safety equipment	\$1.0	\$1.0	\$1.0	\$1.0	p
Subtotal	\$157.6	\$225.2	\$453.0	\$1,362.8	
Construction total	\$226.3	\$519.6	\$1,362.3	\$4,457.2	
Subtotal direct capital costs	\$251.9	\$567.5	\$1,477.5	\$4,820.1	
Contingency	25%	25%	25%	25%	
Total direct capital costs	\$315	\$709	\$1,847	\$6,025	
Indirect capital costs					
A. Engineering	\$80.7	\$114.6	\$206.8	\$534.6	q
B. Project management	\$37.8	\$85.1	\$221.6	\$723.0	r
C. Legal and administrative	\$2.5	\$5.7	\$14.8	\$48.2	k
Subtotal indirect capital costs	\$121.0	\$205.4	\$443.2	\$1,305.8	
Total direct and indirect capital costs	\$436	\$915	\$2,290	\$7,331	
Land purchases	\$78	\$512	\$1,914	\$7,417	s
Annual operating and maintenance (O&M) costs					
A. Ponds and wetlands	\$66.1	\$82.0	\$144.9	\$291.4	
B. Chemical system maintenance	\$40.1	\$40.8	\$50.2	\$66.3	
C. System monitoring	\$39.7	\$39.7	\$39.7	\$39.7	
D. Reporting	\$14.2	\$14.2	\$14.2	\$14.2	
Total annual costs	\$160	\$176.7	\$248.9	\$411.5	t, u, v, w

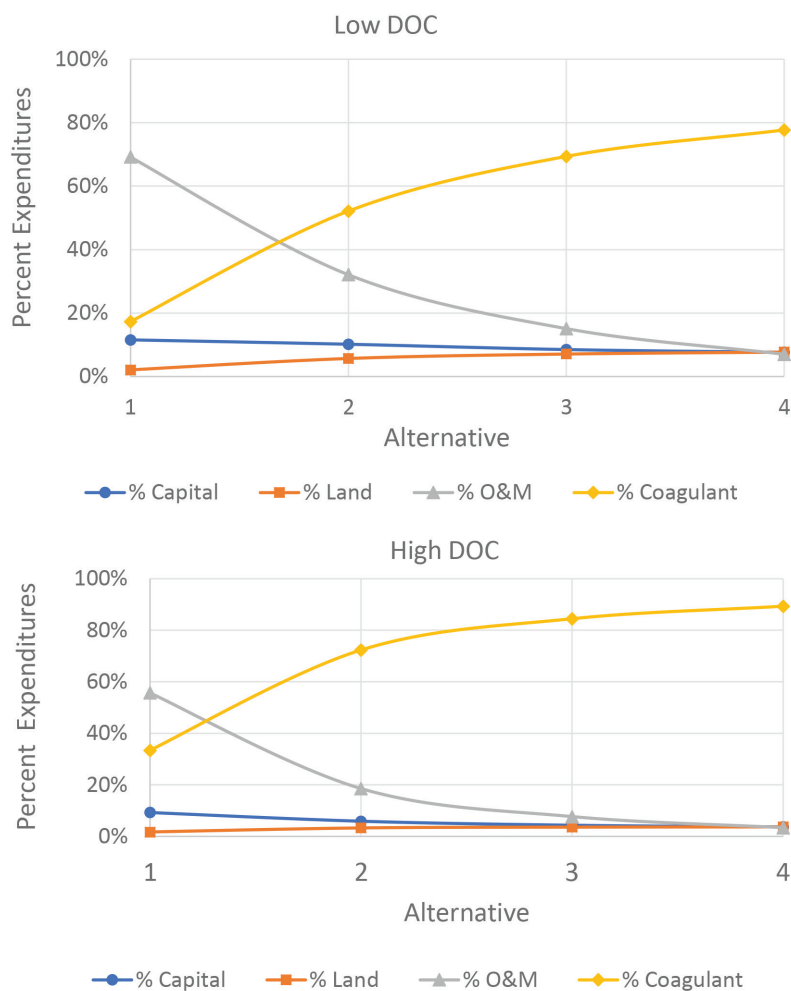

Figure 4 Distribution of percent expenditures over a 20-year period for Chemically Enhanced Treatment Wetland (CETW) sizing alternatives based on low-dissolved organic carbon (DOC) concentrations (*top*) and high-DOC concentrations (*bottom*). Alternatives indicate CETW sizes, with the smallest being Alternative 1, and the largest Alternative 4. Additional details on the design aspects of each alternative are in [Table 1](#).

Table 2 footnotes:

- a. Assume 5% of construction costs.
- b. Assume 1% of construction costs, with \$3,500 minimum (2-man crew for 3 days [LSC 2018]).
- c. Calculated at 1% of construction costs based on Misnan et al. 2012.
- d. Calculated at 3% of construction costs based on NASA 2015.
- e. From LICD study cost history.
- f. Initial (not cored) construction cost distributed 15% for wetland bed grading and 85% for levee construction.
- g. From LICD study and other quotes provided by Polyriser and Pipe.
- h. Number of weirs based upon design flows shown for 36 weir, Cameron Hydraulic Data.
- i. Assume 24 feet of boardwalk required per inflow and outflow structure. For each outflow station, assume one inflow station.
- j. Based upon estimates from Provost and Pritchard for McMullin and for Montezuma cost estimates corrected to 2017 dollars.
- k. Assumed 1% of construction cost.
- l. Assume 50% for additional water delivery piping based upon experience with LICD study.
- m. LICD requires no chemical treatment plant or associated equipment (e.g., concrete tanks, clarifier plates, etc). Mixers may be required and costs are included.
- n. Chemical dosing system costs based upon estimate by CRA (2000), \$1,500 mgd⁻¹. Doubled cost to account for mixers and increased to account for 2017 prices (\$4,958 mgd⁻¹).
- o. Includes hardware, design and installation. Based on LICD system.
- p. Eye wash and other safety equipment.
- q. Calculated based on 15% of earthwork cost (USEPA 2000) plus dosing system engineering costs estimated based on LICD study cost history.
- r. 15% of capital costs (ICF International et al. 2008).
- s. Based on 75th quartile of Delta farms on sale, May 2017.
- t. Assumed 20-year repair cycle at cost to build levee initially.
- u. Includes routine maintenance of pipes, pumps, instrumentation and chemical system, and miscellaneous supplies.
- v. Includes water management and control, vegetation management, mosquito control, levee maintenance, supplies, and fuel.
- w. Costs based upon estimated labor hours.

Table 3 Present value and total annualized cost for alternatives presented in Table 1. Amounts are presented in U.S. dollars. Refer to Table 1 for details on alternatives.

Estimated quantity	Alternatives			
	1	2	3	4
Capital costs				
Direct and indirect costs ^a	\$435,867	\$914,765	\$2,290,133	\$7,330,927
Land	\$77,522	\$512,117	\$1,913,886	\$7,416,978
Total capital cost	\$513,389	\$1,426,882	\$4,204,019	\$14,747,905
Annualized direct and indirect costs	\$26,656	\$55,944	\$140,057	\$448,335
Annualized land cost	\$4,741	\$31,319	\$117,047	\$453,598
Total annualized capital cost	\$31,397	\$87,263	\$257,104	\$901,933
Low DOC removal^b				
Annual costs				
O&M, monitoring	\$160,039	\$176,657	\$248,895	\$411,483
Coagulant purchase	\$39,951	\$287,061	\$1,144,429	\$4,570,097
Total	\$199,990	\$463,718	\$1,393,324	\$4,981,580
Annual treatment				
DOC removed (kgDOC yr ⁻¹)	3,321	29,497	117,597	469,604
Water treated (ac-ft yr ⁻¹)	385	3,416	13,620	54,388
Present value (PV)^c				
PV (20-yr)	\$3,783,512	\$9,009,342	\$26,986,863	\$96,203,872
PV per DOC removed (\$ kgDOC ⁻¹)	\$56.96	\$15.27	\$11.47	\$10.24
Total annualized cost (TAC)^c				
TAC	\$231,387	\$550,982	\$1,650,428	\$5,883,513
TAC per ac-ft	\$602	\$161	\$121	\$108
TAC per DOC removed (\$ kgDOC ⁻¹)	\$69.67	\$18.68	\$14.03	\$12.53
High DOC removal^d				
Annual costs				
O&M, monitoring	\$160,039	\$176,657	\$248,895	\$411,483
Coagulant purchase	\$95,882	\$688,947	\$2,746,629	\$10,968,233
Total	\$255,921	\$865,604	\$2,995,524	\$11,379,715
Annual treatment				
DOC removed (kgDOC)	7,971	70,793	282,232	1,127,050
Water treated (ac-ft)	385	3,416	13,620	54,388
Present value (PV)				
Present value (20-yr)	\$4,698,066	\$15,580,752	\$53,185,136	\$200,822,564
PV per DOC removed (\$ kgDOC ⁻¹)	\$29.47	\$11.00	\$9.42	\$8.91
Total annualized cost (TAC)^c				
TAC	\$287,318	\$952,868	\$3,252,628	\$12,281,649
TAC per ac-ft	\$747	\$279	\$239	\$226
TAC per DOC removed (\$ kgDOC ⁻¹)	\$36.04	\$13.46	\$11.52	\$10.90

a. Not including land.

b. Low DOC, or likely summer DOC levels at 10 mgC L⁻¹. Dosing to achieve 70% removal.

c. Present value and total annualized cost calculated for 20 years with 2% net interest.

d. High DOC, or likely winter DOC levels at 24 mgC L⁻¹. Dosing to achieve 70% removal

Table 4 Cost of polyaluminum chloride (PAC) coagulant use by scenarios (low-dissolved organic carbon [DOC] 10 mg L⁻¹ and high DOC 24 mg L⁻¹). Refer to Table 1 for details on alternatives.

Coagulant scenario	Annual coagulant use by alternative				Units
	1	2	3	4	
Low DOC					
DOC design targets					
Summer DOC levels ^a	10	10	10	10	mg L ⁻¹
Target % DOC removal ^b	70%	70%	70%	70%	%
DOC removed	7	7	7	7	mg L ⁻¹
DOC after dosing	3	3	3	3	mg L ⁻¹
DOC load removal	9	81	322	1,287	kgC d ⁻¹
	3,321	29,497	117,597	469,604	kgC yr ⁻¹
Coagulation requirements					
gDOC removed per gAl ^b	0.95	0.95	0.95	0.95	gDOC gAl ⁻¹
Al required	10	85	339	1354	kgAl d ⁻¹
Al concentration in coagulant	0.166	0.166	0.166	0.166	kgAl L ⁻¹
	58	512	2,041	8,151	L d ⁻¹
	28,190	250,359	998,106	3,985,781	kg yr ⁻¹
Coagulant needed	39,951	287,061	1,144,429	4,570,097	\$ yr ⁻¹
	5,558	49,365	196,804	785,905	gal yr ⁻¹
Cost per kg ^c	1.42	1.15	1.15	1.15	\$ kg ⁻¹
Total costs	\$39,951	\$287,061	\$1,144,429	\$4,570,097	\$ yr ⁻¹
High DOC					
DOC design targets					
Winter DOC levels ^a	24	24	24	24	mg L ⁻¹
Target % DOC removal ^b	70%	70%	70%	70%	%
DOC removed	17	17	17	17	mg L ⁻¹
DOC after dosing	7	7	7	7	mg L ⁻¹
DOC Load removal	22	194	773	3,088	kgC d ⁻¹
	7,971	70,793	282,232	1,127,050	kgC yr ⁻¹
Coagulant needed per wetland					
gDOC removed per gAl ^b	0.95	0.95	0.95	0.95	gDOC gAl ⁻¹
Al required	23	204	814	3250	kgAl d ⁻¹
Al concentration in coagulant	0.166	0.166	0.166	0.166	kgAl L ⁻¹
	138	1,229	4,899	19,561	L d ⁻¹
	67,655	600,861	2,395,455	9,565,876	kg yr ⁻¹
Coagulant needed	95,882	688,947	2,746,629	10,968,233	\$ yr ⁻¹
	13,340	118,476	472,329	1,886,172	gal yr ⁻¹
Cost per kg ^c	1.42	1.15	1.15	1.15	\$ kg ⁻¹
Total costs	\$95,882	\$688,947	\$2,746,629	\$10,968,233	\$ yr ⁻¹

a. Based on data fall 2012 through summer 2013. High and low values reflect differences during seasons.

b. From study results.

c. For Alternate 1, we assumed that coagulant would be purchased in totes (20 to 50 per year for low-high DOC scenarios) and in other alternatives, we assumed bulk coagulant purchase.

costs with costs from Chen et al. (2008) for 7 to 76 mgd (9,400 to 100,000 ac-ft yr⁻¹) treatment plants, which are similar in size to Alternatives 3–4 (See “water treated,” Table 3).

SUMMARY OF DELTA CETW AND OTHER RELEVANT RESULTS

WQCC removal: DOC, DBPPs, Nutrients, and Hg

CETWs removed WQCCs via two steps: coagulation (step 1) and passage of treated water through treatment wetlands to allow particulate settling (step 2). During the coagulation step, coagulant dosing was operated to achieve 65% to 80% DOC removal. For both the Fe and Al treatments, the coagulation step, on average, achieved over 70% DOC removal (Hansen et al. 2018; Bachand et al. 2019a, 2019c). However, passage of treated water through the wetlands reversed some of the removal by coagulation and increased DOC and DBPP levels (both concentration and annual loads) at the outflow relative to post-dose levels. This wetland effect was more pronounced during the warm summer months when DOC production in the wetlands is greater. Despite this, water exiting the coagulant treated wetlands had lower DOC and DBPP levels relative to untreated source water and control treatment outflow water. CETWs removed more DOC and DBPPs during winter months when inflow water DOC concentration was higher and wetland DOC production was lower (Hansen et al. 2018; Bachand et al. 2019c).

Overall, the Al CETWs removed 58% of source water DOC loads (~349 gDOC m⁻²yr⁻¹) and the Fe CETWs removed 41% (~245 gDOC m⁻²yr⁻¹), whereas the control wetlands produced 51 gDOC m⁻²yr⁻¹ (an 8% increase in DOC relative to the source water). DBPP load removals were an order of magnitude lower than DOC removal, with HAA precursors more effectively removed than THM precursors (Hansen et al. 2018; Bachand et al. 2019c). CETWs also consistently removed other WQCCs such as phosphate, DON, DFe, DA1, FTHg, and FMeHg at removal rates of 42% to 93% of source water loads (Stumpner et al. 2015; Bachand et al. 2019b, 2019c).

Subsidence Mitigation

CETWs demonstrated greater sediment and carbon accretion than control wetlands (Stumpner et al. 2018). Al CETWs had the highest vertical accretion rates (~6 cm yr⁻¹) that were distributed consistently throughout the entire wetland. Fe CETWs had similar accretion rates near the wetland inflows (~6 cm yr⁻¹) compared to Al CETWs, but we observed lower rates similar to the untreated wetlands near the middle and outflows (~1.5 cm yr⁻¹). The material deposited in the CETWs had bulk densities of 0.04 to 0.10 g cm⁻³, which are lower than native California peat soils (0.2 to 0.3 g cm⁻³) and could consolidate over time. Carbon burial rates in the Al CETWs were over 2-fold greater than in the control wetlands (Stumpner et al. 2018).

Toxicity and Ecosystem Effects

Observation of established *Typha* plants showed no negative effect on plant growth compared to the control, when plants were exposed continuously to Al- and Fe-floc over two growth seasons. Additionally, no signs of plant toxicity were observed in the controls or coagulant treatments (Liang et al. 2019). However, other similar studies have found that exposure of submerged aquatic vegetation to Al-flocs over a 3-month period caused higher Al accumulation in plant material (Malecki-Brown et al. 2010). Therefore, aquatic plant toxicity may vary with species, and further studies that encompass a wider range of wetland plants are needed. In a related Delta study on the effects of mosquitofish that resided in CETWs and control wetlands, total Hg concentrations were found to be significantly lower (approximately 35%) in mosquitofish in the Fe CETWs compared to those residing in the control wetlands, while mosquitofish in Al CETWs had similar levels of total Hg compared to the control (Ackerman et al. 2015). This may be related to the lower levels of methylmercury (from either suppressed production or additional sequestration) observed in the Fe treatment (Ackerman et al. 2015; Bachand et al. 2019b). Other studies have found that in Al-treated wetlands, there were lower levels of microbial activity in the surface of soils compared to controls; this effect was observed after 3-months of floc exposure (Malecki-Brown et al. 2007;

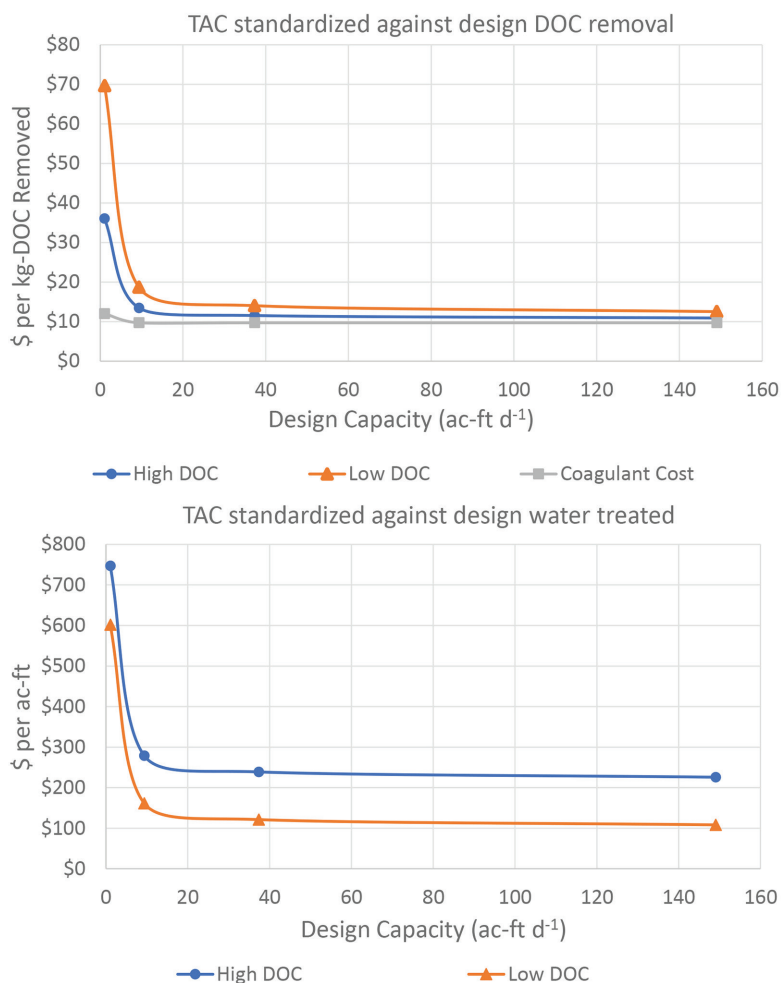

Figure 5 Total annualized cost (TAC) for polyaluminum chloride (PAC) treatment for high and low dissolved organic carbon (DOC) concentrations scenarios standardized per kg DOC removed (*top*) and ac-ft of drainage water treated (*bottom*)

Malecki–Brown and White 2009). Many effects on CETW ecosystems from floc exposure are still unknown, signaling that more comprehensive and longer-term monitoring is needed.

System Design: DOC Surrogates

Both UV254 and FDOM were considered as possible surrogates for DOC concentration and both surrogates required calibration to source water. UV254 was measured in the laboratory (after removal of Fe interference by the addition of hydroxylamine (Doane and Horwath [2010])); FDOM was performed in the field on raw water streams. Results showed that DOC concentration and percent removal correlations were stronger with lab UV254 than with in situ FDOM (Appendix A, Figure A5). Nonetheless, both surrogates were suitable methods for Al-treated water and control source water. Interference by particles and higher Fe levels in the Fe

treatment render FDOM unsuitable as an *in situ* DOC indicator for that treatment. However, for the Fe treatment, we found that pH reliably indicated dosing rates. Field tests indicated that pH decreases of 7% to 10% consistently resulted in DOC removal of 65% to 85% (Bachand et al. 2019a). *In situ* FDOM and pH measurements on source water allow real-time determination of dosing requirements, making the system amenable to automation. Although laboratory methods are typically more accurate than real-time methods, a larger time delay is needed to obtain results with the former, potentially making laboratory methods unsuitable for systems that treat source waters with rapidly changing properties. Control systems—comprised of regularly programmed measuring devices, programming devices, and automated dosing that follows rule-based calculations of dosing goals and requirements—can vary in complexity and

may not require complete automation to meet the needs of all CETWs. In this study, because DOC concentrations in drain water were relatively stable on a seasonal basis, manual adjustments of dosing rates with set flow rates and occasional checks of in situ measurements against laboratory analyses provided reasonable performance with a simple, non-automated system (Bachand et al. 2019a).

COST RESULTS: COST BY ALTERNATIVE

The four design alternatives included in this study spanned a range of proposed wetland sizes (3 to 400 acres; Table 1) and treatment capacities (1 to 149 ac-ft d⁻¹; Table 1). For the smallest CETW alternative—Alternative 1—characterized by a 3-ac wetland, total direct and indirect capital costs would be approximately \$436K, land purchases are estimated at approximately \$78K, and annual O&M costs, excluding coagulant use, are estimated at approximately \$160K (Table 2). For the largest CETW alternative—Alternative 4—characterized by a 400-ac wetland (with over two-orders-of-magnitude greater treatment capacity than the smaller CETW), total direct and indirect capital costs would be approximately sixteen times greater at \$7.3M, land purchases are two orders of magnitude higher at \$7.4M, and annual O&M costs are approximately two times higher at \$411K (Table 2). Cost distributions over a 20-year period show that for smaller CETWs (Alternative 1), the majority of costs reside in O&M for these systems (70%, Figure 4). As the design alternative size increases, the percentage of expenditures used for O&M and capital costs decreases, and the percentage of expenditures used for coagulant purchases increases, making coagulant purchase the main cost associated with larger CETWs (50% to 80%, Alternatives 2-4, Figure 4).

We based coagulant costs per alternative on the use of PAC (Al treatment), because of its better DOC and DBPP removal and floc stability (Liang 2016; Bachand et al. 2019c), as well as lower Hg content, as compared to ferric sulfate (Fe treatment) (Bachand et al. 2019b). We estimated coagulant costs for two different DOC levels; high DOC (24 mg L⁻¹) and low DOC (10 mg L⁻¹), based on

observed source water DOC concentrations that entered study control wetlands during fall/winter and summer/spring, respectively (Appendix A, Figure A6). We assumed a DOC removal efficiency of 70%, based on study findings (Hansen et al. 2018; Bachand et al. 2019a, 2019c). Using the aforementioned assumptions, and to treat low-DOC source waters, approximately 28Kkg yr⁻¹ of PAC are needed for Alternative 1 and 4Mkg yr⁻¹ of PAC for Alternative 4, with estimated annual costs of \$40K and \$4.6M, respectively (Table 4). For high-DOC scenarios, more coagulant is required, and thus coagulant costs increase by a factor of 2.4. DOC levels in Delta island drains will vary throughout the year, as we observed at our field site, so coagulant costs are likely to be between the high and low DOC scenarios.

TAC estimates show that under low-DOC scenarios (Table 3), Alternative 1 CETW costs are \$70 per kgDOC removed, and \$602 per ac-ft of water treated. Under Alternative 4, these costs are lower due to economies of scale, costing \$12.5 per kgDOC removed, and \$108 per ac-ft treated. Under high-DOC scenarios, costs reflect greater coagulant demand; under Alternative 1, CETW costs are \$36 per kgDOC removed, and \$747 per ac-ft of water treated. However, again, with increased size in Alternative 4, costs decrease to \$11 per kgDOC removed, and \$226 per ac-ft treated. For both high- and low-DOC scenarios, economies of scale become evident at approximately 15 ac-ft d⁻¹ design capacity (Figure 5). At and above 20 ac-ft d⁻¹ design capacity, treatment costs for both high- and low-DOC scenarios are below \$15 per kgDOC removed, and are relatively flat with increasing design capacity, with low-DOC scenarios resulting in slightly higher TAC than high-DOC scenarios. Economies of scale are also evident when costs are viewed in terms of TACs per ac-ft water treated (Figure 5), but these costs are greater for the high-DOC scenario than for the low-DOC scenario.

DISCUSSION

Control and Simplification

CETWs in the Delta can be designed and simplified to fit specific needs. As mentioned

earlier, use of FDOM and pH sensors—by developing curves to predict DOC and corresponding coagulant dosing requirements—can facilitate the use of automated dosing. Advantages of an automated measurement and dosing system are more flexibility, quick adaptation to changing circumstances, and easier adjustment and monitoring; this allows for greater efficiency but, noted here in this and other studies, automation may not be appropriate or economical in all CETWs. In situations with very predictable inputs and treatment goals, manual dosing adjustments that use occasional laboratory DOC measurements may be the most cost-effective way to operate the coagulation system.

Cost Comparison with other Treatment Technologies

DOC is a drinking water concern because it reacts with chlorine to produce DBPs (HAAs and THMs), and thus its removal before drinking water disinfection is important. Standard disinfection technologies such as ozonation and UV radiation may reduce the formation of DBPs. Ozonation is one of the most commonly used technologies for disinfecting Delta water, and although it does not produce THMs or HAAs, it does produce bromate in the presence of bromide, which is commonly found in Delta waters (Chow et al. 2003; Richardson et al. 2003; Chen et al. 2008). Depressing pH can control bromate formation, but lower pH can increase the cost of ozonation. Estimated TAC for adding ozonation to an existing treatment plant is approximately \$90–\$200 per ac-ft (Chen et al. 2008; Chen et al. 2010). UV, which is not as commonly used to treat Delta water, can disinfect water without forming DBPs. But suspended solids must be removed before treatment, otherwise disinfection efficacy is compromised. UV radiation also requires regular lamp cleaning and large amounts of electricity, and it does not provide any residual disinfection. Estimated TAC for adding UV treatment to an existing water treatment plant is \$12–\$27 per ac-ft (Chen et al. 2008; Chen et al. 2010). Poor WQCC removal before disinfection with the aforementioned technologies can increase costs and lower disinfection efficacy, in addition to increasing health risks to consumers because there is a higher potential for DBPs to form.

CETW costs are competitive with the costs of other methods used to remove DOC and DBPPs from Delta waters. These methods include enhanced coagulation, granular activated carbon, microfiltration/ultrafiltration, and nanofiltration. We modified cost estimates for these technologies from Chen et al. (2010) to reflect costs on a carbon-removal basis. Assuming a carbon concentration of approximately 3 mg L⁻¹ (based on a range of 1–5 mg L⁻¹ from Roy et al. [2006]) and 75% removal, enhanced coagulation TAC standardized to carbon removal is \$9–\$11 per kg-C, slightly lower than CETW costs of \$11 to \$14 per kgDOC. Other technologies have higher costs than CETWs: granular activated carbon (\$29 to \$33 per kgC); microfiltration/ultrafiltration (\$101 to \$142 per kgC); and nanofiltration (\$171 to \$218 per kgC).

Main Costs and Cost Saving Opportunities

Potential opportunities for CETW cost savings include increasing settling rates to allow lower HRTs. Floc aggregation characteristics and settling rates have been shown to vary with different coagulants treating the same source water (Bachand et al. 2006). Settling rates 4 to 20 times greater have been observed for aluminum-based coagulants compared to untreated water (Bachand et al. 2006). Additional cost savings are also possible if the coagulation process is further improved with the addition of polyacrylamides or other coagulant aids, which typically costs less than metal-based coagulants and improve settling rates and removal efficiencies (Bachand et al. 2000). With a lower HRT, a given system can treat more water or require less space while maintaining the same costs associated with capital equipment, land, and O&M; and cost standardized to DOC removal drops with lower HRT because of more efficient equipment and land use (Figure 6). As an example, Alternative 3, with a 100-acre wetland, is designed to treat runoff from 3,600 acres with a 4-day HRT. If the same wetland acreage is used with a 1-day HRT, the treatable area is four times larger (~14,400 acres). By decreasing the HRT from 4 days to 1 day, the wetland area drops from 2.8% to 0.7% of treated area. TAC increases as a result of greater coagulant use, but TAC per kg carbon removed drops from \$11.5 to \$12.2 per kgDOC for

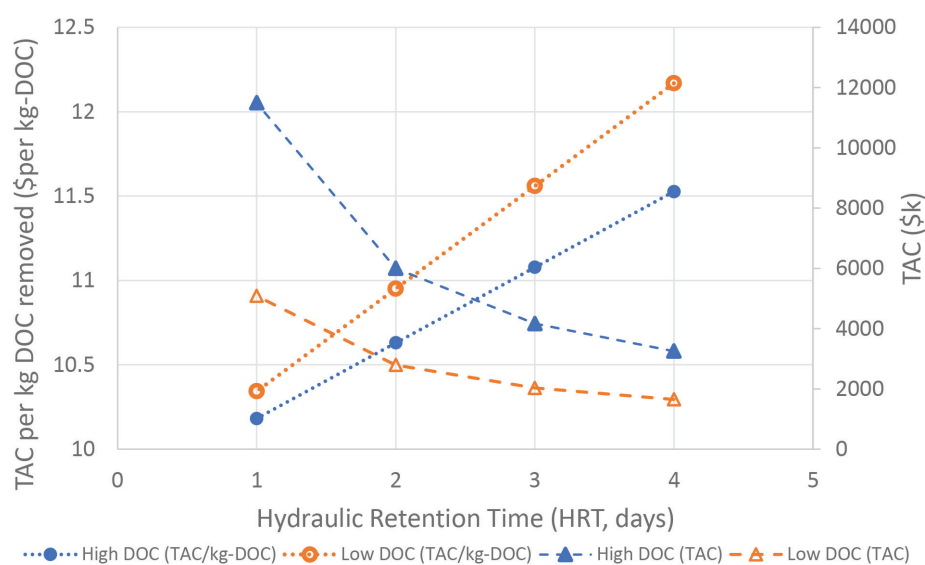

Figure 6 Total annualized cost (TAC) estimates with varying hydraulic retention times (HRTs) for low- and high-dissolved organic carbon (DOC) scenarios

a 4-day HRT to \$10.2 to \$10.3 per kgDOC for a 1-day HRT (Figure 6).

Another way to lower CETW costs is to reduce treatment design flow rates by maintaining a steady flow of incoming water to be treated, rather than large spikes in incoming water flows, which necessitate more contingency in the design treatment capacity that is not required throughout the year. As discussed in the “Design and Cost Analyses” section, the treatable island area was based upon discharge flow rates from Twitchell Island using the 75th percentile flow rate (Figure 3). Arguments can be made for reducing that flow rate by creating water storage for excess water in need of treatment (Bachand et al. 2010). At Twitchell Island and throughout the Delta system, areas have been identified that cannot be farmed because they have become permanently flooded (Deverel et al. 2015); these areas may be well suited for water storage with minimal modifications, barring water-delivery infrastructure needed for transport to CETWs. Other island practices may also be used to reduce needed treatment design flow rates, such as strategic placement of rice fields and wetlands on Delta islands to reduce levee failure risks (Deverel et al. 2016a, 2016b; Bachand et al., manuscript in preparation). Bachand et al. (manuscript in preparation) suggest that converting the status quo to rice fields can reduce seepage infiltration onto islands from surrounding waters, and reduce

off-island pumping. These strategies for increasing island sustainability will also reduce spikes in water flow rates that need treatment so treatment design flow rates can be reduced from the 75th to the 50th percentile of historic pump flow rates (Figure 3). For Twitchell Island, this corresponds to decreasing the design flow rate from 36.5 ac-ft d⁻¹ to approximately 22.7 ac-ft d⁻¹. The potential treatable area of the wetland system increases by 60%, reducing the size of the CETW system from 2.8% to 1.7% of total treated area.

Estimated Treatment Costs for Implementation throughout the Delta

Overall, CETWs offers an economically competitive treatment option compared to already established full-scale water treatment plants, even with the addition of costs not considered in already established treatment plants (i.e., infrastructure cost, engineering, maintenance, labor, materials). In the future, largely as a result of rising sea levels, water treatment costs are expected to increase as water quality worsens from higher salt and bromide content (Chen et al. 2008). Water treatment costs are also likely to increase for WQCCs, because higher infiltration from surrounding waters is expected to mobilize more constituents. Many of the current water treatment facilities in the Delta have a capacity similar to the larger CETW alternatives presented here (37–149 ac-ft d⁻¹). Only water treatment facilities associated with the South Bay pumps that convey

water to Southern California have larger capacities (Chen et al. 2008). Although CETWs are not designed with treatment objectives identical to traditional water treatment plants, the comparison is relevant because, where their objectives do overlap, CETWs can be cost competitive while providing additional benefits to the Delta as a whole and to individual islands. Besides providing wetland wildlife habitat, CETWs help mitigate land subsidence and remove Hg, two primary issues in the Delta (Ackerman et al. 2015; Deverel et al. 2016b). Hg is an environmental and public health issue regulated under a MeHg total maximum daily load (TMDL) promulgated by the Central Valley Regional Water Quality Control Board (2011), in which CETWs could play an important compliance role (McCord and Heim 2015).

Using relationships developed in this study, we estimated treatment costs for islands throughout the Delta (Appendix A, Table A6). Most islands reached similar costs from converging economies of scale, except islands that have small areas (<2,500 acres). For low-DOC scenarios, most islands fell into a range of \$10 to \$23 per kgDOC removed, and \$87 to \$200 per ac-ft treated; for high-DOC scenarios, those values changed to \$9 to \$16 per kgDOC removed, and \$190 to \$350 per ac-ft treated. A main driver of the costs is likely to be the quality of the source water, which will determine the necessary dosage of coagulant. Given the Delta's problems with DOC, Hg, and land subsidence, CETWs are well suited to combat these issues for many existing subsided islands, and they require only 3% (or less) of the total area being treated, leaving the remaining land area for agriculture or habitat. Based on information presented here, CETWs are multi-functional when implemented on Delta islands; they are scalable, cost-effective, resilient and reliable. Site-specific attributes will determine the efficacy and investment success for CETWs; including, but not limited to, source water quality and predictability, land availability, energy needs, infrastructural protection needs and costs.

CONCLUSIONS

The Delta presents many challenges for California water managers. While management of water supplies through the Delta is an important and politically engaging issue, other critical challenges to the well-being of the Delta include water quality degradation, land subsidence, sea level rise, loss of agricultural productivity, and contamination of natural ecosystems. WQCCs including DOC, DBPP, phosphate and Hg all pose risks to the Delta ecosystem and its beneficial uses. The viability of the Delta as a continuing water conveyance component, critical to California's water management, is dependent upon water quality protection and levee stability. CETWs are uniquely suited to address these two problems for Delta island managers and may become critical in helping some islands meet regulatory standards including MeHg TMDLs. A series of studies have demonstrated that CETWs can effectively treat agricultural drainage water for DOC, DBPP, phosphates, DON, metals, and Hg species. CETWs also counteract land subsidence, which occurs in peaty areas oxidized by status quo agricultural practices on Delta islands. As a non-traditional form of water treatment, CETWs can remove WQCCs with fewer infrastructural expenses compared with traditional water treatment plants, in addition to accelerating soil accretion rates and avoiding expenses associated with floc removal. CETWs compare competitively with existing water treatment plants and other DOC treatment methods in costs per unit DOC removed. While CETWs require non-trivial investment for implementation, operation and maintenance, the overall system costs will vary widely depending on source water inputs, design capabilities, WQCC reduction targets, and available land. CETW long-term costs are heavily impacted by chemical usage which is determined by source water quality. Cost-savings through more efficient dosing design such as addition of coagulant aids to hasten floc settling and reduce required HRT, is expected to decrease expenditures associated with treatment. Similarly, treatment design flow rates may be decreased

through the use of strategic water storage areas on the island (where infrastructural costs of transporting from storage area to CETWs are not prohibitive) which can decrease the amount of land dedicated to CETWs.

ACKNOWLEDGEMENTS

We are grateful for funds provided by the California Department of Water Resources (Agreement 46000003886/7W4CA4000003886), U.S. Environmental Protection Agency (Agreement DW1495825700) and matching funds provided by the USGS Cooperative Water Program. We would like to acknowledge Timothy A. Doane for his lab support; Fred Simms for providing expertise on coagulants; Brett Offerman for logistical help; DWR for providing the field site; Jim Casey and Bruce Gornto for field assistance and management; Marc Estrade, Jeff Schuyler and Eyasco for help with the electronic system in the field; Elizabeth Stumpner, Jacob Fleck, Angela Hansen, Yan Liang, and Dylan Stern for their support during this study; Stephen McCord for reviewing this manuscript; Robert Pedlar and Genevieve Schrader for their exemplary efforts to support and advise on this project and lastly, we greatly appreciate Dr. Roger Fujii of the USGS who supported Dr. Bachand through co-writing of proposals, and the immense implementation and project team efforts provided. Any use of trade, firm, or product names is for descriptive purposes only and does not imply endorsement by the U.S. Government.

REFERENCES

- Ackerman JT, Eagles-Smith CA, Heinz G, De La Cruz SE, Takekawa JY, Miles AK, Adelsbach TL, Herzog MP, Bluso-Demers JD, Demers SA, Herring G. 2014. Mercury in birds of San Francisco Bay-Delta, California: trophic pathways, bioaccumulation, and ecotoxicological risk to avian reproduction. US Geological Survey. Open-File Report 2014-1251 [accessed 2019 July 10];202 p. <https://doi.org/10.3133/ofr20141251>
- Ackerman JT, Kraus TE, Fleck JA, Krabbenhoft DP, Horwath WR, Bachand SM, Herzog MP, Hartman CA, Bachand PA. 2015. Experimental dosing of wetlands with coagulants removes mercury from surface water and decreases mercury bioaccumulation in fish. *Environ Sci Technol*. [accessed 2019 July 10];49:6304–6311. <https://doi.org/10.1021/acs.est.5b00655>
- Aguilar M, Saez J, Llorens M, Soler A, Ortuno J. 2002. Nutrient removal and sludge production in the coagulation–flocculation process. *Water Res*. [accessed 2019 July 10];36:2910–2919. [https://doi.org/10.1016/S0043-1354\(01\)00508-5](https://doi.org/10.1016/S0043-1354(01)00508-5)
- Akbal F, Camcı S. 2010. Comparison of electrocoagulation and chemical coagulation for heavy metal removal. *Chem Eng Technol*. [accessed 2019 July 10];33:1655–1664. <https://doi.org/10.1002/ceat.201000091>
- Bachand PAM, Bachand SM, Kraus TEC, Stumpner EB, Stern D, Liang YL, Horwath WR. 2019b. Mercury sequestration and transformation in chemically enhanced treatment wetlands. *Chemosphere*. [accessed 2019 July 10];217:496–506. <https://doi.org/10.1016/j.chemosphere.2018.10.144>
- Bachand PAM, Bachand SM, Kraus TEC, Stern D, Liang YL, Horwath WR. 2019c. Sequestration and transformation in chemically enhanced treatment wetlands: DOC, DBPPs and Nutrients. *J Env Eng*. [accessed 2019 July 10];145(8):04019044. <https://ascelibrary.org/doi/full/10.1061/%28ASCE%29EE.1943-7870.0001536>
- Bachand PAM, Bachand SM, Lopus S, Heyvaert A, Werner I. 2010a. Treatment with chemical coagulants at different dosing levels changes ecotoxicity of stormwater from the Tahoe basin, California, USA. *J Environ Sci Health A*. [accessed 2019 July 10];45:137–154. <https://doi.org/10.1080/10934520903425459>
- Bachand PAM, Bachand SM, Stern D, Deverel S, Horwath WR. 2018. Rice drain management to reduce seepage exports in the Sacramento–San Joaquin Delta, California. *J Environ Qual*. [accessed 2019 July 10];47:1186–1195. Available from: <https://dl.sciencesocieties.org/publications/jeq/abstracts/47/5/1186>

- Bachand PAM, Heyvaert A, Prentice S, Delaney T. 2010b. Feasibility study and conceptual design for using coagulants to treat runoff in the Tahoe Basin. *J Env Eng.* [accessed 2019 July 10];136:1218–1230. Available from: [https://ascelibrary.org/doi/abs/10.1061/\(ASCE\)EE.1943-7870.0000261](https://ascelibrary.org/doi/abs/10.1061/(ASCE)EE.1943-7870.0000261)
- Bachand PAM, Heyvaert A, Werner I, Bachand SM. 2007. Chemical treatment methods pilot (CTMP) system for treatment of urban runoff–phase I. Feasibility and design. Bachand & Associates, UC Davis, Desert Research Institute. Final report for the City of South Lake Tahoe. [accessed 2019 July 10];120 p. Available from: http://aquaticcommons.org/1875/1/CTMP_Phase_I_Final_with_Appendices_22Feb07.pdf
- Bachand PAM, Trejo–Gaytan J, Darby J, Reuter J. 2006. Small-scale studies on low intensity chemical dosing (LICD) for treatment of highway runoff. Bachand & Associates, UC Davis. Final report. [accessed 2019 July 10];110 p. Available from: <http://citeseerx.ist.psu.edu/viewdoc/download?doi=10.1.1.640.1444&rep=rep1&type=pdf>
- Bachand PAM, Vaithyanathan P, Richardson C. 2000. Phase II low intensity chemical dosing (LICD): development of management practices. Duke University Wetland Center, Florida Department of Environmental Protection. Final report submitted to Florida Department of Environmental Protection in fulfillment of Contract No. WM720. [accessed 2019 July 10]; 227 p. Available from: http://aquaticcommons.org/1876/1/Phase_2_LICD_Final_Report.pdf
- Bachand SM, Kraus TEC, Stern D, Liang YL, Horwath WR, Bachand PAM. 2019a. Aluminum- and iron-based coagulation for *in-situ* removal of dissolved organic carbon, disinfection byproducts, mercury and other constituents from agricultural drain water. *Ecol Eng.* [accessed 2019 July 10];134:26–38. <https://doi.org/10.1016/j.ecoleng.2019.02.015>
- Berger BB. 1987. Control of organic substances in water and waste water. Norwich (NY): William Andrew Publishing.
- Bratby J. 2006. Coagulation and flocculation in water and wastewater treatment. [London]: IWA Publishing; 2nd edition.
- Chen W–H, Haunschild K, Lund JR. 2008. Delta drinking water quality and treatment costs technical appendix H. Public Policy Institute of California Report, University of California, Davis. Report Technical Appendix. [accessed 2019 July 10];40 p. Available from: https://www.ppic.org/content/pubs/other/708EHR_appendixH.pdf
- Chen W–H, Haunschild K, Lund JR, Fleenor WE. 2010. Current and long-term effects of Delta water quality on drinking water treatment costs from disinfection byproduct formation. *San Franc Estuary Watershed Sci.* [accessed 2019 July 10];8. <https://doi.org/10.15447/sfews.2010v8iss3art4>
- Chow AT, Tanji KK, Gao S. 2003. Production of dissolved organic carbon (DOC) and trihalomethane (THM) precursor from peat soils. *Water Res.* [accessed 2019 July 10];37:4475–4485. [https://doi.org/10.1016/S0043-1354\(03\)00437-8](https://doi.org/10.1016/S0043-1354(03)00437-8)
- [CRA] Conestoga–Rovers & Associates. 2000. Chemical treatment followed by solids separation advanced technology demonstration project. HSA Engineers & Scientists, Milian, Swain & Associates. South Florida Water Management District. Final report. [accessed 2019 July 10];192 p. Available from: <https://www.sfwmd.gov/sites/default/files/documents/ctss%20final%20report.pdf>
- Croué JP, Lefebvre E, Martin B, Legube B. 1993. Removal of dissolved hydrophobic and hydrophilic organic substances during coagulation/flocculation of surface waters. *Water Sci Technol.* [accessed 2019 July 10];27:143–152. <https://doi.org/10.2166/wst.1993.0273>
- [CVRWQCB] Central Valley Regional Water Quality Control Board. 2011. Amendments to the Water Quality Control Plan for the Sacramento River and San Joaquin River basins for the control of methylmercury and total mercury in the Sacramento–San Joaquin River Delta Estuary. Attachment 1 to Resolution No. R5–2010–0043. California Water Boards; [updated 2019 June 13; accessed 2019 July 10]. Available from: https://www.waterboards.ca.gov/rwqcb5/water_issues/tmdl/central_valley_projects/delta_hg/2011_1020_deltahg_bpa.pdf

- De Parsia ER, Fleck JA, Krabbenhoft DP, Hoang K, Roth D, Randall P. 2019. Coagulant and sorbent efficacy in removing mercury from surface waters in the Cache Creek watershed, California. U.S. Geological Survey, U.S. Environmental Protection Agency. Open-File Report 2019–1001. [accessed 2019 July 10];46 p. Available from: <https://pubs.usgs.gov/of/2019/1001/ofr20191001.pdf>
- Deverel SJ, Bachand SM, Brandenberg SJ, Jones CE, Stewart JP, Zimmaro P. 2016a. Factors and processes affecting Delta levee system vulnerability. *San Franc Estuary Watershed Sci.* [accessed 2019 July 10];14(4). <https://doi.org/10.15447/sfews.2016v14iss4art3>
- Deverel SJ, Ingrum T, Leighton D. 2016b. Present-day oxidative subsidence of organic soils and mitigation in the Sacramento–San Joaquin Delta, California, USA. *Hydrogeol.* [accessed 2019 July 10];24:569–586. Available from: <https://link.springer.com/article/10.1007/s10040-016-1391-1>
- Deverel SJ, Lucero CE, Bachand SM. 2015. Evolution of arability and land use, Sacramento–San Joaquin Delta, California. *San Franc Estuary Watershed Sci.* [accessed 2019 July 10];13(2). <https://doi.org/10.15447/sfews.2015v13iss2art4>
- Deverel SJ, Rojstaczer S. 1996. Subsidence of agricultural lands in the Sacramento–San Joaquin Delta, California: role of aqueous and gaseous carbon fluxes. *Water Resour Res.* [accessed 2019 July 10];32:2359–2367. <https://doi.org/10.1029/96WR01338>
- Doane TA, Horwath WR. 2010. Eliminating interference from iron(III) for ultraviolet absorbance measurements of dissolved organic matter. *Chemosphere.* [accessed 2019 July 10];78(11):1409–1415. <https://doi.org/10.1016/j.chemosphere.2009.12.062>
- El Samrani A, Lartiges B, Villiéras F. 2008. Chemical coagulation of combined sewer overflow: Heavy metal removal and treatment optimization. *Water Res.* [accessed 2019 July 10];42:951–960. <https://doi.org/10.1016/j.watres.2007.09.009>
- Fleck JA, Fram MS and Fujii R. 2007. Organic carbon and disinfection byproduct precursor loads from a constructed, non-tidal wetland in California's Sacramento–San Joaquin Delta. *San Franc Estuary Watershed Sci.* [accessed 2019 July 10];5(2). <https://doi.org/10.15447/sfews.2007v5iss2art1>
- Fujii R, Ranalli AJ, Aiken GR, Bergamaschi BA. 1998. Dissolved organic carbon concentrations and compositions, and trihalomethane formation potentials in waters from agricultural peat soils, Sacramento–San Joaquin Delta, California: implications for drinking-water quality. U.S. Dept. of the Interior, U.S. Geological Survey; Information Services [distributor]. *Water-Resources Investigations Report 98-4147.* [accessed 2019 July 10]. <https://doi.org/10.3133/wri984147>. 75 p.
- Google Earth Pro 7.3, 2017. Twitichell Island 38°05'55.19" N 121°39'19.08" W, elevation -21 ft. Viewed 2018 Sept 6. Google Earth Pro. [accessed 2019 July 10].
- Haberl R, Grego S, Langergraber G, Kadlec RH, Cicalini A–R, Dias SM, Novais JM, Aubert S, Gerth A, Thomas H. 2003. Constructed wetlands for the treatment of organic pollutants. *J Soils Sediments.* [accessed 2019 July 10];3:109. Available from: <https://link.springer.com/article/10.1007/BF02991077>
- Hammer DA. 1989. *Constructed wetlands for wastewater treatment: municipal, industrial and agricultural.* Boca Raton (FL): CRC Press.
- Hansen AM, Kraus TEC, Bachand SM, Horwath WR, Bachand PAM. 2018. Wetlands receiving water treated with coagulants improve water quality by removing dissolved organic carbon and disinfection byproduct precursors. *Sci Total Environ.* [accessed 2019 July 10];622:603–613. <https://doi.org/10.1016/j.scitotenv.2017.11.205>
- Harper H. 1994. Alum treatment of stormwater runoff – Orlando's Lake Dot and Lake Lucerne systems. *Lake Reservoir Manag.* 9(2):81.
- Harper H, Herr J, Livingston E. 1998. Alum treatment of stormwater: the first ten years. *New Appl Model Water Syst.* [accessed 2019 July 10];159–180. Available from: <https://www.chijournal.org/Journals/PDF/R204-09>
- Henneberry YK, Kraus TEC, Krabbenhoft DP, Horwath WR. 2016. Investigating the temporal effects of metal-based coagulants to remove mercury from solution in the presence of dissolved organic matter. *Environ Manag.* [accessed 2019 July 10];57(1):220–228. Available from: <https://link.springer.com/article/10.1007/s00267-015-0601-2>

- Henneberry YK, Kraus TEC, Fleck JA, Krabbenhoft DP, Bachand PAM, Horwath WR. 2011. Removal of inorganic mercury and methylmercury from surface waters following coagulation of dissolved organic matter with metal-based salts. *Sci Total Environ*. [accessed 2019 July 10];409(3):631-637. <https://doi.org/10.1016/j.scitotenv.2010.10.030>
- [ICF et al.] ICF International, Venner Consulting, CH2M Hill, University of Florida. 2008. Guide to estimating environmental costs. American Association of State Highway and Transportation Officials (AASHTO) Standing Committee on the Environment. Report. [accessed 2019 July 10];47 p. Available from: https://environment.transportation.org/pdf/proj_delivery_stream/nchrp25-25task%2039guidance.pdf
- Kraus TEC, Bergamaschi BA, Hernes PJ, Spencer RG, Stepanauskas R, Kendall C, Losee RF, Fujii R. 2008. Assessing the contribution of wetlands and subsided islands to dissolved organic matter and disinfection byproduct precursors in the Sacramento–San Joaquin River Delta: a geochemical approach. *Org Geochem*. [accessed 2019 July 10];39(9):1302-1318. <https://doi.org/10.1016/j.orggeochem.2008.05.012>
- Lee W, Westerhoff P. 2006. Dissolved organic nitrogen removal during water treatment by aluminum sulfate and cationic polymer coagulation. *Water Res*. [accessed 2019 July 10];40:3767-3774. <https://doi.org/10.1016/j.watres.2006.08.008>
- Liang YL, Kraus TEC, Silva LC, Bachand PAM, Bachand SM, Doane TA, Horwath WR. 2019. Effects of ferric sulfate and polyaluminum chloride coagulation enhanced treatment wetlands on Typha growth, soil and water chemistry. *Sci Total Environ*. [accessed 2019 July 10];648:116-124. <https://doi.org/10.1016/j.scitotenv.2018.07.341>
- Liang YL. 2016. Chemical and structural characterization of material formed in constructed wetlands treated with metal based coagulants and their effects on wetland vegetation [dissertation]. Davis (CA): University of California. 133 p. Available from: http://icpms.ucdavis.edu/application/files/8815/3609/6560/Chemical_and_Structural_Charac.pdf
- Lopus S, Bachand PAM, Heyvaert A, Werner I, Teh SJ, Reuter J. 2009. Potential toxicity concerns from chemical coagulation treatment of stormwater in the Tahoe basin, California, USA. *Ecotoxicol Environ Saf*. [accessed 2019 July 10];72:1933-1941. <https://doi.org/10.1016/j.ecoenv.2009.04.004>
- [LSC] Land Surveying Costs. c2018. ProMatcher Cost Report. Land Surveying Costs & Prices. [accessed 2019 July 10]. Available from: <https://land-surveyors.promatcher.com/cost/>
- Luoma SN, Dahm CN, Healey M, Moore JN. 2015. Challenges facing the Sacramento–San Joaquin Delta: complex, chaotic, or simply cantankerous? *San Franc Estuary Watershed Sci*. [accessed 2019 July 10];13(3). <https://doi.org/10.15447/sfews.2015v13iss3art7>
- Lund J, Hanak E, Fleenor W, Bennett W, Howitt R. 2010. Comparing futures for the Sacramento–San Joaquin Delta. Berkeley (CA): UC Press. 219 p.
- Lund JR, Hanak E, Fleenor W, Bennett W, Howitt R, Mount J, Moyle P. 2008. Comparing futures for the Sacramento–San Joaquin Delta. San Francisco (CA): Public Policy Institute of California. [accessed 2019 July 10];147p. Available from: https://www.ppic.org/content/pubs/report/R_708EHR.pdf
- Malecki–Brown LM, White JR. 2009. Effect of aluminum-containing amendments on phosphorus sequestration of wastewater treatment wetland soil. *Soil Sci Soc Am J*. [accessed 2019 July 10];73:852–861. Available from: <https://dl.sciencesocieties.org/publications/sssaj/abstracts/73/3/852>
- Malecki–Brown LM, White JR, Brix H. 2010. Alum application to improve water quality in a municipal wastewater treatment wetland: effects on macrophyte growth and nutrient uptake. *Chemosphere*. [accessed 2019 July 10];79:186–192. <https://doi.org/10.1016/j.chemosphere.2010.02.006>
- Malecki–Brown LM, White JR, Reddy K. 2007. Soil biogeochemical characteristics influenced by alum application in a municipal wastewater treatment wetland. *J Environ Qual*. [accessed 2019 July 10];36:1904–1913. Available from: <https://dl.sciencesocieties.org/publications/jeq/abstracts/36/6/1904>
- McCord SA, Heim WA. 2015. Identification and prioritization of management practices to reduce methylmercury exports from wetlands and irrigated agricultural lands. *Environ Manag*. [accessed 2019 July 10];55(3):725–740. Available from: <https://link.springer.com/article/10.1007/s00267-014-0425-5>
- Medellín–Azuara J, Hanak E, Howitt RE, Fleenor WE, Lund JR. 2014. Agricultural losses from salinity in California's Sacramento San Joaquin Delta. *San Franc Estuary Watershed Sci*. [accessed 2019 July 10];12(1). <https://doi.org/10.15447/sfews.2014v12iss1art3>

- Metcalf L, Eddy H. 2009. Wastewater engineering: treatment, disposal, reuse. New York (NY): McGraw-Hill.
- Misnan MS, Yusof ZM, Mohamed SF, Othman N. 2012. Safety cost in construction projects. The 3rd International Conference on Construction Industry, April 10–11, 2012; Padang, Indonesia.
- Mount J, Twiss R. 2005. Subsidence, sea level rise, and seismicity in the Sacramento–San Joaquin Delta. *San Franc Estuary Watershed Sci.* [accessed 2019 July 10];3(1). <https://doi.org/10.15447/sfew.2005v3iss1art7>
- Murphy DD, Weiland PS, Cummins KW. 2011. A critical assessment of the use of surrogate species in conservation planning in the Sacramento–San Joaquin Delta, California (USA). *Conserv Biol.* [accessed 2019 July 10]; 25(5):873–878. <https://doi.org/10.1111/j.1523-1739.2011.01711.x>
- [NASA] National Aeronautics and Space Administration. 2015. Appendix L: estimating the cost of construction of facilities (CoF) and ground support equipment (GSE). In: NASA. 2015. NASA cost estimating handbook (CEH). Version 4.0. [accessed 2019 July 10]; 15 p. Available from: https://www.nasa.gov/sites/default/files/files/CEH_AppL.pdf
- [PPIC] Public Policy Institute of California. 2016. The Sacramento–San Joaquin Delta. San Francisco (CA): PPIC. [accessed 2019 July 10];4 p. Available from: https://www.ppic.org/content/pubs/report/R_1016JM5R.pdf
- Richardson SD, Thruston AD, Rav–Acha C, Groisman L, Popilevsky I, Juraev O, Glezer V, McKague AB, Plewa MJ, Wagner ED. 2003. Tribromopyrrole, brominated acids, and other disinfection byproducts produced by disinfection of drinking water rich in bromide. *Environ Sci Technol.* [accessed 2019 July 10];37:3782–3793. <https://doi.org/10.1021/es030339w>
- Roy S, Heidel K, Creager C, Chung CF, Grieb T. 2006. Conceptual model for organic carbon in the Central Valley and Sacramento–San Joaquin Delta. Lafayette (CA): Tetra Tech, Inc. Final report. [accessed 2019 July 10]; 147 p. Available from: http://www.swrcb.ca.gov/rwqcb5/water_issues/drinking_water_policy/oc_model_final.pdf
- Rydin E, Welch EB. 1998. Aluminum dose required to inactivate phosphate in lake sediments. *Water Res.* [accessed 2019 July 10];32:2969–2976. [https://doi.org/10.1016/S0043-1354\(98\)00055-4](https://doi.org/10.1016/S0043-1354(98)00055-4)
- Smeltzer E. 1990. A successful alum/aluminate treatment of Lake Morey, Vermont. *Lake Reservoir Manag.* [accessed 2019 July 10];6:9–19. <https://doi.org/10.1080/07438149009354691>
- Stumpner EB, Kraus TEC, Liang YL, Bachand SM, Horwath WR, Bachand PAM. 2018. Sediment accretion and carbon storage in constructed wetlands receiving water treated with metal-based coagulants. *Ecol Eng.* [accessed 2019 July 10];111:176–185. <https://doi.org/10.1016/j.ecoleng.2017.10.016>
- Stumpner EB, Kraus TEC, Fleck JA, Hansen AM, Bachand SM, Horwath WR, DeWild JF, Krabbenhoft DP, Bachand PAM. 2015. Mercury, monomethyl mercury, and dissolved organic carbon concentrations in surface water entering and exiting constructed wetlands treated with metal-based coagulants, Twitchell Island, California. Reston (VA): U.S. Department of the Interior, U.S. Geological Survey. Data Series 950. [accessed 2019 July 10];26 p. Available from: <https://pubs.usgs.gov/ds/0950/ds950.pdf>
- Trejo–Gaytan J, Bachand PAM, Darby J. 2006. Treatment of urban runoff at Lake Tahoe: low-intensity chemical dosing. *Water Environ Res.* [accessed 2019 July 10];78:2487–2500. <https://doi.org/10.2175/106143006X102042>
- [USEPA] U.S. Environmental Protection Agency. 2000. Constructed wetlands treatment of municipal wastewaters. U.S. EPA Office of Research and Development; Cincinnati (OH): USEPA. EPA/625/R-99/010 (NTIS PB2001-101833). [accessed 2019 July 10];152 p. Available from: https://cfpub.epa.gov/si/si_public_record_report.cfm?Lab=NRMRL&dirEntryId=64144
- Volk C, Bell K, Ibrahim E, Verges D, Amy G, LeChevallier M. 2000. Impact of enhanced and optimized coagulation on removal of organic matter and its biodegradable fraction in drinking water. *Water Res.* [accessed 2019 July 10];34:3247–3257. [https://doi.org/10.1016/S0043-1354\(00\)00033-6](https://doi.org/10.1016/S0043-1354(00)00033-6)
- Welch EB, Cooke GD. 1999. Effectiveness and longevity of phosphorus inactivation with alum. *Lake Reservoir Manag.* [accessed 2019 July 10];15:5–27. <https://doi.org/10.1080/07438149909353948>

- Welch EB, Schriever GD. 1994. Alum treatment effectiveness and longevity in shallow lakes. In: Mortensen E, Jeppesen E, Søndergaard M, Nielsen LK, editors. 1994. Nutrient dynamics and biological structure in shallow freshwater and brackish lakes. *Developments in hydrobiology*. Vol. 94. Dordrecht (Netherlands): Springer. [accessed 2019 July 10];275/276:423–431. Available from: https://link.springer.com/chapter/10.1007/978-94-017-2460-9_37
- Wilde FD, Radtke DB, Gibs J, Iwatsubo RT, editors. 2004–2009. Processing of water samples. Version 2.2. U.S. Geological Survey Techniques of Water-Resources Investigations, book 9, chapter A5. [accessed 2019 July 10];166 p. Available from: <http://pubs.water.usgs.gov/twri9A5/>

NOTES

- Bachand SM, Merrill A, Deverel SJ, Bachand PAM. Forthcoming. Subsidence and levee failure in the California Delta: the potential for rice to reduce levee failure rates.
- Leggiere TC. 2004. Advanced treatment systems overview. Clearwater Compliance Services. Presented at CalEPA Conference on Advanced Treatment for Construction Sites; October 21, 2004; Sacramento, CA. Available from: https://www.waterboards.ca.gov/water_issues/programs/stormwater/docs/advtrat/clearwatercompliance.pdf
- Macpherson J. 2004. Storm-Klear (chitosan) toxicity and applications, construction stormwater treatment. Natural site solutions. Presented at the Conference on Advanced Treatment for Construction Sites, Sacramento, CA; October 21, 2004. Available from: https://www.waterboards.ca.gov/water_issues/programs/stormwater/docs/advtrat/naturalsitesolutions.pdf