

KILNS AND FIRING STRUCTURES

الأفران

Paul T. Nicholson

EDITORS

WILLEKE WENDRICH
Editor-in-Chief
Area Editor Material Culture
University of California, Los Angeles

JACCO DIELEMAN
Editor
University of California, Los Angeles

ELIZABETH FROOD
Editor
University of Oxford

JOHN BAINES
Senior Editorial Consultant
University of Oxford

Short Citation:
Nicholson 2010, Kilns and Firing Structures. *UEE*.

Full Citation:
Nicholson, Paul T., 2010, Kilns and Firing Structures. In Willeke Wendrich (ed.), *UCLA Encyclopedia of Egyptology*, Los Angeles. <http://digital2.library.ucla.edu/viewItem.do?ark=21198/zz0025sr24>

KILNS AND FIRING STRUCTURES

الأفران

Paul T. Nicholson

Brennöfen und Schmelzöfen (ausser Metallverarbeitung)

Fours et structures de cuisson (céramique, faïence, verre)

The purpose of firing pottery is to change clay, a plastic material, into ceramic, which is aplastic. Examined here are structures designed to fire pottery or faïence or to make glass (although the latter might be better described as furnaces). Firing can take place in an open, bonfire-like environment, which can also be enclosed as a firing structure. Beyond this is the development of the true kiln of which there are two main types: updraft and downdraft. The first of these is by far the most common on archaeological sites throughout the world dating to before the nineteenth century CE. Here the firing technology of ancient Egypt is discussed in particular.

الغرض من حرق الفخار هو تحويل الطين من مادة مرنة إلى فخار أي مادة صلبة. تتناول هذه المقالة الأفران المخصصة لحرق الفخار أو الفايينس أو لصناعة الزجاج. يمكن أن يتم الحرق بمكان مكشوف ويمكن أيضاً أن يكون المكان مغلقاً. يوجد نوعان من الأفران: نوع يعمل بالتيار الهوائي من أسفل إلى أعلى والآخر يعمل بالتيار الهوائي من أعلى إلى أسفل. النوع الأول هو الأكثر شيوعاً بالمواقع الأثرية بالعالم كله ويعود إلى ما قبل القرن التاسع عشر. تتناول هذه المقالة تقنيات الحرق بمصر القديمة.

Pottery is fired in order to effect the change from clay, a plastic material, into aplastic ceramic (see Rice 1987: 102 - 110). This is done by first evaporating the water that lubricates the clay platelets and renders the clay malleable, then driving off the water that is chemically combined in the clay mineral structure. The clay platelets subsequently begin to fuse together at their edges in a process known as “sintering.” This is the first stage in vitrification and varies according to the clay type but usually begins between 600°C and 700°C. If continued to higher temperatures the clay would eventually become fully vitrified and collapse after becoming essentially molten. Firing aims to sinter the material to a point below complete vitrification, so rendering the clay ceramic.

The history of the kiln is a history of improvements or changes to the way that pottery is fired and encompasses arrangements that would not strictly qualify as “kilns.” Holthoer (1977: 34 - 35) has attempted to provide a fourfold classification of kilns, but this has not gained wide acceptance and is inconsistently applied in his examples. A simpler classification has been proposed (Nicholson 1993: 108), making three broad distinctions: 1) open firing; 2) firing structures; and 3) updraft kilns. The latter might be further subdivided as suggested by Arnold (1976, 1986). A fourth type, the downdraft kiln, is not encountered in Pharaonic Egypt.

Open Firing

Among the methods that do not employ a fixed kiln structure is the so-called “open firing,” sometimes referred to as “bonfire firing,” although this latter term implies a rather less orderly arrangement than is usually the case. In open firing the fuel is stacked over (and sometimes among) the vessels (see Hodges 1981: 35 - 41). Maximum temperatures reached in an open fire are comparable to those of an unroofed updraft kiln and quite sophisticated results can be obtained. Temperatures of up to c. 1000°C can be reached—the upper range of the firing of pottery referred to as “terracotta” (Rice 1987: 82). By its nature an open firing leaves little or no detectable archaeological trace, and any remains that do survive could be mistaken for a large domestic hearth. Indeed, small quantities of pottery may have been fired at the domestic hearth, and it should be remembered that many clays will begin to vitrify at temperatures between 600°C and 800°C.

Open firing may suffer from lack of control of the firing and from the smudging of the vessels from contact with the fuel; it is furthermore susceptible to sudden changes in weather conditions. Over wide areas of the world this latter problem was countered by firing in trenches, as did the Hopi of North America, or by adding a small wall around the base of the fuel heap, as was done in parts of India. These strategies might be regarded as the simplest kinds of firing structure.

Firing Structures

The arrangement described by Harlan (1982) and Hoffman (1982: 7 - 14) at Hierakonpolis, locality 11C, may represent a development from simple open firing. Dated c. 3200 - 3100 BCE, the structure is a pit in the ground that seems to have contained fuel, while the vessels to be fired stood on “dog-biscuit shaped blocks,” 150 – 250 mm high. The excavators describe this as a simple updraft kiln, because the vessels were raised from the fire on the “dog biscuit” blocks. Although

technically correct in that the draft (hot gases) moved upward, it is preferable to regard such arrangements as firing structures to avoid confusion with true updraft kilns.

A further development, and one providing greater protection to the vessels than the arrangement from Hierakonpolis, is the structure known, rather misleadingly, as the “box oven,” a step between open firing and the true updraft kiln. The box oven is essentially a containing wall within which pots are stacked. The fire may be within the wall or, as in the Amarna example described below, outside it and drawn in through an opening at the bottom of the wall. In a true updraft kiln, on the other hand, the fire is located beneath the stack of vessels and is separated from them by a perforated floor (Nicholson 1989). Box ovens are known from at least as early as the Middle Kingdom, at sites such as Mirgissa, and from the New Kingdom at el-Amarna, where an example has been excavated containing its charge of vessels (fig. 1; Kemp 1987: 73 - 76). Holthoer (1977: 16) regarded the Mirgissa structure as a bread oven, and it is indeed possible that the same structure served the dual function of breadmold-firing and subsequent bread-baking. It has been shown experimentally that the Amarna kiln/oven could have been used to fire the vessels found within it (fig. 2; Nicholson 1989), and this would certainly have been a more fuel-efficient way of firing the pots than open firing.

Updraft Kilns for Pottery, Faience, and Glass

“True” kilns can be divided into two main types, updraft and downdraft, the distinction between them being whether the hot gases pass upward or downward through the stack of vessels being fired (Hodges 1981). The updraft kiln is by far the most common historically. In this type of kiln (fig. 3) the fire is in the lowermost part of the kiln, known as the fire box or fire pit, and is separated from the vessel stack by a perforated floor or “chequer,” through which the hot gases travel up into the firing chamber where the vessels are stacked. Vessels are commonly inverted in



Figure 1. Box oven excavated at Chapel 556 of the workmen's village at el-Amarna.



Figure 2. Experimental firing of reconstruction of box oven found at Chapel 556 of the workmen's village, el-Amarna. Note that the fire is outside the structure, which draws in the flame to fire the vessels.

the stack so that each becomes filled with the hot gases, thereby slowing the upward passage of the gases through the structure (fig. 4; Nicholson and Patterson 1989). This has the effect of increasing the efficiency of the firing, consuming less fuel to achieve the desired result. This is particularly important since it is

common for Egyptian updraft kilns to be open at the top, rather than enclosed by a dome. Vessels stacked in such open-topped structures, at least as observed in modern Egypt, are usually given a covering of sherds (figs. 5 and 6). The sherd layer acts as a collecting point for soot from the firing, so that the vessels themselves are not blackened by the fuel. It also serves to give a minimal amount of insulation to the stack. The last phase of a firing is often to throw dry vegetation onto the covering of sherds, where it ignites and removes much of the buildup of carbon.

The expansion of vessels tightly packed in a kiln puts considerable stress on the kiln walls, which are usually made of mud-brick that becomes fired brick in situ over time. It is likely that the walls were reinforced in some way, probably by tying large ropes around them in order to prolong their lives (fig. 7). Several tomb scenes show kilns with what appear to be reinforcement bindings around them. This practice of binding the kiln, albeit with iron chains, wire belts, or metal bands rather than ropes, remained common in the European pottery industry into the twentieth century. Such features are clearly demonstrated on the so called "bottle kilns" at Stoke-on-Trent, United Kingdom.

It is these updraft kilns that are commonly depicted in tomb scenes, particularly from the Middle and New Kingdoms (conveniently summarized by Holthoer 1977: fig. 50) although Old Kingdom examples are known, such as those in the tomb of Ty at Saqqara (Épron et al. 1939: pl. 71). Due to the conventions of Egyptian art, it is difficult to determine the scale of these structures, but it is evident from scenes depicting them being unloaded (for example, those at Beni Hasan) that they stood taller than a man and sometimes needed a step or bench at the bottom in order that they could be reached into. Determining the diameter of such structures is more difficult, and there are no known scenes showing a kiln being loaded or unloaded from the inside, as is often the case with present-day Egyptian kilns (see

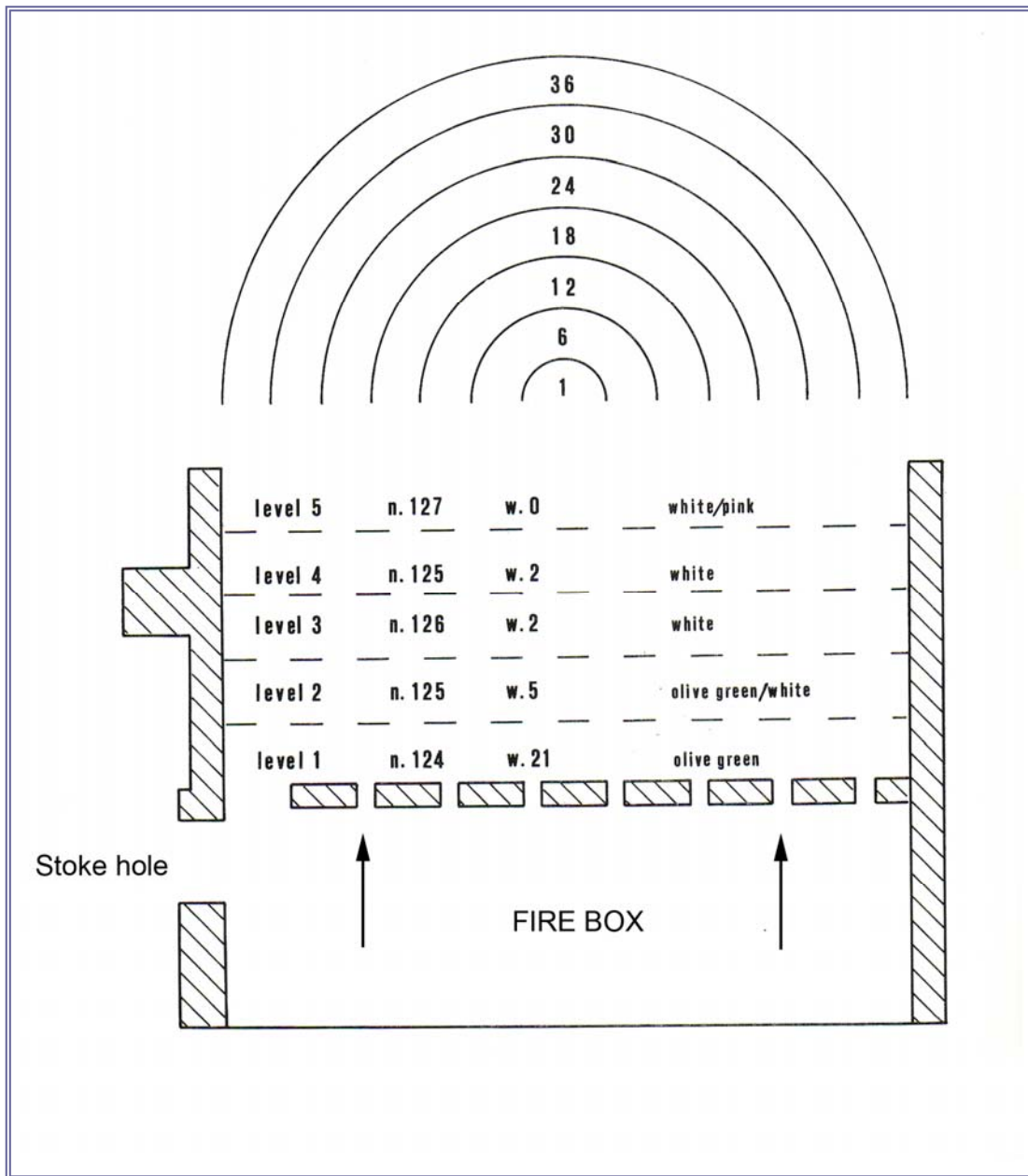

Figure 3. Section drawing of updraft kiln at Deir el-Gharbi, Upper Egypt. Fire box is beneath a perforated floor through which the heat passes (see arrows). Above floor are stacked rows of vessels. The letter “n” = number of vessels per row; “w” = number of vessels wasted in firing. Vessel color changes according to position in kiln.

Nicholson 1995b; Nicholson and Patterson 1989).

Fortunately, we are not solely dependent upon depictions of pottery kilns: there are numerous extant examples from Egypt from several periods, including the Old Kingdom at Elephantine (Kaiser et al. 1982) and the First

Intermediate Period at Ayn Asil (Balat) (Soukiasian et al. 1990). The excavation at the latter site gives a good impression of the spatial organization of a First Intermediate Period workshop, including tall, tower-like kilns quite wide enough to have accommodated a person during stacking and



Figure 4. Stacking vessels into a kiln at Deir el-Gharbi. Note that the vessels are inverted so as to contain the hot gases passing up through the perforated floor.

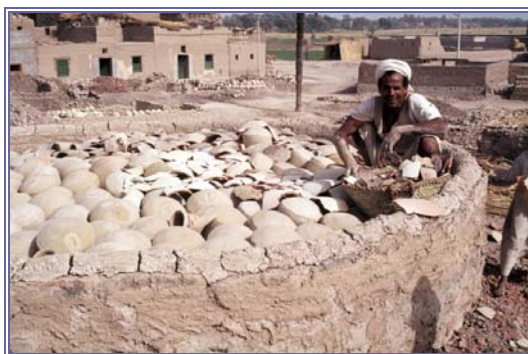

Figure 5. Covering the open top of a kiln at Deir el-Gharbi with sherds. These provide a degree of insulation and also serve to collect soot so that the finished vessels are not blackened.

unloading. The excavators grouped the kilns into several types, largely depending on how the perforated floor, or chequer, was supported. In types 1 through 3 the chequer rested on walls or pillars, while in types 4 and 5 it was supported on projections around the wall, rather than extending onto a support at or near the center of the structure.

All the contemporary Egyptian pottery kilns with which the writer is familiar have the perforated floor springing as a low vault from ground-level projections around the side, as seen in Balat types 4 and 5, or from projections higher up the walls. This arrangement leaves the fire box free of obstruction and makes fueling and raking easier. It is the arrangement that appears to have been used in the several known New Kingdom kilns from el-Amarna. The first of



Figure 6. A firing at Deir el-Gharbi. The kiln is covered only by a layer of sherds and has no afixed dome. Note that the structure is built into a mound for insulation.

these was discovered by Borchardt (1933), who believed it to be a bread oven. This structure, in house P47.20, was re-excavated in the 1990s (Nicholson 1995a) and found to be a pottery kiln similar to several others at the site.

Archaeologically, kilns may show evidence of vitrification, since the mud-brick with which they are constructed—often of the same Nile clay as the pots themselves—is fired over and over again. This vitrification is commonly referred to as “slag” by archaeologists as a convenient shorthand, a term that sometimes leads to the belief that the kilns were actually employed for metallurgy (or less correctly glass production, since slag is specific to metallurgy). In fact the substance in question is not true slag (see Bachmann 1982) and is not encountered in all kilns. Because much Pharaonic pottery is fired



Figure 7. An experimental pottery kiln built at el-Amarna and reinforced with rope bindings to help counter the expansion caused by the pottery charge.

at temperatures of 800°C or less it is quite common for the walls of kilns simply to be reddened rather than vitrified. By the same token kiln sites should not be expected to feature “wasters” (overfired vessels): underfiring was almost certainly a more common fault than overfiring.

One of the reasons for the buildup of so-called slag can be the reaction between the “fly ash” (literally, particles of ash moved up through the structure by the hot gases) and the kiln wall. The silica from ash, along with alkalis contained in it, act to make up the siliceous slag, essentially a layer of glass or glaze on the kiln wall. Fly ash is undesirable, particularly during the firing of vessels with a decorated surface or of glazed wares (such glazed pottery is known in Egypt from Roman times onward).

One way of obviating the problem of fly ash is to use a downdraft kiln. These were not common in antiquity, however, and the difficulty was more usually solved by the use of “saggars.” Saggars were ceramic containers, stacked one on top of the other, in which pottery whose surface might be damaged by fly ash, or blackened by soot from smoke, was fired. In essence each saggars acted as a miniature, closed kiln (see Brown 1976: 86 - 87). An alternative was to channel the hot gases through vertical pipes between which the vessels were stacked. This arrangement is known from Europe during the Roman Period, and although not yet known from Egypt, it would not be surprising to find it there (Brown 1976: 84 - 85).

It is worth repeating here that the top temperature for an uncovered updraft kiln is c. 1000°C. The addition of a dome, which serves to reflect heat back into the structure as well as to contain it, can yield temperatures of 1150°C. Beyond this the Nile silt clay rapidly vitrifies and begins to collapse. Mud-bricks and pottery are essentially of the same material and are thus subject to the same considerations when heated. Where kilns show evidence for a dome, one should consider the possibility that they were glass or metal furnaces rather than pottery kilns, although domed pottery kilns are documented from the ancient world. It has been suggested from the raw materials found in their association that the large kilns or furnaces discovered at el-Amarna, and which show signs of a dome, were intended for the making of glass.

Downdraft Kilns

The downdraft kiln is not known from Pharaonic Egypt and is mentioned here only in passing. In this type of kiln the hot gases usually pass over a baffle wall of some kind before being drawn down through the stack of vessels and leaving the kiln via a chimney at the rear of the structure, the chimney acting as the means by which the gases are drawn (see Hodges 1981: 35 - 41). The firing chamber of such a kiln is enclosed—usually by a dome.



Figure 8. Firing of reconstruction of the glass furnace found at el-Amarna site O45.1. The domed superstructure helps to retain and reflect heat.

The advantage of such a structure is that the heat remains within the kiln longer and there is less chance of discoloration of the vessels as a result of smoke or ash. The downdraft kiln is also capable of reaching temperatures of up to c. 1300°C, whereas the maximum for an uncovered updraft kiln is c. 1000°C. If a dome is added to an updraft kiln, then temperatures of up to c. 1150°C may be achieved, since the dome helps to retain heat as well as reflect it downwards.

Faience Kilns

Faience kilns are sometimes referred to as furnaces by archaeologists, because it is assumed that they operated at very high temperatures, and also perhaps because in Roman times they could be very large. In fact the temperatures necessary for firing faience were usually well within the temperature range of terracotta firing (maximum 1000°C).

Pharaonic faience was fired in numerous ways—many of them akin to the methods used to produce pottery. At Abydos, for example, there is evidence for the open firing of faience during the Old Kingdom and First Intermediate Period, as well as for a possible kiln or firing structure (see Nicholson and Peltenburg 2000: 180 - 181). There is also a possible kiln from Lisht, where a faience-making area was identified.

Much more evidence for faience production is available for the New Kingdom, not least

from el-Amarna (Petrie 1894); however, there is some uncertainty about the kilns themselves. Nicholson (2007) has identified possible faience kilns at el-Amarna site O45.1, but these are of the same design as pottery kilns and their attribution to faience remains tentative. Since they occur at a locality where faience as well as pottery is known to have been made, and since both faience and pottery kilns would have operated within the same temperature ranges, they cannot definitely be ascribed to the faience-making operation. It would not be surprising to find that pottery and faience were sometimes fired in the same kilns, albeit not at the same time, since different temperatures might have been required and/or because saggars might have been needed for the faience. The excavators at el-Amarna also found large updraft kilns at O45.1, which they believe were used for firing glass (fig. 8). These structures, too, could have served for faience production, fired to a lower temperature than that required for the reacting together and subsequent melting of glass.

At least some of the faience may well have been fired in saggars (see above) during the New Kingdom and later, and these are very well attested from the Roman Period at the site of Kom Helul, Memphis (Petrie 1909, 1911). Here Petrie recorded very substantial rectangular kilns, sunk up to c. 5 m into the ground. These are currently being reinvestigated.

Lime Kilns

Kilns for the reduction of limestone to lime for use either as mortar or for agriculture are not securely attested from Pharaonic Egypt. James Harrell (personal communication: January 2010) notes that the use of lime plaster is not certainly recorded before the Ptolemaic era; consequently the occurrence of lime kilns cannot be expected before that date. Lime kilns differ from kilns for firing pottery or faience in that they did not bind material together, but rather reduced it to a friable state. Henein (2002), however, records the use of a combined pottery and lime kiln in

Dakhla Oasis, though this appears to be a very localized practice introduced in Islamic times and requiring further study. Because of

their specialized nature, lime kilns do not normally feature in accounts of kiln technology.

Bibliographic Notes

Publications dealing specifically with Egyptian kilns are few, and the literature scattered. Although dated and generalized in its approach, Henry Hodges' classic work, *Artifacts* (1981), remains a valuable starting point for understanding the topic, while Rice (1987) gives a good overview of kilns and their use in ceramic manufacture. Nicholson (1993) summarizes what was known of Egyptian pottery kilns up to that date and draws on pioneering work by Arnold (1976, 1986). The publication of recent work at el-Amarna (Nicholson 2007) covers the construction of pottery, faience, and glass kilns/furnaces at that site. The Roman faience furnaces at Kom Helul, Memphis, are currently being re-investigated, but Petrie's publications (1909, 1911) give some indication of their scale. Work on kilns and furnaces in Egypt is still relatively rare; much remains to be done.

References

Arnold, Dorothea

1976 Wandbild und Scherbenbefund: Zur Töpfertechnik der alten Ägypter vom Beginn der pharaonischen Zeit bis zu den Hyksos. *Mitteilungen des Deutschen Archäologischen Instituts, Abteilung Kairo* 32, pp. 1 - 34.

1986 Töpferei. In *Lexikon der Ägyptologie*, Vol. 6 (columns 616 - 621), ed. Wolfgang Helck, and Wolfhart Westendorf. Wiesbaden: Otto Harrassowitz.

Bachmann, Hans-Gert

1982 *The identification of slags from archaeological sites*. Occasional Publication 6. London: Institute of Archaeology.

Borchardt, Ludwig

1933 Ein Brot. *Zeitschrift für Ägyptische Sprache und Altertumskunde* 60, pp. 73 - 79.

Brown, David

1976 Pottery. In *Roman crafts*, ed. Donald Strong, and David Brown, pp. 74 - 91. London: Duckworth.

Épron, Lucienne, François Daumas, Jean-Claude Goyon, and Pierre Montet

1939 *Le tombeau de Ti: Part I*. Mémoires publiés par les membres de l'Institut français d'archéologie orientale 65. Cairo: Institut français d'archéologie orientale.

Harlan, J. Fred

1982 Excavations at locality 11C. In *The predynastic of Hierakonpolis: An interim report*, Egyptian Studies Association Publication 1, ed. Michael Hoffman, pp. 14 - 25. Cairo: Cairo University; Macomb, Ill.: Western Illinois University.

Henein, Nessim Henry

2002 The potters of Dakhla Oasis and their kilns. In *Moving Matters: Ethnoarchaeology in the Near East: Proceedings of the International Seminar held at Cairo 7 - 10 December 1998*, CNWS Publications 111, ed. Willeke Wendrich, and Gerrit van der Kooij, pp. 93 - 102. Leiden: Research School of Asian, African, and Amerindian Studies, Leiden University.

Hodges, Henry

1981 *Artifacts: An introduction to early materials and technology*. London: Baker. (Corrected reprint.)

- Hoffman, Michael (ed.)
1982 *The predynastic of Hierakonpolis: An interim report*. Egyptian Studies Association Publication 1. Cairo: Cairo University; Macomb, Ill.: Western Illinois University.
- Holthoer, Rostislav
1977 *New Kingdom Pharaonic sites: The pottery*. Scandinavian Joint Expedition to Sudanese Nubia 5:1. Lund: Scandinavian University Books.
- Kaiser, Werner, Robert Avila, Günter Dreyer, Horst Jaritz, Friedrich Rösing, and Stephan Seidlmayer
1982 Stadt und Tempel von Elephantine: Neunter/Zehnter Grabungsbericht. *Mitteilungen des Deutschen Archäologischen Instituts, Abteilung Kairo* 38, pp. 271 - 344.
- Kemp, Barry
1987 Report on the 1986 excavations: Chapel 556. In *Amarna reports*, Occasional Publications 4, ed. Barry Kemp, pp. 70 - 86. London: Egypt Exploration Society.
- Nicholson, Paul T.
1989 Experimental determination of the purpose of a "box oven". In *Amarna reports*, Occasional Publications 5, ed. Barry Kemp, pp. 241 - 252. London: Egypt Exploration Society.
1993 The firing of pottery. In *An introduction to ancient Egyptian pottery*, ed. Dorothea Arnold, and Janine Bourriau, pp. 103 - 120. Mainz am Rhein: Philipp von Zabern.
1995a Kiln excavations at P47.20 (house of Ramose complex). In *Amarna reports*, Occasional Publications 6, ed. Barry Kemp, pp. 226 - 238. London: Egypt Exploration Society.
1995b The potters of Deir Mawas: An ethnoarchaeological study. In *Amarna reports*, Occasional Publications 6, ed. Barry Kemp, pp. 279 - 308. London: Egypt Exploration Society.
2007 *Brilliant things for Akhenaten: The production of glass, vitreous materials and pottery at Amarna Site 045.1*. Egypt Exploration Society Excavation Memoir 80. London: Egypt Exploration Society; Oakville, CT: David Brown Book Co.
- Nicholson, Paul T., and Helen L. Patterson
1989 Ceramic technology in Upper Egypt: A study of pottery firing. *World Archaeology* 21(1), pp. 71 - 86.
- Nicholson, Paul T., and Edgar Peltenburg
2000 Egyptian faience. In *Ancient Egyptian materials and technology*, ed. Paul T. Nicholson, and Ian Shaw, pp. 177 - 194. Cambridge: Cambridge University Press.
- Petrie, William Matthew Flinders
1894 *Tell el-Amarna*. London: Methuen.
1909 *Memphis*. Vol. 1. London: British School of Archaeology in Egypt and Bernard Quaritch.
1911 The pottery kilns at Memphis. In *Historical Studies*, Vol. II, ed. Edward Ball Knobel, William Midgley, Joseph Milne, Margaret Alice Murray, and William Matthew Flinders Petrie, pp. 34 - 37. London: British School of Archaeology in Egypt and Bernard Quaritch.
- Rice, Prudence
1987 *Pottery analysis: A sourcebook*. Chicago: The University of Chicago Press.
- Soukiassian, Georges, Michel Wuttmann, Laure Pantalacci, Pascale Ballet, and Maurice Picon
1990 *Balat 3: Les ateliers de potiers d'Ayn-Asil: Fin de l'Ancien Empire, Première Période Intermédiaire*. Fouilles de l'Institut français d'archéologie orientale 34. Cairo: Institut français d'archéologie orientale.

Image Credits

- Figure 1. Box oven excavated at Chapel 556 of the workmen's village at el-Amarna. Photograph by the author. Courtesy of the Egypt Exploration Society.
- Figure 2. Experimental firing of reconstruction of box oven found at Chapel 556 of the workmen's village, el-Amarna. Note that the fire is outside the structure, which draws in the flame to fire the vessels. Courtesy of the Egypt Exploration Society.

- Figure 3. Section drawing of updraft kiln at Deir el-Gharbi, Upper Egypt. Fire box is beneath a perforated floor through which the heat passes (see arrows). Above floor are stacked rows of vessels. The letter “n” = number of vessels per row; “w” = number of vessels wasted in firing. Vessel color changes according to position in kiln. Drawing by Helen L. Patterson.
- Figure 4. Stacking vessels into a kiln at Deir el-Gharbi. Note that the vessels are inverted so as to contain the hot gases passing up through the perforated floor. Photograph by the author.
- Figure 5. Covering the open top of a kiln at Deir el-Gharbi with sherds. These provide a degree of insulation and also serve to collect soot so that the finished vessels are not blackened. Photograph by the author.
- Figure 6. A firing at Deir el-Gharbi. The kiln is covered only by a layer of sherds and has no afixed dome. Note that the structure is built into a mound for insulation. Photograph by the author.
- Figure 7. An experimental pottery kiln built at el-Amarna and reinforced with rope bindings to help counter the expansion caused by the pottery charge. Photograph by the author. Courtesy of the Egypt Exploration Society.
- Figure 8. Firing of reconstruction of the glass furnace found at el-Amarna site O45.1. The domed superstructure helps to retain and reflect heat. Photograph by the author. Courtesy of the Egypt Exploration Society.