

# Urban Journeys of the Rhizomatic Line

**Mohammad Moezzi**

## **Abstract**

This paper disrupts the conventional visual hierarchy inherent in architectural photography and imaging by introducing the "rhizomatic line." Architectural drawing is a constructive metaphor that fuses imagination, speculation, desire, memory, and dream. Instead of conventional triadic categorizations, such as foreground, middle ground, and background, or *poché*, *entourage*, and *mosaïque*, this hand drawing method reconnects spatial observations. Inspired by the philosophical concept of the rhizome by Gilles Deleuze and Felix Guattari, the rhizomatic line generates a drawing that invites the creator and observer to explore spaces in a more enactive and integrated manner. The paper showcases the potential of this method through four rhizomatic lines drawn by the author as examples, offering a phenomenological understanding of spatial lived experiences that transcends Cartesian fragmented visual hierarchies.

**Keywords:** architectural drawing, rhizomatic line, non-hierarchical representation, spatial hand drawing.

## Introduction

Using visual hierarchy, representational media often separate diverse urban experiences. Three categories of foreground, middle ground, and background are easily distinguished in photography and painting. Urban sketches separate buildings, figures, and natural features. In architectural working drawing, “poché, entourage, and mosaïque” forms a structural system for representing cut walls, environment, and texture respectively. (Young, p. 10) Recently, photogrammetry or Lidar scanning claim to break these hierarchies by creating “a uniform unbiased document of things in space as they exist.” (Young, p. 53) However, these tools fail to reveal the speculative imaginary experiences hidden behind surfaces.

This series of my hand drawings that I named “rhizomatic line”, is the result of a non-hierarchical process inspired by French philosophers Gilles Deleuze and Felix Guattari's concept of rhizomes. Described as an array of attractions without beginning or end, a rhizome negotiates between things, “fosters connections between fields, the removal of blockages.”(Deleuze & Guattari, p. 12) Rather than producing fragmented abstract shapes, the rhizomatic line moves between the objects and intertwines them. Seemingly recording eye movement, rhizomatic line does not construct complete outlines, but through loosing their completion, it connects them. As it explores the city, it does not differentiate between humans, pedestrian lines, high-rise building edges, urban skylines, stairways, leaves of a small plant hiding behind a window in a private room, entrances to residential units atop towers, or imaginative spaces.

When looking at similar images, different people show different eye movements. (Yarbus) A designer sees the world in the process of construction, and from multiple perspectives at once. Architects use a specific language to draw rhizomatic lines. Particularly, axonometric projection takes advantage of both the visual aspect of perspective in photography, as well as the mathematical precision of orthographic projection in computer cartesian systems. Although I do not claim that my rhizomatic lines are true or close to the vision, I emphasize on “a

continuous space in which elements are in constant motion." (Allen, p. 19) The dotted texture suggests one understanding of the scene's porosity, among many others. Through the blurring of boundaries between poché, entourage, and mosaïque, only a portion of the image is displayed as a work under construction, inviting the viewer to complete it with their imagination. In this sense, a rhizomatic line is not a cartesian representation of space. This single "active line" ending in itself, is an exploratory journey fusing imaginations, speculations, desires, memories, and dreams about the city; "a walk for a walk's sake." (Klee, p. 16.)

### Works Cited

- Allen, Stan. (2009) "Construction with Lines: On Projection", *Practice: Architecture, Technique+ Representation*. (New York: Routledge).
- Deleuze, Gilles and Felix Guattari. (1987) *A Thousand Plateaus: Capitalism and Schizophrenia*. Translated by Brian Massumi, (Minneapolis: University of Minnesota).
- Klee, Paul. (1953) *Pedagogical Sketchbook*. Translated by Sybil Moholy-Nagy, (New York: Praeger Publisher).
- Young, Michael. (2021) *Reality Modeled After Images: Architecture and Aesthetics After the Digital Image*. (New York: Routledge).
- Yarbus, Arbus. (1967) "Eye Movements During Perception of Complex Objects" *Eye Movements and Vision*. (Boston: Springer).

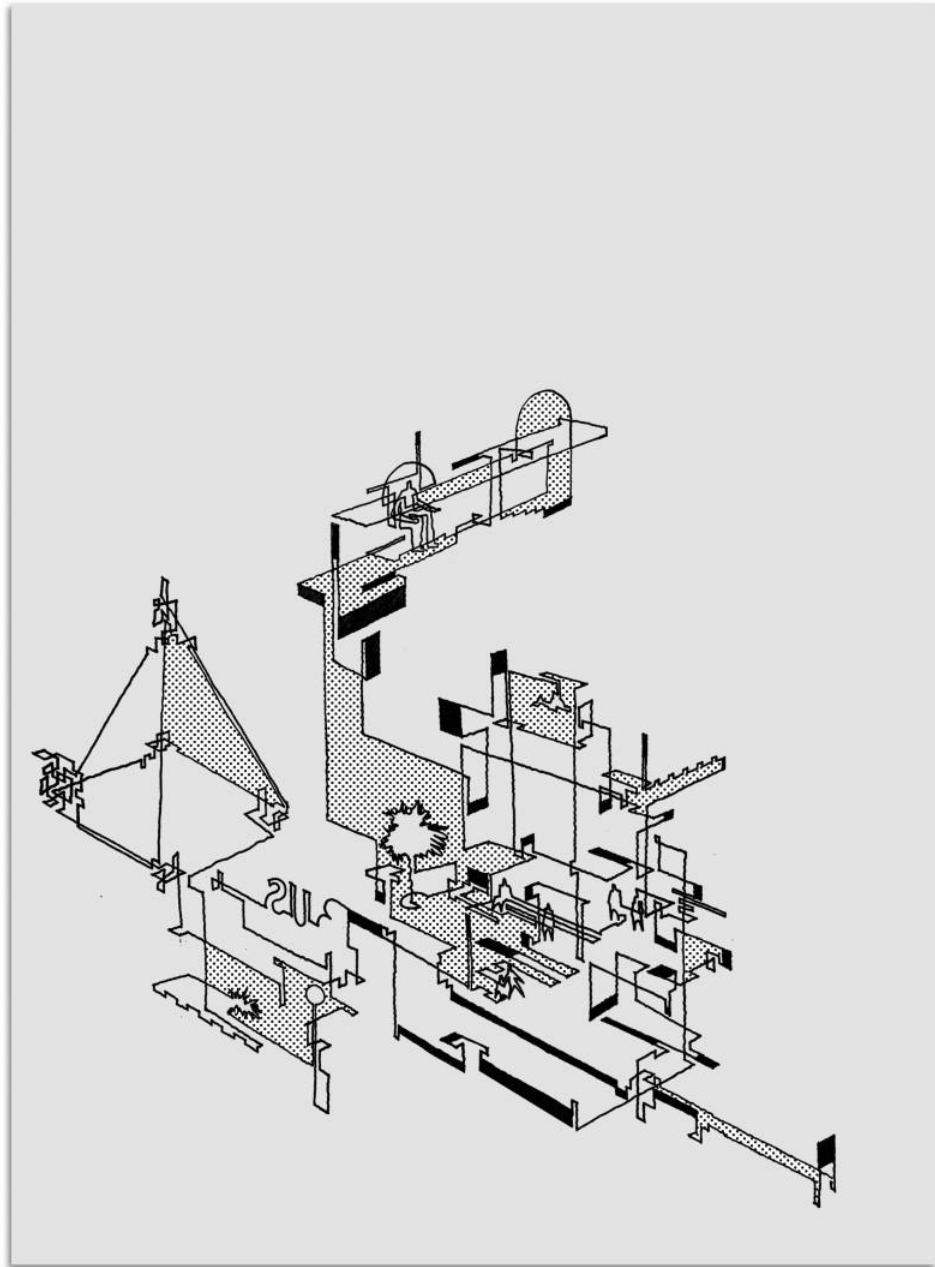

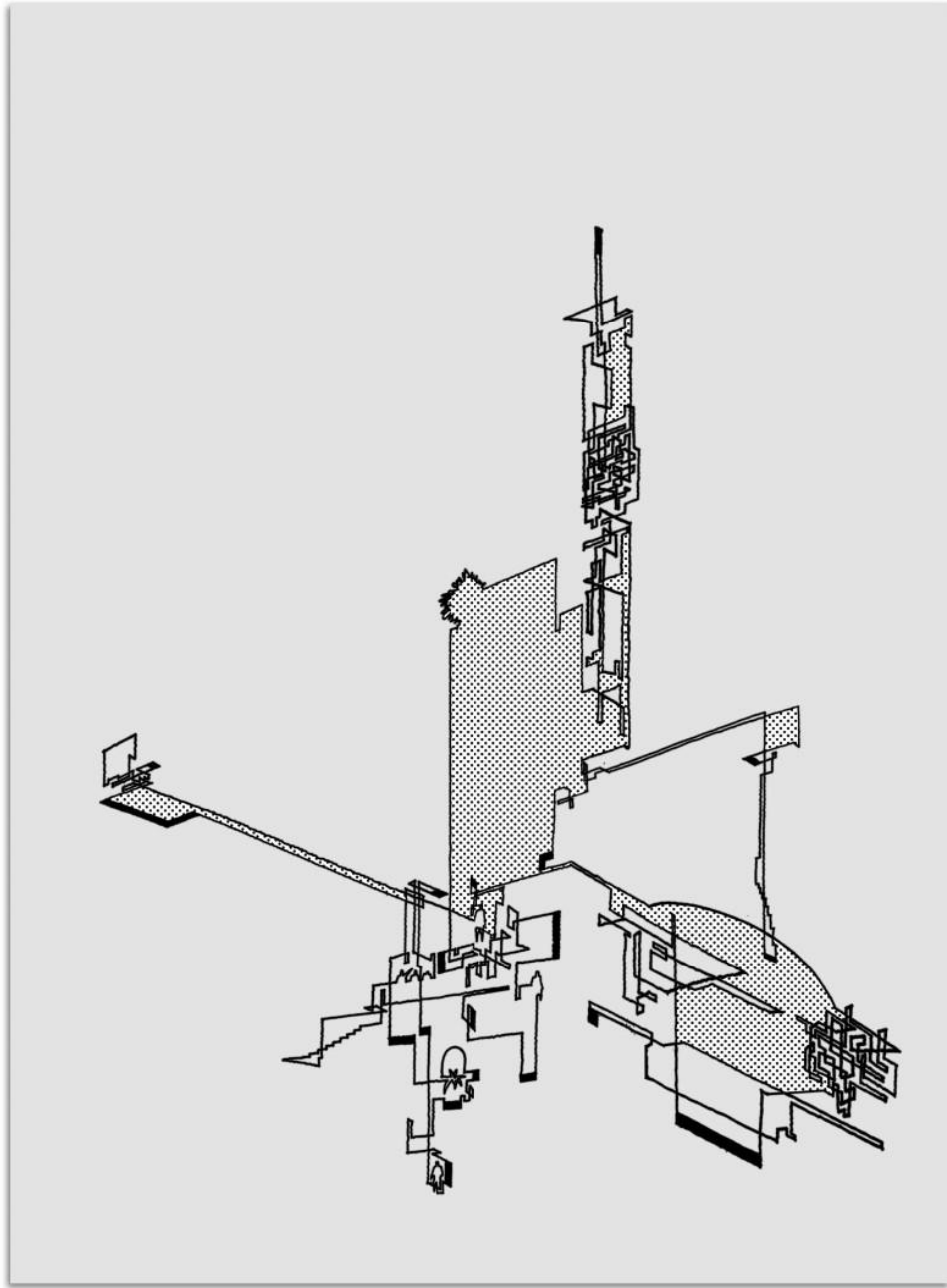

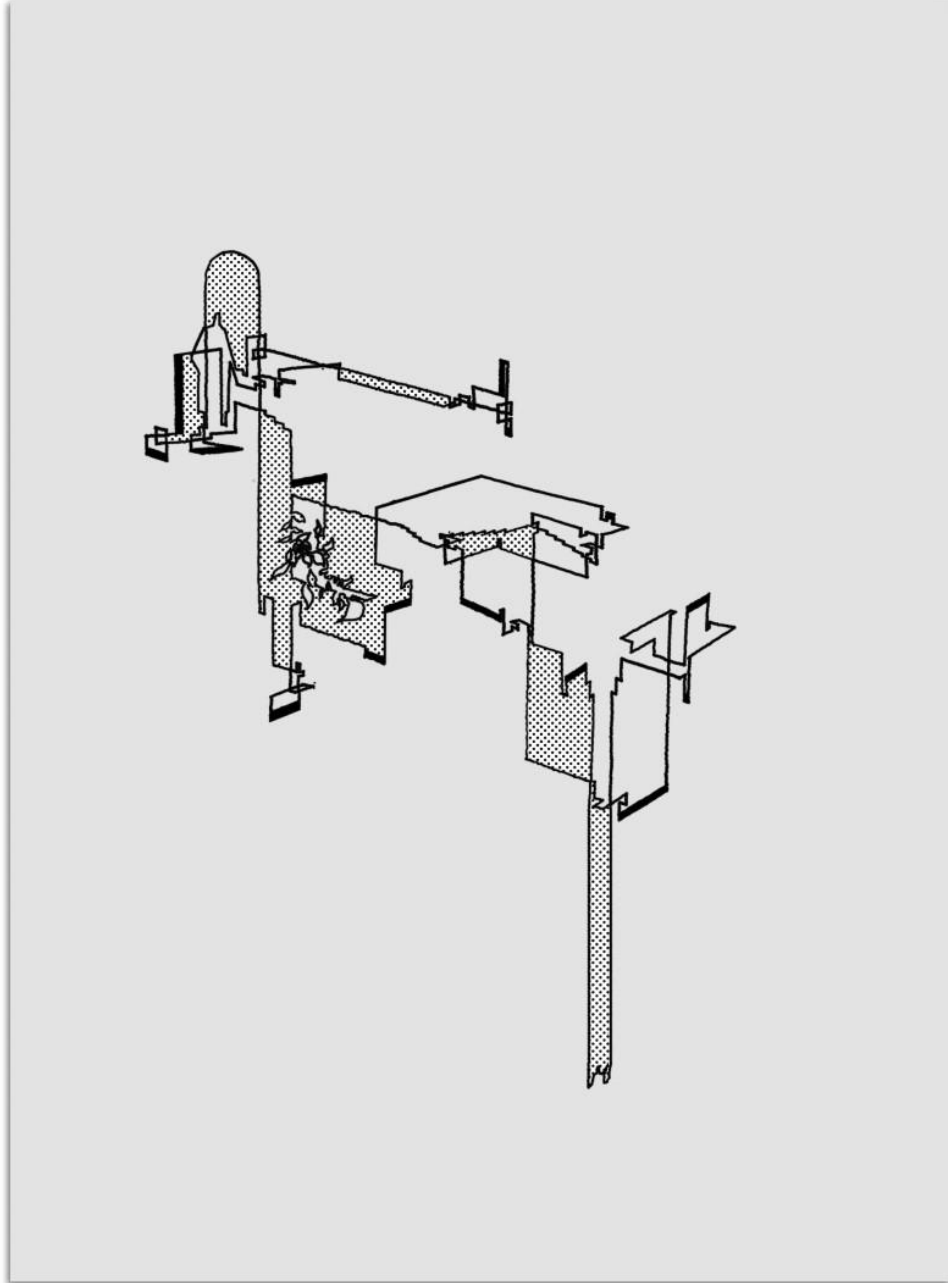

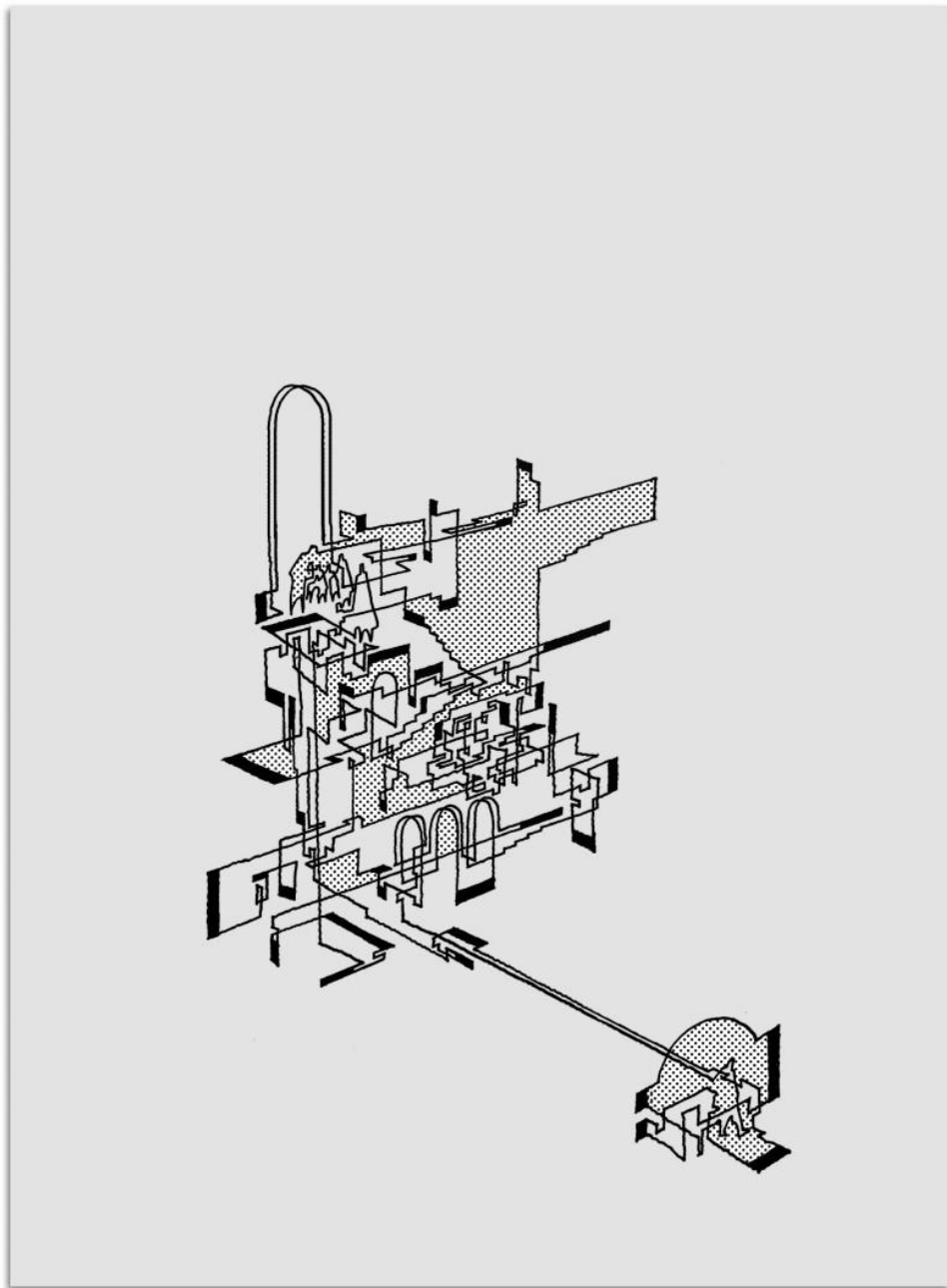

## About the Author

Mohammad Moezzi is an architectural designer, thinker, and educator. His primary research interests lie in the fields of architectural drawing and architectural existential phenomenology. Mohammad received his bachelor's and master's degrees in architecture from Azad University in Iran in 2012 and 2015, respectively. Since graduating, he has gained extensive experience working for several architecture firms, where he has designed a range of residential and public buildings. Over the last decade, Mohammad also dedicated himself to teaching, with a particular focus on architecture foundation courses and drawing theories.

Currently, Mohammad is a PhD candidate at the School of Architecture, Planning, and Landscape (SAPL) at the University of Calgary in Canada. His ongoing PhD research is titled "Dialectical Phenomenology of Architectural Drawing and Digital Image," and is being supervised by Dr Graham Livesey, Dr Paul Emmons, and Dr Marian Macken. His research has received numerous awards, including the Alberta Innovates Technology award in 2022. Mohammad's theoretical drawings have been published and exhibited all around the world, most recently as part of Frascari Symposium VI at the Washington-Alexandria Architecture Centre in the U.S. in 2023:

<https://negarg.wixsite.com/frascarisymposiumvi/copy-of-carolina-dayer-and-jonathan-f>

He has given lectures around the world, including at the National University of Singapore, the University of Toronto, and the Drawing Room in the UK. Mohammad's architectural drawings and related conversations can be found on his social media platforms:

<https://www.instagram.com/m.h.moezzi/>  
<https://www.linkedin.com/in/mohammad-h-moezzi/>